

OPERATORS' GUIDE

LR-CS-82

HYDRAULIC LONG REACH CIRCULAR SAW

For cutting and trimming of limbs and branches from the ground or an aerial bucket that a standard chainsaw could not reach.

The powerful hydraulic drive motor can easily cut brush and branches up to 3.5 inches in a single pass.

The quick stop trigger reduces blade coast time for increased safety.

The dielectric property of the fiberglass extension tube will reduce the chance of electric shock.



WARNING



All information found in this guide must be read and understood before use or testing of this tool.

Failure to read and understand these warnings and safe handling instructions could result in severe personal injury and or death.

CAUTION

Operation and safety methods may vary in accordance with the guidelines established by each utility. For your safety, ensure that you fully comply with all safe operation guidelines established by your respective power utility.

REL-SM

DANGER

The user should be properly trained in the correct procedures required for work on or around electrical lines.

DISTRIBUTED BY



RELIABLE EQUIPMENT & SERVICE CO., INC.

TABLE OF CONTENTS

Registration 2

Saw Description 2-3

Safety Instructions 4-11

SPECIFICATIONS

General 3, 8

Connections and Hoses 9

Pre-Operation 10

Spool Selector (Fig. 1) 10

Operation of Saw 11

MAINTENANCE

General 12

Troubleshooting 13

PARTS LISTS

Major Components (Fig. 2) 14

Head Assembly (Fig.3) 15

Handle (Fig. 4) 16

REPAIR INSTRUCTIONS

Blade & Motor Disassembly 17

Blade Installation 18

Valve/Handle Disassembly 18

Tube Disassembly / Assembly ... 19

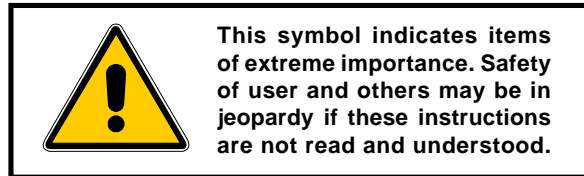

DESCRIPTION

The long reach circular saw is intended for safely cutting and trimming trees which are out of reach of the ordinary chain saw. The powerful hydraulic drive motor can easily make cuts of 3.5 inch depth from the ground or an aerial bucket. With an overall length of 82 inches, the operator is easily able to reach limbs not possible with a standard chain saw.

The dielectric property of the fiberglass extension tube will reduce the chance of electric shock when used near an energized electric line. Other features include a trigger guard to prevent accidental movement of the blade, and a rubber collar hand stop. A quick set spool can be turned 180 degrees for closed center/open center operations.

UPON RECEIPT OF THIS TOOL, COMPLETE THE REGISTRATION BELOW.

SERIAL NUMBER _____

DATE OF PURCHASE _____

DEALER NAME _____



RELIABLE EQUIPMENT & SERVICE CO., INC.

NEW LR-CS-82

HYDRAULIC LONG REACH CIRCULAR SAW

Reliable's LR-Series long reach saws are intended for safely trimming trees from the ground or an aerial bucket. With an overall length of 82 inches, the operator may easily reach areas not possible with a standard chain saw. The offset head provides a flush cut, from a comfortable stance, reducing operator fatigue and strain.

The powerful hydraulic drive motor can easily cut branches up to 3.5 inches in a single pass. The quick stop trigger reduces blade coast time for increased safety. The dielectric property of the fiberglass extension tube will reduce the chance of electric shock.

FEATURES:

Insulated fiberglass extension tube - reduces risk of electrical shock when used near an energized line.

Quick Stop System - reduces blade coast time.

Trigger Guard - prevents accidental blade activation.

Quick Set Spool - may be turned 180° for open center or closed center operation.

9" Blade - Allows a 3.5 inch cutting depth

Rubber Collar Hand Stop.

SPECIFICATIONS:

Weight: 9.3 lbs. **Length:** 82 inches

Flow Range: 5-8 gpm

Blade Speed: 4,800 RPM @ 6 gpm

Operating Pressure: 1,000-2,000 psi

Pressure & Return Port Thread: # 6 SAE & # 8 SAE

Blade Diameter: 9 inches

Blade Thickness: .1/16 inch

Arbor: 0.635" x 0.878 inch

Blade Operating RPM: 5,400 (minimum)



Meets OSHA
1910.269

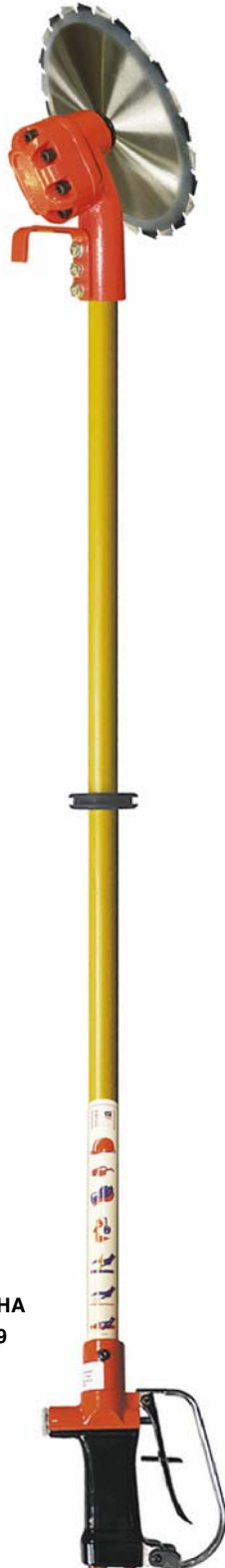

RELIABLE EQUIPMENT & SERVICE CO., INC.

92 STEAMWHISTLE DRIVE • IVYLAND, PA 18974

TOLL FREE: 800-966-3530 • FAX: 215-357-9193

Visit us on the web at www.Reliable-Equip.com



WARNING

BEFORE USING CIRCULAR SAW, READ THE WARNINGS and the recommended practices described in this manual. Failure by the operator to read and fully understand these warnings will leave this person unqualified to use and operate this tool. Property damage, severe personal injury, and/or death could result by not following these warnings.

These warnings will appear in appropriate locations when they are pertinent to the particular subject being shown. Read each one carefully and follow them strictly.



WARNING

Eye Protection

Always wear eye protection to avoid injury from flying debris or hydraulic oil leaks. Failure to do so can result in serious personal injury.



WARNING

Dust Mask

Some timbers may produce irritants. Failure to observe this warning may result in serious health issues and/or breathing difficulty.



WARNING

Hard Hat

Always wear a hard hat to avoid injury from debris. Failure to do so can result in serious personal injury.



WARNING

Foot Protection

Always wear foot protection. Failure to do so can result in serious personal injury.



WARNING

Hearing Protection

Always wear hearing protection, to avoid hearing loss due to long term exposure to high noise levels.



WARNING

Protective Gloves

Always wear hand protection, to avoid cuts, burns, pinching and exposure irritants.



WARNING

Safety

DO NOT attempt to make any changes to any of the component parts or accessories when connected to the power source. **DO NOT** adjust, inspect, or clean tool while the tool is connected to the power source. The tool could accidentally start up and cause serious injury.

DO NOT lock the trigger in the On Position. In an emergency, it is impossible to shut down the tool. Serious damage or injury could occur during the time required to stop the tool.

DO NOT alter or remove the safety latch attached to the trigger. This latch is designed to prevent accidental movement of the trigger, which could cause the chain to start up and cause severe personal injury or property damage.

DO wear protective gloves when handling or adjusting the saw chain. The saw can and will cause damage to the hands without gloves either running or stopped. Failure to follow these warnings can result in serious injury and/or death.



WARNING

Jamming

Jamming or pinching will occur when the wood being cut closes in on top of the blade. This action results in pushback or a kickback, usually very fast with strong force toward the operator. Be careful and be aware of what causes this set of circumstances, so the operator can do everything possible to avoid them.

WARNING

Tip Contact

Accidentally bumping of an object with the tip of the saw may cause a rapid movement of the assembly up and back towards the operator, with possible injury to the operator or damage to the surrounding objects.

WARNING

Worn or Damaged Blade

DO NOT operate this tool with a worn or damaged blade. A worn, damaged, or dull blade will increase the likelihood of kickback or pushback.



WARNING

Burn Hazard

Saw body and blade as well as other components will be hot during and after use. Use care when handling this tool.

Hot surfaces may cause serious burns.

Failure to observe this warning may result in serious injury.



WARNING

Electrical Shock Hazard

Use only certified nonconductive hoses and fittings. Always wear and use the necessary clothing, equipment and safety practices to protect against electrical shock. Failure to follow these rules can result in serious personal injury.

Make certain the fiberglass extension tube is free from moisture, oil, and grease. The accumulation of any or all of the above-mentioned materials will reduce the insulating properties of the fiberglass extension tube.



WARNING

Oil Injection Injury

Hydraulic oil or fluid under the skin is a serious injury. Oil under pressure can penetrate the skin and may cause dismemberment or loss of life. Seek medical assistance immediately if such an injury should occur.

Always wear safety gloves and eye protection when operating or handling.
DO NOT use fingers or hands to attempt to locate a leak.
DO NOT Handle Hoses or Couplers while the hydraulic system is pressurized.
NEVER open or service the system before completely depressurizing.



WARNING

General Safety

Ensure that all fellow employees and bystanders are clear and protected from possible injury caused by this tool or the operations being performed. Persons in close proximity could be injured and property damaged if the tool were to malfunction.

This tool should always be used within the limits and purposes stated by the product manufacturer. Abuse or usage over and above the manufacturers' intended purposes could cause damage to the tool and severe injury to the operator.



WARNING

Burn Hazard

Do Not connect or disconnect tool, hoses or fittings while power source is running or while hydraulic fluid is hot. Hot hydraulic fluid may cause serious burns.
Failure to observe this warning could result in serious injury.



CAUTION

Safe Operation & Care

USE THIS TOOL FOR CUTTING WOOD ONLY, Any other use can result in injury or property damage.

INSPECT TOOL BEFORE USE. Replace any worn, damaged or missing parts. A damaged or improperly assembled tool may malfunction, injuring operator and/or nearby personnel.

INSPECT HYDRAULIC HOSES AND COUPLINGS before each use. Repair or replace if any cracking, leakage, wear or damage is is found. Worn or damaged hoses may fail resulting in personal injury or property damage.

CLEAR WORK AREA of all bystanders and unnecessary personnel before operating this tool. Falling or flying debris could cause serious injury or death.

Failure to observe this warning could result in serious injury.



CAUTION

Safe Handling

HYDRAULIC FLUID MAY CAUSE SKIN IRRITATION.

Handle hydraulic tools and hoses with care to prevent hydraulic fluid from making contact with skin.

IN THE EVENT OF ACCIDENTAL SKIN CONTACT with hydraulic fluid, immediately wash the area thoroughly.

Failure to observe this warning could result in serious injury.



CAUTION

Vibration Hazard

Apply just enough pressure to make the cut. Applying excess pressure to the tool may cause operator discomfort or temporary numbness.

Failure to observe this warning could result in serious injury.

TOOL SPECIFICATIONS

System	Open-Center or Closed Center
Overall Length	82 inches (202.28 cm)
Handle Width	7.5 in. (19.05 cm)
Operating Pressure (Min. - Max.)	1,750 psi (121 bar) - 2,000 psi (138 bar)
Flow (Minimum)	4 gpm (15.1 l/min)
Flow (Recommended)	5 gpm (18.9 l/min)
Flow (Maximum)	6 gpm (22.7 l/min)
Pressure Relief (Maximum)	2,000 psi (138 bar)
Back Pressure (Maximum)	200 psi (13.8 bar)
Pressure & Return Ports	3/8 NPT
Weight with Blade	9.3 lbs. (4.0 kg)
Blade Diameter (Maximum)	9 in. (22.86 cm)
Arbor (DD type)	5/8" x 7/8" (15.88 mm x 22.23 mm)
Blade Rating (Minimum)	5,400 rpm
Cutting Depth	3.5 in. (89 mm)



WARNING

These specifications must be strictly adhered to for this tool to function properly. Any deviation can cause tool damage, severe injury or death. Use only factory specified parts when repairing and/or replacing. Severe tool damage or personal injury may occur with non-specified parts. Always use appropriate blades meeting applicable industrial safety specifications for the use intended by the manufacturer.

Blade must be installed to rotate in the correct direction. Follow the blade manufacturer's instructions and refer to the illustration later in this manual.

Inspect blade for wear or damage before installing and before each use. A damaged blade may break causing a hazard for the operator, other personnel and/or bystanders.

Failure to heed these warnings could result in severe bodily injury or death.

HYDRAULIC FLUIDS

All hydraulic fluids that meet these listed specifications or the listed HTMA specifications may be used for this tool.

@ 100° F (38° C)	140 TO 225 S.U.S.
@ 210° F (99° C)	40 S.U.S. (minimum)
FLASH POINT	340° F min. (170° C min.)
POUR POINT	-30° F min. (-34° C min.)



WARNING

HOSES AND FITTINGS

There exists the potential for shock in using anything other than certified nonconductive hoses and hydraulic oil with dielectric properties, when using system components near energized electrical lines. Failure to recognize these conditions could cause electrocution.

Hoses and fittings used with this tool must comply with S.A.E. J1273 which covers recommended practice for selection, installation, and maintenance of hose and hose assemblies. The **correct hoses and fittings are available from your supplier.**

WARNING: Failure to comply with these warnings could result in severe bodily injury.

UNIT/HOSE CONNECTIONS



WARNING

ALWAYS SHUT OFF pump/power source before connecting or disconnecting system components. **ALWAYS DEPRESSURIZE** hydraulic system before disconnecting this unit or any of the systems components.

ALWAYS TIGHTEN couplings completely. Loose or improperly tightened couplings will not allow fluid to pass through the hose creating a blockage in the supply or return line.



CAUTION

HOSE INSTALLATION

Care must be taken to assure the correct connection of the hoses to the pressure and return ports. If the hoses are incorrectly connected, the tool will run in reverse. This will damage the tool and create dangerous conditions for the operator.

Always inspect hoses and connectors before using this tool each time before using. Replace or repair if any leakage is evident. Leakage is a sign of deterioration in component parts. Worn or leaking parts must be repaired or replaced, or injury and severe damage could result.

PRE-OPERATION OF SAW



WARNING

DO NOT connect hoses or fittings to this unit before completing all of the instructions in this section.

Ensure power source is **OFF**, and hydraulic flow is lever is turned **OFF**.

Failure to comply with this warning can result in severe injury or death.

Before attempting to connect, run, or use the saw, inspect all parts and sub-assemblies, including hoses, couplings, blade assembly, cleanliness of the fiberglass extension, trigger latch, freely moving trigger, and the condition of the rubber behind the trigger.

Worn or damaged parts can cause a malfunction during operation and should be replaced.

Inspect the saw blade for damage. The saw will not function properly with a worn (Dull) or damaged blade. Look for bending, cracking, wear, or any damage to the blade assembly.

A worn or damaged blade could allow pinching, cause kickback, or break creating flying debris that could result in serious injury to the operator, nearby personnel or bystanders.

Set saw to Open or Closed Center, according to which system the power supply pump provides

It is important to know which type of power system is supplying the saw so that the saw can be properly set.

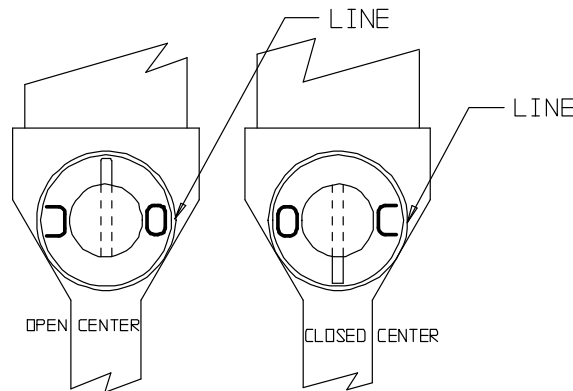

FIGURE 1

Setting Spool Selector for Open Center/Closed Center System

Set the Hand Stop approximately 36" from the handle. This should be a comfortable position for the average person.

Wear all safety items required and make sure that the working area is clear of obstructions.

Ensure all personnel and bystanders are well outside the danger zone.

All of these items are crucial to the safe operating procedure of the saw.

Ensure power source is **OFF**, and hydraulic flow is lever is turned **OFF**.

Connect Saw as described on page 9.

Turn ON hydraulic source and flow control lever. (refer to specifications on page 8)

Allow the power source to run for a few minutes to warm the hydraulic fluid.

Operate newly mounted blades on saw for approximately one minute to ensure proper blade application before cutting material.



OPERATIONAL SAFETY



- There are a number of safety items that need to be addressed when a novice is using the tool for the first time. Seek out the supervisor for basic instruction in handling the tool. Some basic problems are easily overcome by knowing the rules of operation.
- Kickback was described earlier in this manual (see page 5). Read again.
- Kickback occurs when the blade bumps or jams the wood. bumping or jamming the blade will kick the saw up and back toward the operator at lightning speed.
- Unintentionally touching the wood with the top side may push the saw out of the operator's hands. Both situations can cause serious injury and/or damage to the operator, nearby persons, and surrounding equipment.
- Always be aware of the material being cut. Such things as nails and other hard objects can cause kickback, flying debris, blade damage, and/or serious personal injury or death.
- DO NOT use this saw for cutting or clearing at ground level. If the blade contacts the ground or other solid object, the operator may lose control of the saw, the blade may shatter, or flying debris may cause injury to the operator and/or nearby personnel.
- Always run the saw at full speed when cutting.
- Always stand to the side of the cutting path of the blade.
- Never be off balance or overreach while cutting.
- Always wear and use proper safety equipment such as hand and eye protection.
- Always keep the area clear of obstructions and be aware of potential hazards.
- Keep all non-essential personnel out of the danger zone.
- Always be alert to shifting or falling tree limbs. Binding and pinching of the blade may occur and cause difficulty in handling.
- To store the saw between operations, find a clear, flat space and lay the saw down.
- If the saw is out of use for a period of time, shut off the hydraulic power source to prevent unnecessary heat and wear to the saw and hoses.

OPERATION

Hold the fiberglass tube extension in one hand and the handle in the other hand.

After positioning the saw in the cutting area, move the trigger safety latch to a forward position, allowing the trigger to be depressed.

Depress the trigger slowly and allow the blade to start rotating.

When at full speed, feed the saw into the material with constant pressure.

Twisting, jamming or forcing the saw while cutting can cause problems such as kickback, jamming, pulling, or stalling within the cut. This can cause failure and damage to the saw, and/or seriously injure the operator.

Allow the blade to feed steadily and quickly through the work while applying a pressure against the cut. **NOTE:** A slow cut will create excessive heat reducing the life of the blade

When the cut is completed, release the trigger and the saw will stop rotating.

MAINTENANCE

The service schedule should be followed as closely as possible. The life, reliability, and safety of the tool is dependent on maintenance and will help the tool to remain productive for a much longer period.

DAILY MAINTENANCE

CLEAN: All surfaces including handle, trigger, trigger safety latch, fittings, hoses, motor housing, and especially the fiberglass extension tube.

INSPECT: Saw head, blade, handle and trigger assembly for wear and damage. Worn or damaged parts can cause a malfunction during operation. An improperly sharpened blade can cause kickback.

NOTE: A cracked, bent, or damaged blade should be destroyed. A damaged blade may break causing a hazard for the operator, other personnel and/or bystanders.

Visually inspect saw frequently while in use (**NOT RUNNING**). Inspect for tool or blade damage. Inspect for cracked hoses and leaking fittings.

All the above items must be replaced with new parts if signs of wear are evident.

CHECK: Fluid level of power source frequently.

FLUID CONTAMINATION: Cover the ends of fittings with a rubber dust cap when disconnected. This will help keep the fluid from contamination.

MONTHLY MAINTENANCE: Inspect per Appendix A, SAE Standard J1273, 5/86 for hose or fitting damage such as wear, cracks or leakage, replace the necessary parts.

NOTE: Keep Label Set clean and legible. Replace labels as needed. Part # **RL44000**

Contact RELIABLE EQUIPMENT, or your RELIABLE representative if you have any questions related to the information found in this manual.

NOTICE

Read and understand Manual and ALL SAFETY WARNINGS before operation of this tool.

Failure to observe warnings may result in property damage and/or serious personal injury

DANGER

To avoid severe personal injury, inspect tool before each use.

DO NOT operate with loose, missing or damaged fasteners.

CAUTION

DO NOT EXCEED specified flow or pressure

2,000 PSI / 140 BAR
5-7 GPM / 19-26 LPM

Select **Closed Center** for use with Closed Center System.

Select **Open Center** for use with Open Center System.

See Manual for Instructions

DANGER

The saw blade will continue to rotate for up to 5 seconds or more after releasing trigger.

During this coast down time, any contact with the blade may result in property damage, and/or severe personal injury.

After releasing trigger, **DO NOT** place saw on the ground, lower saw into bucket, store saw, or make contact with personnel, bucket, boom or vehicle.

Keep personnel, and bystanders clear of blade, falling limbs, branches and debris.

USE EXTREME CAUTION

Contact at leak or burst may cause an oil injection injury.

WARNING

ELECTRICAL SHOCK HAZARD

Use extreme caution when operating near or around energized cables.



92 Steamwhistle Drive • Ivyland, PA 18974
Phone: 800-966-3530 • Fax: 215-357-9199
Visit us on the web at www.Reliable-Equip.com

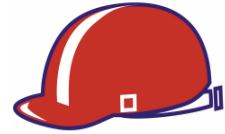

TROUBLE SHOOTING

Will not run

Low hydraulic fluid	Check fluid level
Incorrect viscosity	Use recommended fluid
Tool damaged	Disassemble and replace damaged parts
Hoses incorrectly connected	Switch hoses
Dirt in tool	Disassemble, clean and repair
Loose parts in tool	Check and retighten component parts

Tool runs hot

Low fluid level	Fill pump reservoir to correct level
Fluid viscosity incorrect	Use recommended fluid
Fluid dirty	Drain tank, flush, and replace fluid
Parts worn or damaged	Disassemble and replace worn parts
Fluid supply unit not functioning correctly	Reset to operator manual specs

Tool runs slow

Fluid supply unit not functioning correctly	Reset to operator manual specs.
Fluid not warmed to correct temp	Allow tool a warm-up period
Fluid viscosity too high	See recommended viscosity
Worn or damaged parts	Replace worn parts
Dirt or contaminants in tool	Disassemble and clean
Internal parts worn	Replace worn parts
Hydraulic level low	Fill to level. Check for leaks

Tool is erratic

Hydraulic fluid not warm	Allow oil to warm up
Dirt or contaminants in tool	Clean and reassemble
Air in system	Check hoses for breaks, leaks, or loose connections

Tool leaks hydraulic fluid

Worn or damaged seals	Disassemble and replace worn or damaged seals
Component screws loose	Tighten all fasteners

Tool won't shut off

Tool trigger spool sticky	Clean up spool so that spool slides freely
Check for misalignment	Align trigger linkage

Tool lacks power

Control valve leaking	Worn part or seal rings
-----------------------------	-------------------------

Tool runs but does not cut

Saw blade is dull	Resharpener or replace
Damaged components	Replace components

Tool runs backwards

Hoses misconnected	Reverse the hoses
--------------------------	-------------------

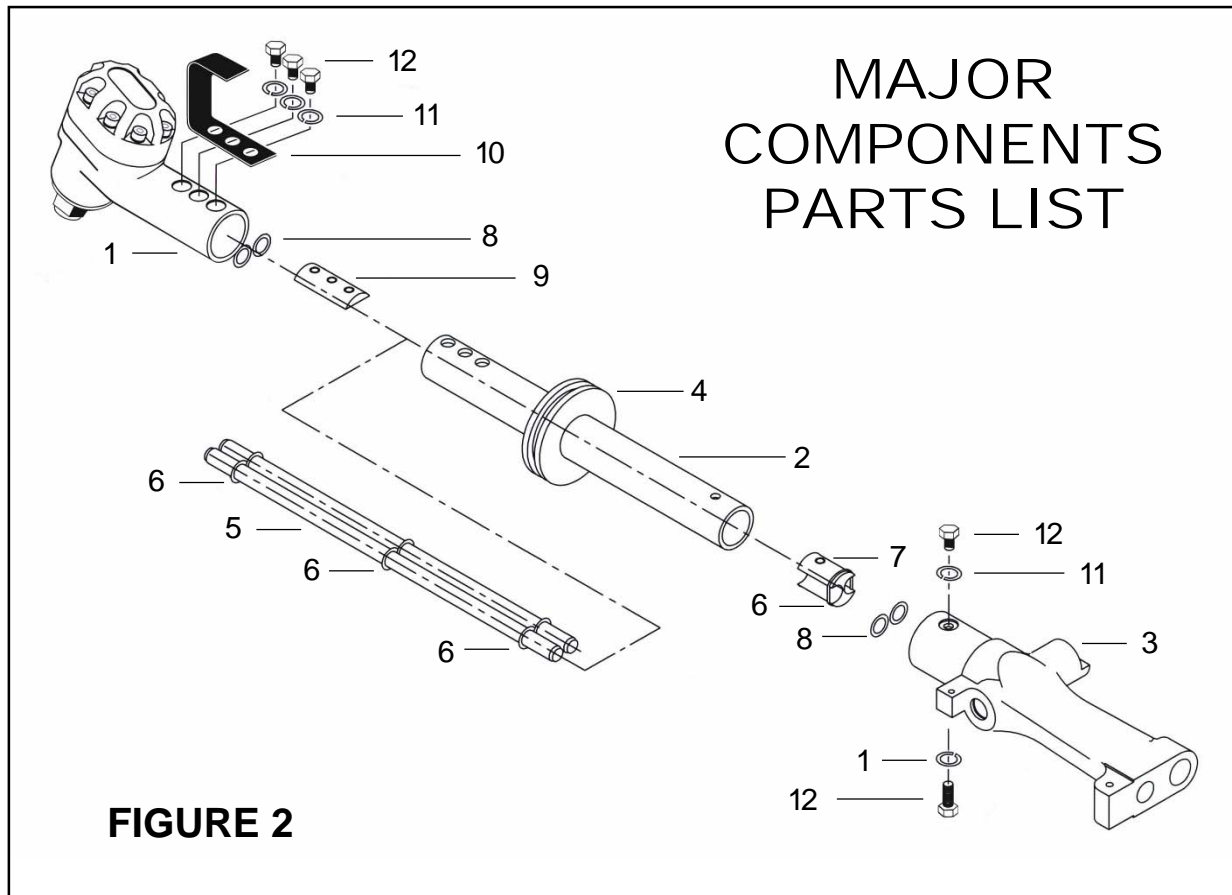

Key	Part No	Description	Qty.
1*	R44001BCM	Head Assembly	1
2	R44012	Outer Tube	1
3	R44014	Handle Body	1
4	13422	Grommet	1
5	R44013	Inner Tube	2
6	13425	Rubber Straps (O-Ring)	4
7	13416	Rear Tube Support	1
8*	13447	Internal O-Ring	4
9	13415	Front Tube Support	1
10	R44006	Hanger Bracket	1
11	13129	Lock Washer	5
12	13497	Hex Bolt	5
13	RL44000	Label Set	1

FIGURE 3

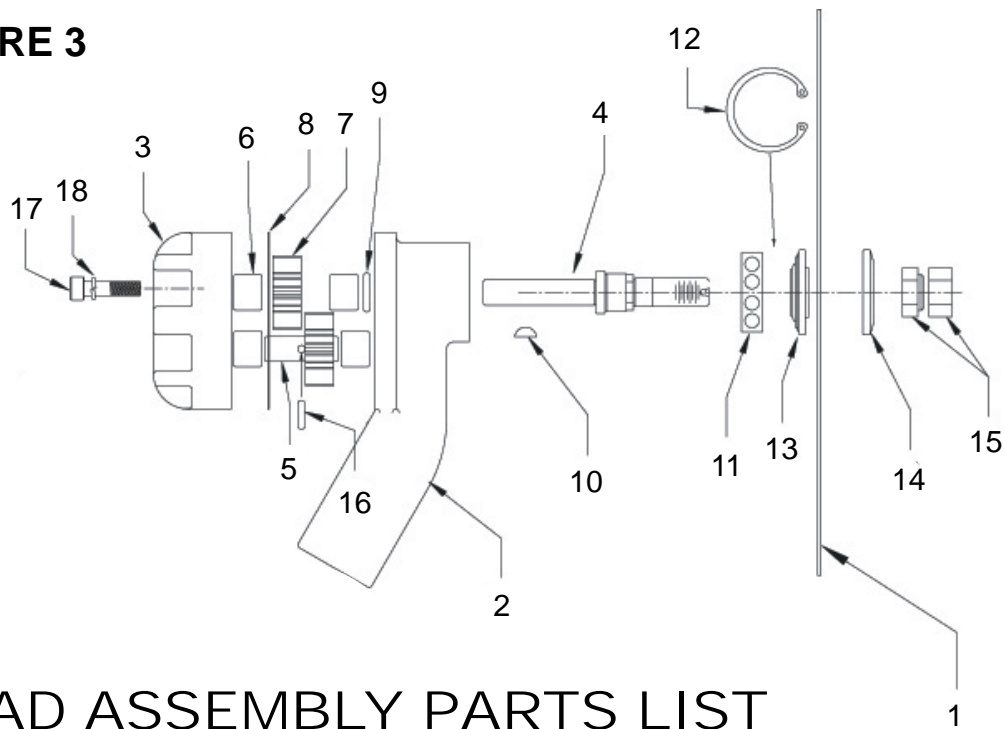

HEAD ASSEMBLY PARTS LIST

Key	Part No	Description	Qty.
1	34356	Blade	1
2	44001B	Head with Bearings	1
3	13106	Motor Cap with Bearings	1
4	R44002	Drive Shaft	1
5	13140	Idler Shaft	1
6	13435	Needle Bearing	2
7	12875	11 Tooth Gear	1
8	13436	Motor Gasket	1
9*	13439	O-Ring	1
10	13427	Woodruff Key	1
11	13411	Sealed Bearing	1
12	13434	Snap Ring, Bearing	1
13	R44005	Locating Washer	2
14	R44007	Washer	2
15	R44004	Split Nut	2
16	12795	Drive Pin	2
17	13128	Motor Head Screws	2
18	13438	1/4" Lockwasher	2

HANDLE PARTS LIST

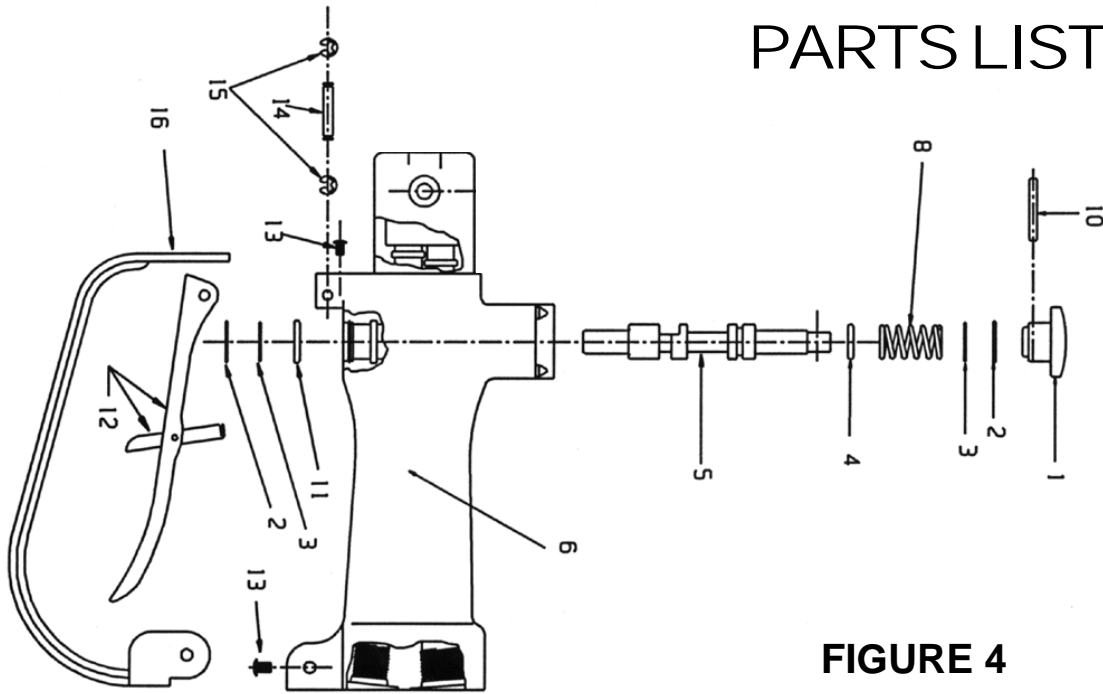

FIGURE 4

Key	Part No	Description	Qty.
	13402CHA	Complete Handle Assy.	1
1	13421	OC/CC Knob	1
2*	13423	Snap Ring	2
3*	13424	Spool Retainer Washer	2
4*	13414	O-Ring	1
5	13420	Spool	1
6	13402	Handle Body	1
7	13428	Spool Spring	1
8	13445A	Spring Pin	1
9*	13417	O-Ring, Internal	1
10	13490	Trigger with safety	1
11	13441	10-32 Screw	3
12	13430	Trigger Pin	1
13	13457	Snap Ring	2
14	13432	Trigger Guard	1



WARNING

Before any disassembly, disconnect hoses from the saw!

Any residual pressure within the unit can and will spray at high velocity, injuring the person doing the disassembly. Hot or pressurized hydraulic fluid will cause serious injury to the body! Accidental movement of the blade can cause serious injury, dismemberment of a hand, finger or any other part of the body.

Complete disassembly is not recommended. Return the unit to an authorized dealer for total disassembly and/or repair.

All maintenance or disassembly should take place on a flat, clean work surface covered with towels or wipers so as to have a clean space for the disassembled parts.

Inspect each part during disassembly for damage wear, scratches, and cuts.

Discard the worn or damaged parts and replace with new parts.

O-rings are sensitive to sharp edges. Inspect closely for cuts or damage. A small cut will cause a leak. When assembling or disassembling O-rings, use hydraulic fluid as a lubricant to help disassembly or installation.

DISASSEMBLY BLADE AND MOTOR ASSEMBLY

Refer to Figure 3, Page 15

1. Remove the Split Nut (15) by turning the upper nut in the clockwise direction while securing the lower nut and shaft in place.
2. Remove lower nut by turning in the clockwise direction.
3. Remove the Blade Washer (14).
4. Remove the Blade (1) from the Locating Washer (13).
5. Lift Locating Washer (13) Off of Shaft (4)



Motor disassembly: Remove 8 screws (18) and lift motor cap (17) off. Remove motor gears (14), gasket (16) and idler shaft (15). Bearings (12) and (13) should not need to be removed unless extreme wear has occurred. Bearing replacement would be a factory function only.

Contact RELIABLE EQUIPMENT at 800-966-3530 if you have any questions related to the instructional information found in this manual.

BLADE INSTALLATION (Refer to Figure 3, Page 15)



WARNING

These specifications must be strictly adhered to for this tool to function properly. Any deviation can cause tool damage, severe injury or death. Use only factory specified parts when repairing and/or replacing. Severe tool damage or personal injury may occur with non-specified parts. Always use appropriate blades meeting applicable industrial safety specifications for the use intended by the manufacturer.

Blade must be installed to rotate in the correct direction. Follow the blade manufacturer's instructions and refer to the illustration later in this manual.

Inspect blade for wear or damage before installing and before each use. A damaged blade may break causing a hazard for the operator, other personnel and/or bystanders.

Failure to heed these warnings could result in severe bodily injury or death.

Inspect all parts for wear or damage before replacing the blade. Replace as needed. Inspect blade for wear, bending, cracking or damage. (Discard or destroy damage blades.)

1. Install the Blade (1) onto the Locating Washer (13).
2. Slide the Blade Washer (14).
3. Install lower portion of the Split Nut (15) by turning in the counterclockwise direction.
4. Install the Split Nut (15) onto shaft and lower nut by turning the upper nut in the counterclockwise direction while securing the lower nut and shaft in place.



VALVE/HANDLE DISASSEMBLY

(Refer to Figure 4, Page 16)

Remove the three button head screws (13) holding the trigger guard to the valve body. Remove one snap ring (15) from the pin (14), holding the trigger to the valve body, and remove pin. Before removing the control knob (1), mark the relative position to the spool (5). Remove pin (6) from spool (5). Remove retaining ring (2) and remove knob (1) from the spool (5). Remove washer (3) and spring (8). If there is a problem with the O-ring (11), remove the bottom retaining ring (2), the bottom washer and with an O-ring removal tool, remove O-ring (11) for inspection.

Contact RELIABLE EQUIPMENT at 800-966-3530 if you have any questions related to the instructional information found in this manual.

TUBE DISASSEMBLY (Refer to Figure 2, Page 14)

Removal of Tube Assembly from Valve

Remove two screws (9) from valve body. Gently slide outer tube (3) from valve (10).

Removal of Tube Assembly from Motor Housing - Remove three bolts and lockwashers (12) from motor housing. Gently slide outer tube (3) away from motor housing.

Removal of Inner Tubes (5 and 6) from Outer Tube (3). Pull inner tubes from outer tube. Three O-rings (7) have been twisted into a figure 8 and slid over the two-tube assembly to hold the two tubes together and in alignment. Make sure that they are aligned properly. The inner tubes as depicted in Fig. 4 show the relative position of the pressure and return tube to the other components. Be sure that the inner tube assembly is in the position shown relative to the valve and the motor head.

ASSEMBLE TUBES (See Figure 2, Page 14)

Tie the two inner tubes together with the three O-rings (7) twisted in a figure 8 configuration. The pressure tube (6) is marked with blue ink on each end. The return tube (5) has no marking. As shown in Fig. 4, the pressure tube closest to the bottom of the page. The return tube is shown above the pressure tube. Tubes must be fitted into the Rear Tube Support (8) with the O-ring around its end (shown on the right.)

The outer tube support can be inserted after placing it over the inner tubes and aligning it with the three holes in the head casting. Internal O-rings (1) should be replaced after disassembly. Remove and replace. Slide inner tubes (5 and 6) into their proper sockets with extreme care. The sockets can be seen in a cutaway section in Fig. 7. Be sure that the ends of the inner tubes are clean and free of burrs and tears so as not to cut or scratch the O-rings. Install the three oval head screws (11) and two button head screws (9).

ASSEMBLE VALVE/HANDLE BODY

(See Figure 4, Page 16)

Install O-ring (11) in the groove near the bottom of the Spool Cavity, followed by Washer (3) and Retaining Ring (2).

Install O-ring (4) on Spool (5) being careful not to cut the ring when passing over sharp corners. Lubricate the Spool and slide it gently in the Valve Body. Install the Spring (8) followed by the Washer (3) and the Retaining Ring (2).

Install Knob (1) and Pin (6) in the Spool (5). Care must be taken to achieve the correct rotational position of the OC/CC markings in relation to certain features of the spool (5). There is a small flat on the spool where the Knob goes on. When this flat is facing up, the C on the back of the Knob (for closed center) is facing right.

Install the Trigger Assembly with the Pin (14) and the Snap Rings (15), followed by the Trigger Guard (16) using the Button Head Screws (13).



WARNING

Operation/Safety methods may vary in accordance with the working guidelines established by each Utility or Contractor.

For your own safety, ensure that you fully comply with all safe operation guidelines required by your employer.



MAINTENANCE RECORD

Date	Parts or Service Required

If you have any questions regarding the information in this manual please contact **RELIABLE EQUIPMENT** at the address, phone or fax numbers shown below.



RELIABLE EQUIPMENT & SERVICE CO., INC.

92 Steamwhistle Drive • Ivyland, PA 18974
Phone: 800-966-3530 • Fax: 215-357-9193
Visit us on the web at www.Reliable-Equip.com