

# OPERATORS' GUIDE

## LR-88.5 / LR-75 / LR-62.5

### HYDRAULIC LONG REACH CHAINSAW



For cutting and trimming of limbs and branches from the ground or an aerial bucket that a standard chainsaw could not reach.

#### WARNING



All information found in this guide must be read and understood before use or testing of this tool. Failure to read and understand these warnings and safe handling instructions could result in severe personal injury and or death.

DISTRIBUTED BY

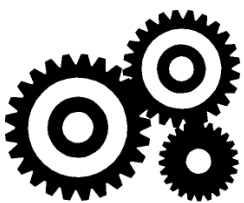

# RELIABLE EQUIPMENT & SERVICE CO., INC.

LR Manual 05-08

# TABLE OF CONTENTS

Saw Description .....	2	<b>PARTS LISTS</b>	
Registration .....	2	<b>Major Components.....</b>	<b>15</b>
Safety Instructions .....	3-6	<b>Head, motor side .....</b>	<b>16</b>
<b>SPECIFICATIONS</b>		<b>Head, chain side .....</b>	<b>17</b>
<b>General .....</b>	<b>7</b>	<b>Handle .....</b>	<b>18</b>
<b>Connections and Hoses .....</b>	<b>8</b>	<b>REPAIR INSTRUCTIONS</b>	
<b>Pre-Operation .....</b>	<b>9</b>	<b>Disassembly .....</b>	<b>19-20</b>
<b>Spool Selector .....</b>	<b>9</b>	<b>Assembly .....</b>	<b>.21</b>
<b>Operation of Saw .....</b>	<b>10</b>	<b>Product Update.....</b>	<b>.22</b>
<b>MAINTENANCE</b>		<b>Parts Order Form.....</b>	<b>23</b>
<b>General .....</b>	<b>11</b>		
<b>Chain Oiler .....</b>	<b>12</b>		
<b>Chain Tension .....</b>	<b>.13</b>		
<b>Troubleshooting .....</b>	<b>14</b>		

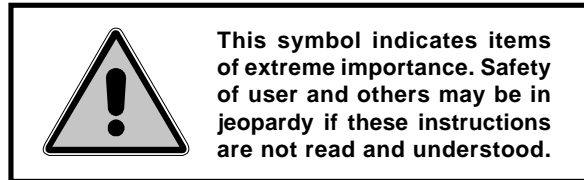

---

## DESCRIPTION

The long reach chainsaw is intended for safely cutting and trimming trees which are out of reach of the ordinary chain saw. The powerful hydraulic drive motor can easily make cuts of 12 inch diameter from the ground or an aerial bucket. With an overall length of 88.5 inches, the operator is easily able to reach the areas not possible with a standard chain saw.

The dielectric property of the fiberglass extension tube will reduce the chance of electric shock when used near an energized electric line. Other features include a trigger guard to prevent accidental movement of the chain, a covered sprocket guard, and a rubber collar hand stop. A quick set spool can be turned 180 degrees for closed center/open center operations.

**UPON RECEIPT OF THIS TOOL, COMPLETE THE REGISTRATION BELOW.**

**SERIAL NUMBER** \_\_\_\_\_

**DATE OF PURCHASE** \_\_\_\_\_

**DEALER NAME** \_\_\_\_\_



**WARNING**

BEFORE USING THIS CHAINSAW, READ THE WARNINGS and the recommended practices described in this manual. Failure by the operator to read and fully understand these warnings will leave this person unqualified to use and operate this tool. Property damage, severe personal injury, and/or death could result by not following these warnings.

These warnings will appear in appropriate locations when they are pertinent to the particular subject being shown. Read each one carefully and follow them strictly.



**Eye Protection**

**WARNING**

Always wear eye protection to avoid injury from flying debris or hydraulic oil leaks. Failure to do so can result in serious personal injury.



**Dust Mask**

**WARNING**

Some timbers may produce irritants. Failure to observe this warning may result in serious health issues and/or breathing difficulty.



**Hard Hat**

**WARNING**

Always wear a hard hat to avoid injury from debris. Failure to do so can result in serious personal injury.



**Foot Protection**

**WARNING**

Always wear foot protection. Failure to do so can result in serious personal injury.



**Hearing Protection**

**WARNING**

Always wear hearing protection, to avoid hearing loss due to long term exposure to high noise levels.



Operation/Safety methods may vary in accordance with the working guidelines established by each utility or contractor.

**WARNING**

For your own safety, ensure that you fully comply with all safe operation guidelines required by your employer.



## Safety

### WARNING

**DO NOT** attempt to make any changes to any of the component parts or accessories when connected to the power source.

**DO NOT** adjust, inspect, or clean tool while the tool is connected to the power source. The tool could accidentally start up and cause serious injury.

**DO NOT** lock the trigger in the On Position. In an emergency, it is impossible to shut down the tool. Serious damage or injury could occur during the time required to stop the tool.

**DO NOT** alter or remove the safety latch attached to the trigger. This latch is designed to prevent accidental movement of the trigger, which could cause the chain to start up and cause severe personal injury or property damage.

**DO** wear protective gloves when handling or adjusting the saw chain. The saw can and will cause damage to the hands without gloves either running or stopped. Failure to follow these warnings can result in serious injury and/or death.



## Jamming

### WARNING

Jamming or pinching will occur when the wood being cut closes in on the top of the chain or guide. This action results in pushback or a kickback, usually very fast with strong force toward the operator. Be careful and be aware of what causes this set of circumstances, so the operator can do everything possible to avoid them.

### WARNING

## Tip Contact

Accidentally touching an object with the tip of the chainsaw can cause a rapid movement of the assembly up and back towards the operator, with possible injury to the operator or damage to the surrounding objects.

### WARNING

## Worn or Damaged Saw Chain

**DO NOT** operate this tool with a worn or damaged saw chain. Worn, damaged, or dull saw chain will increase the likelihood of kickback or pushback.



**WARNING**

## Burn Hazard

Saw body, blade, bar as well as other components will be hot during and after use. Use care when handling this tool. Hot surfaces may cause serious burns. Failure to observe this warning may result in serious personal injury.



**WARNING**

## Electrical Shock Hazard

Use only certified nonconductive hoses and fittings. Always wear and use the necessary clothing, equipment and safety practices to protect against electrical shock. Failure to follow these rules can result in serious personal injury.

Make certain the fiberglass extension tube is free from moisture, oil, and grease. The accumulation of any or all of the above-mentioned materials will reduce the insulating properties of the fiberglass extension tube.



**WARNING**

## Oil Injection Injury

Hydraulic oil or fluid under the skin is a serious injury. Oil under pressure can penetrate the skin and may cause dismemberment or loss of life. Seek medical assistance immediately if such an injury should occur.

Always wear safety gloves and eye protection when operating or handling.

**DO NOT** use fingers or hands to attempt to locate a leak.

**DO NOT** Handle Hoses or Couplers while the hydraulic system is pressurized.

**NEVER** open or service the system before completely depressurizing.



**WARNING**

## General Safety

Ensure that all fellow employees and bystanders are clear and protected from possible injury caused by this tool or the operations being performed. Persons in close proximity could be injured and property damaged if the tool were to malfunction.

This tool should always be used within the limits and purposes stated by the product manufacturer. Abuse or usage over and above the manufacturers' intended purposes could cause damage to the tool and severe injury to the operator.



**WARNING**

## Burn Hazard

Do Not connect or disconnect tool, hoses or fittings while power source is running or while hydraulic fluid is hot. Hot hydraulic fluid may cause serious burns.

Failure to observe this warning could result in serious injury.



**CAUTION**

## Safe Operation & Care

USE THIS TOOL FOR CUTTING WOOD ONLY, Any other use can result in injury or property damage.

INSPECT TOOL BEFORE USE. Replace any worn, damaged or missing parts. A damaged or improperly assembled tool may malfunction, injuring operator and/or nearby personnel.

INSPECT HYDRAULIC HOSES AND COUPLINGS before each use. Repair or replace if any cracking, leakage, wear or damage is found. Worn or damaged hoses may fail resulting in personal injury or property damage.

CLEAR WORK AREA of all bystanders and unnecessary personnel before operating this tool. Falling debris could cause serious injury or death.

Failure to observe this warning could result in serious injury.



**CAUTION**

## Safe Handling

HYDRAULIC FLUID MAY CAUSE SKIN IRRITATION.

Handle hydraulic tools and hoses with care to prevent hydraulic fluid from making contact with skin.

IN THE EVENT OF ACCIDENTAL SKIN CONTACT with hydraulic fluid, immediately wash the area thoroughly.

Failure to observe this warning could result in serious injury.



**CAUTION**

## Vibration Hazard

Apply just enough pressure to make the cut. Applying excess pressure to the tool may cause operator discomfort or temporary numbness.

Failure to observe this warning could result in serious injury.

# TOOL SPECIFICATIONS

Overall Length .....	<b>62.5 in., 75 in., 88.5 in.</b>
Handle Width .....	<b>7.5 in. (19.05 cm)</b>
Motor Width .....	<b>5 in. (11.43 cm)</b>
Weight.....	<b>9.5 lbs. (4.22 kg)</b>
Cutting Chain @ 8GPM (30 ipm) .....	<b>4,200 fpm/<u>min</u> (1,280 m/min)</b>
Pitch .....	<b>.325 in. (8.26 mm)*</b>
Chain Gauge.....	<b>.058 in. (1.47 mm)*</b>
Chain Bar Length .....	<b>15.375 in. (39.05 cm)*</b>
Rated Feet per Minute, <u>Minimum</u> .....	<b>4,200 (1,280 m)*</b>



**WARNING**

These specifications must be strictly adhered to for this tool to function properly. Any deviation can cause severe injury or death. Use only factory specified parts when repairing and/or replacing. Severe damage to the tool can occur with non-specified parts.



**WARNING**

Always use chains rated for 4,200 FPM (1,280 MPM) or higher. Always use chains that meet applicable safety code specifications. Failure to heed these warnings could result in severe bodily injury.

## HYDRAULIC FLUIDS

All hydraulic fluids that meet these listed specifications or the listed HTMA specifications may be used for this tool.

**S. U. S.** \_\_\_\_\_

**@ 100° F (38° C) .....** **140 TO 225**

**@ 210° F (99° C) .....** **40 minimum**

**FLASH POINT .....** **340° F min. (170° C min.)**

**POUR POINT.....** **-30° F min. (-34° C min.)**



**WARNING**

## HOSES AND FITTINGS

There exists the potential for shock in using anything other than certified nonconductive hoses and hydraulic oil with dielectric properties, when using system components near energized electrical lines. Failure to recognize these conditions could cause electrocution.

Hoses and fittings used with this tool must comply with S.A.E. J1273 which covers recommended practice for selection, installation, and maintenance of hose and hose assemblies. The **correct hoses and fittings are available from your supplier.**

**WARNING:** Failure to comply with these warnings could result in severe bodily injury.

---

## UNIT/HOSE CONNECTIONS



**WARNING**

**ALWAYS SHUT OFF** pump/power source before connecting or disconnecting system components. **ALWAYS DEPRESSURIZE** hydraulic system before disconnecting this unit or any of the systems components.

**ALWAYS TIGHTEN** couplings completely. Loose or improperly tightened couplings will not allow fluid to pass through the hose creating a blockage in the supply or return line.



**CAUTION**

## HOSE INSTALLATION

Care must be taken to assure the correct connection of the hoses to the pressure and return ports. If the hoses are incorrectly connected, the tool will run in reverse. This will damage the tool and create dangerous conditions for the operator. Always inspect hoses and connectors before using this tool each time before using. Replace or repair if any leakage is evident. Leakage is a sign of deterioration in component parts. Worn or leaking parts must be repaired or replaced, or injury and severe damage could result.

# PRE-OPERATION OF SAW

**WARNING! DO NOT** connect hoses or fittings to this chainsaw before completing all the following instructions.

Before attempting to run or use the saw, check all connections, including hoses, couplings, chain tension, cleanliness of the fiberglass extension, trigger latch, freely moving trigger, and the condition of the rubber behind the trigger. Wear all safety items required and make sure that the working area is clear of obstructions. Set saw to Open or Closed Center, according to which system the power supply pump provides. It is important to know which type of power system is supplying the saw so that the chainsaw can be properly set. All these items are crucial to the safe operating procedure of the chainsaw.

## Setting Spool Selector for Open Center/Closed Center System

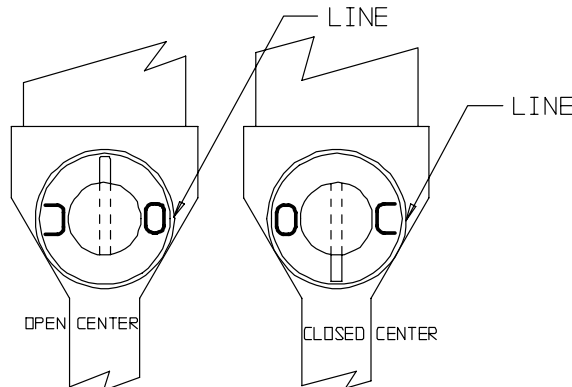

**FIGURE 1**

Make sure hoses are disconnected from the chainsaw and inspect the following items: Inspect the saw chain. The chain tension should be set per Fig. 3. If the tension is too tight, the saw guide will wear excessively. If the tension is too loose, the chain could jump the track. Follow the settings as described in Fig. 3.

Set the automatic oiler as described in Fig. 2. If set properly, a fine mist should show at the tip of the chain. Too much fluid will drain the reservoir of oil. Follow the instructions on page 11. Check the fluid level regularly for fluid loss.

Inspect the chain for damage. The saw will not function properly with a worn or damaged chain. Look for bending, wear, or any damage to the chain assembly.

Damaged chain assemblies could cause pinching or kickback, resulting in serious injury to the operator.

Set the Hand Stop approximately 36" from the handle (shown as item 4 on page 15.) This should be a comfortable position for the average person.

### CAUTION

**New saw chains require a break-in period. The chain tension will need to be adjusted frequently as described on page 12.**

# OPERATION

Hold the fiberglass tube extension in one hand and the handle in the other hand. After positioning the saw in the cutting area, move the trigger safety latch to a forward position, allowing the trigger to be depressed. Depress the trigger slowly and allow the chain to start rotating. When at full speed, feed the saw into the material. Twisting or jamming the saw while cutting can cause problems such as kickback, jamming, pulling, or stalling within the cut. This can cause failure and damage to the saw. This can also seriously injure the operator. (See Safety Instructions) Allow the chain blade to do the work while applying a pressure against the cut. When the cut is completed, release the trigger and the saw will stop rotating.

## OPERATIONAL SAFETY

- There are a number of safety items that need to be addressed when a novice is using the tool for the first time. Seek out the supervisor for basic instruction in handling the tool. Some basic problems are easily overcome by knowing the rules of operation.
- Kickback was described earlier in this manual (see page 4). Read again.
- Kickback occurs when the tip of the blade touches the wood. Faithfully avoid touching the wood at either the tip or the top side of the blade. Touching the tip will kick the saw up and back toward the operator at lightning speed.
- Touching the wood with the top side will pull the saw out of the operator's hands. Both situations can cause serious injury and/or damage to the operator, nearby persons, and surrounding equipment.
- Always be aware of the material being cut. Such things as nails and other hard objects can cause kickback and damage to the chain blade. This will cause a serious malfunction.
- Always run the chain at full speed when cutting.
- Always stand to the side of the cutting path of the chain.
- Never be off balance or overreach while cutting.
- Always wear and use proper safety equipment such as hand and eye protection.
- Always be alert to shifting or falling tree limbs. Binding and pinching of the chainblade will occur and cause difficulty in handling.
- To store the chainsaw between operations, find a clear, flat space and lay the saw on the space. Another option is to hang the chainsaw in an out of the way space.
- If the chainsaw is out of use for a period of time, shut off the hydraulic power source to prevent unnecessary heat and wear on the chainsaw and hoses.

# MAINTENANCE

The service schedule should be followed as closely as possible. The life, reliability, and safety of the tool is dependent on maintenance and will help the tool to remain productive for a much longer period.

## DAILY MAINTENANCE

**CLEAN:** All surfaces including handle, trigger, trigger safety latch, fittings, hoses, motor housing, and especially the fiberglass extension tube.

**INSPECT:** Saw chain for wear and damage. Worn or damaged parts can cause kickback during operation. Improperly sharpened chain components can cause a malfunction. Inspect saw frequently while in use (**NOT RUNNING**). Inspect for damage and tension. Inspect for cracked hoses and leaking fittings.

**CHECK:** Fluid level of the power source reservoir frequently. The automatic oiler uses hydraulic fluid for the bar and chain, this will cause the fluid level to drop.

**All the above items must be replaced with new parts if signs of wear are evident.**

**ADJUST:** Saw chain and automatic oiler. Too much or too little tension will wear the chain. Insufficient oil will wear the saw chain and the chain guide, and cause heat to build up at the tip where most of the wear occurs. The automatic oiler should allow oil to show at the tip as a fine mist when the saw is running at full speed.

**FLUID CONTAMINATION:** Cover the ends of fittings with a rubber dust cap when disconnected. This will help keep the fluid from contamination.

**MONTHLY MAINTENANCE:** Inspect per Appendix A, SAE Standard J1273, 5/86 for hose or fitting damage such as wear, cracks or leakage, replace the necessary parts.

**NOTE:** Keep decals clean and legible. Replace decals when necessary. Part #RL13400

Date	Parts or Service Required

# SERVICE

## Automatic Chain Oiler:

The automatic chain oiler is designed to continuously lubricate the chain and the guide bar while the chainsaw is running. This lubrication is an important factor in minimizing wear and tear on components as is commonly found in chainsaws. By utilizing the fluid from the supply circuit and sending the fluid through a metering valve, the fluid is then directed to the chain and guide in the quantity required. By adjusting the metering screw, fluid can be applied at a greater or lesser volume, depending on the usage of the chainsaw.

**IMPORTANT:** Check the operation of the automatic oiler frequently.

### Adjusting the Automatic Oiler: Fig. 2



**WARNING: Disconnect the hydraulic source! Severe injury can occur if the power is on and the saw starts running accidentally!**

A slotted head metering screw will be found at the position shown in Fig. 2.

Turn the screw counterclockwise to increase the oil flow. To decrease the flow, turn the screw clockwise. Make adjustments by turning no more than  $\frac{1}{2}$  turn. Run the saw at full speed and watch the end of the saw. If a fine mist appears at the end while running, then it is adjusted properly. If there is no visible mist, make another adjustment counterclockwise.

If adjusting an older unit and change in flow occurs while running, clean the oil outlet hole under the end of the chain bar. It may have become clogged with debris.

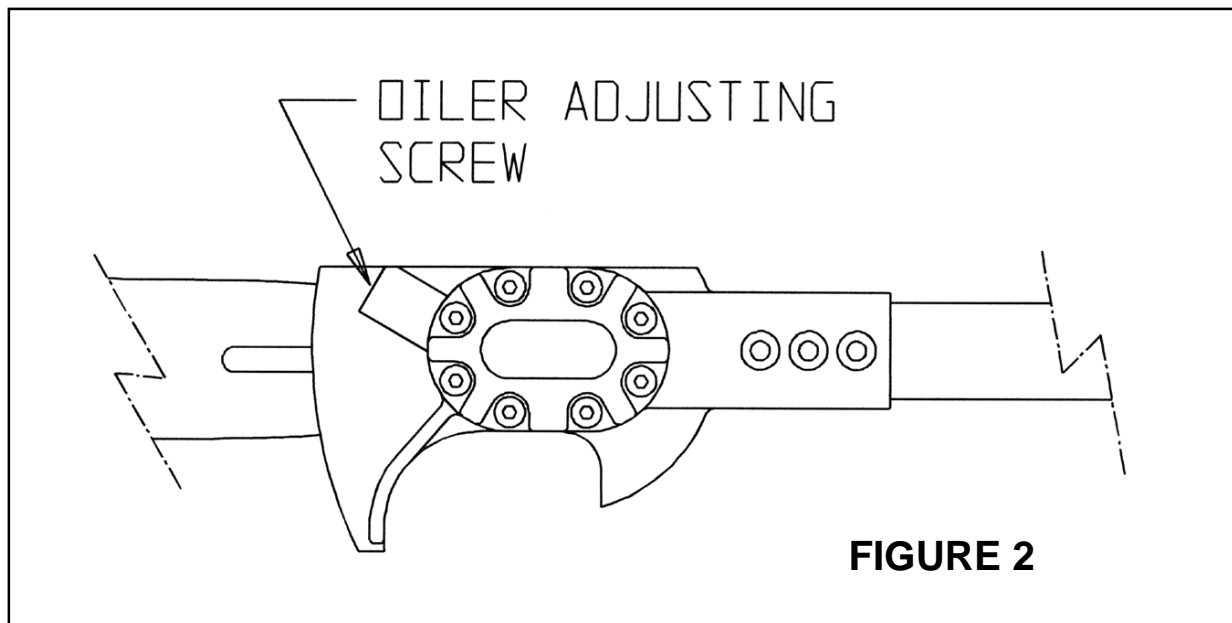

## Saw Chain Tension:

Tension checking and adjusting must be done frequently before start and during cutting operations. The chain must be set to the proper tension in order for the saw to function properly. If the chain is too loose, the chain can jump the track of the guide bar, probably causing damage to the bar and associated components. If the chain is adjusted too tight, heat and wear will ruin the guide bar.

## Setting Tension:

Disconnect Hoses or shut off the hydraulic supply system before making adjustments. The adjusting screw is in the motor, head, and drive unit. Check tension by pulling the chain at the bottom side (Fig. 8) away from the guide with a two-pound (approx.) pull. If the chain pulls away more than 1/8", the chain is too loose. Less than 1/8" is too tight. Loosen the two mounting screws that hold the chain bar to the frame. Turn the adjusting screw counterclockwise to loosen tension, clockwise to increase tension. Retighten mounting screws and recheck tension. Tightening mounting screws may alter the setting. If necessary, repeat the process until the chain has 1/8" space between the chain and guide.

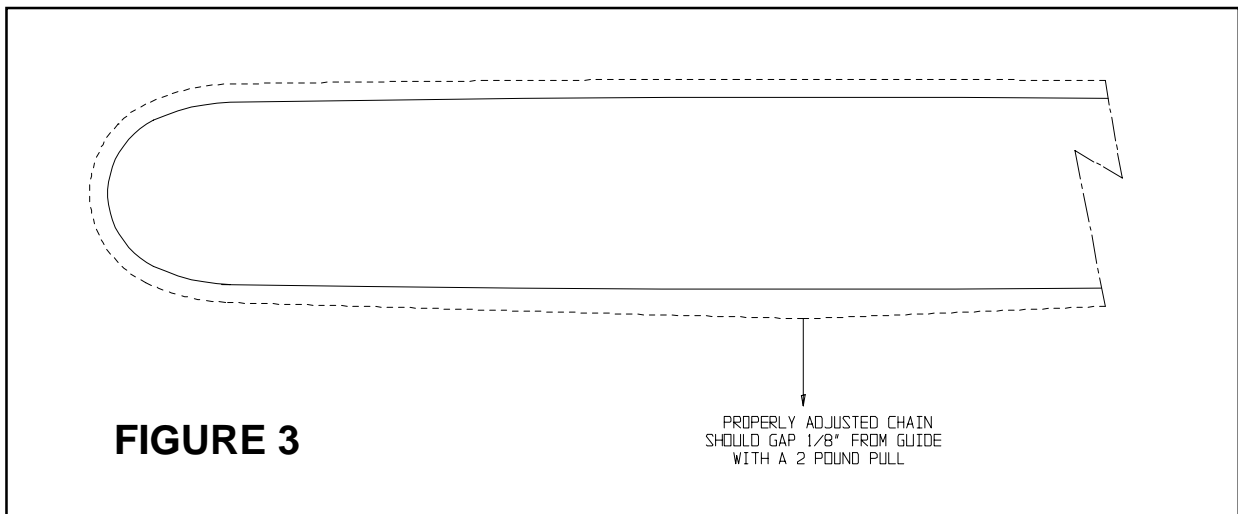

# TROUBLE SHOOTING

## Will not run

Low hydraulic fluid .....	Check fluid level
Incorrect viscosity .....	Use recommended fluid
Tool damaged .....	Disassemble and replace damaged parts
Hoses incorrectly connected .....	Switch hoses
Dirt in tool .....	Disassemble, clean and repair
Loose parts in tool .....	Check and retighten component parts

## Tool runs hot

Low fluid level .....	Fill pump reservoir to correct level
Fluid viscosity incorrect .....	Use recommended fluid
Fluid dirty .....	Drain tank, flush, and replace fluid
Parts worn or damaged .....	Disassemble and replace worn parts
Fluid supply unit not functioning correctly .....	Reset to operator manual specs

## Tool runs slow

Fluid supply unit not functioning correctly .....	Reset to operator manual specs.
Fluid not warmed to correct temp .....	Allow tool a warm-up period
Fluid viscosity too high .....	See recommended viscosity
Worn or damaged parts .....	Replace worn parts
Dirt or contaminants in tool .....	Disassemble and clean
Internal parts worn .....	Replace worn parts
Hydraulic level low .....	Fill to level. Check for leaks

## Tool is erratic

Hydraulic fluid not warm .....	Allow oil to warm up
Dirt or contaminants in tool .....	Clean and reassemble
Air in system .....	Check hoses for breaks, leaks, or loose connections

## Tool leaks hydraulic fluid

Guide bar oil port clogged .....	Clean oil slot under motor assy under guide bar
Worn or damaged seals .....	Disassemble and replace worn or damaged seals
Component screws loose .....	Tighten all fasteners

## Tool won't shut off

Tool valve spool sticky .....	Clean up spool so that spool slides freely
Check for misalignment .....	Align trigger linkage

## Tool lacks power

Chain adjusted too tight .....	Adjust chain as shown in "Adjusting Tension"
Control valve leaking .....	Worn part or seal rings

## Tool runs but does not cut

Saw is dull .....	Resharpener or replace
Saw chain damaged .....	Replace chain
Damaged components .....	Replace components
Worn Guide Bar .....	Replace with new part

## Tool runs backwards

Hoses misconnected .....	Reverse the hoses
--------------------------	-------------------

# MAJOR COMPONENTS PARTS LIST

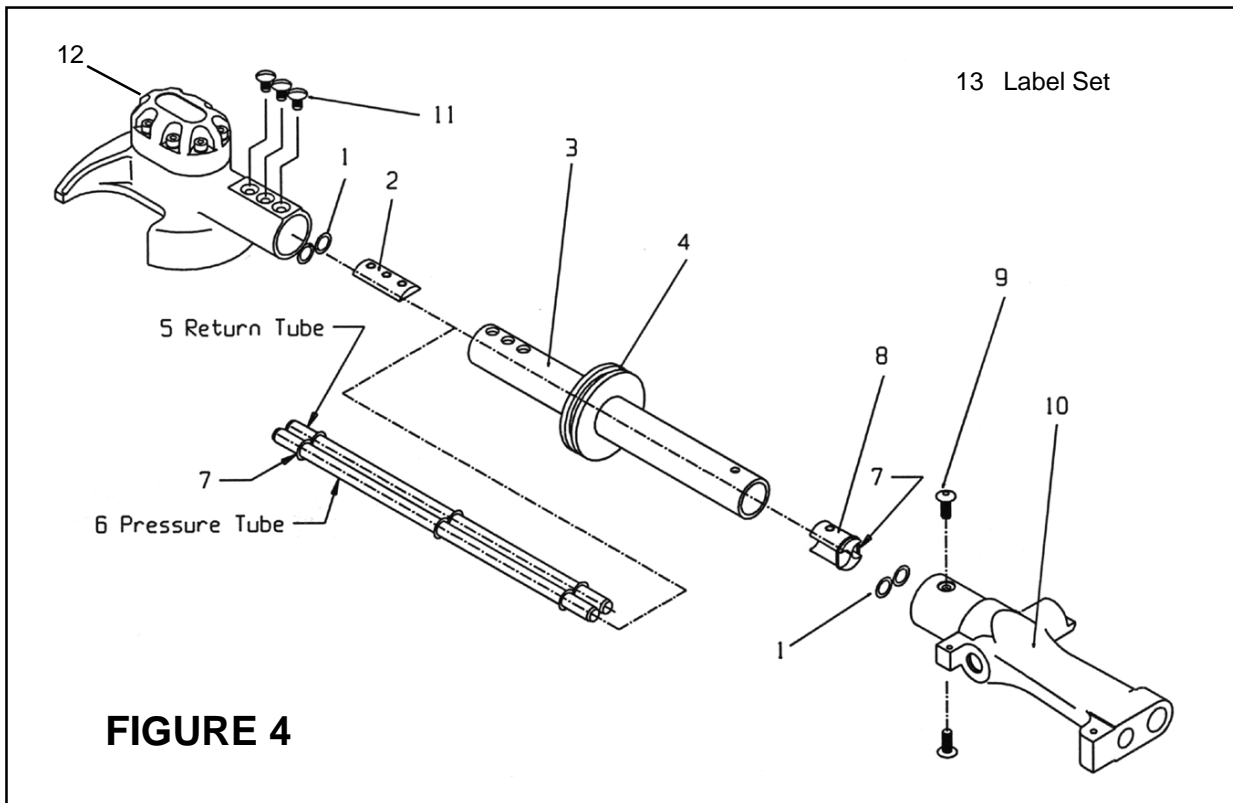

Key	Part No	Description	Qty.
1 *	13447	O-Ring, Internal	4
2	13415	Front Tube Support	1
3	*	Outer Tube	1
	13276S	For Model LR-88.5	
	13277S	For Model LR-75	
	13278S	For Model LR-62.5	
4	13422	Grommet	1
5	*	Return Tube	1
	13251	For Model LR-88.5	
	13452	For Model LR-75	
	13453S	For Model LR-62.5	
6	*	Pressure Tube	1
	13251P	For Model LR-88.5	
	13452P	For Model LR-75	
	13453P	For Model LR-62.5	
7 *	13425	Rubber Straps (O-Ring)	4
8	13416	Rear Tube Support	1
9	13448	Button Head Screw	2
10	13402	Control Handle	1
11	13440	Oval Head Screws	3
12	13403CM	Motor Assembly	1
13	RL13400	Label Set (Not Shown)	1

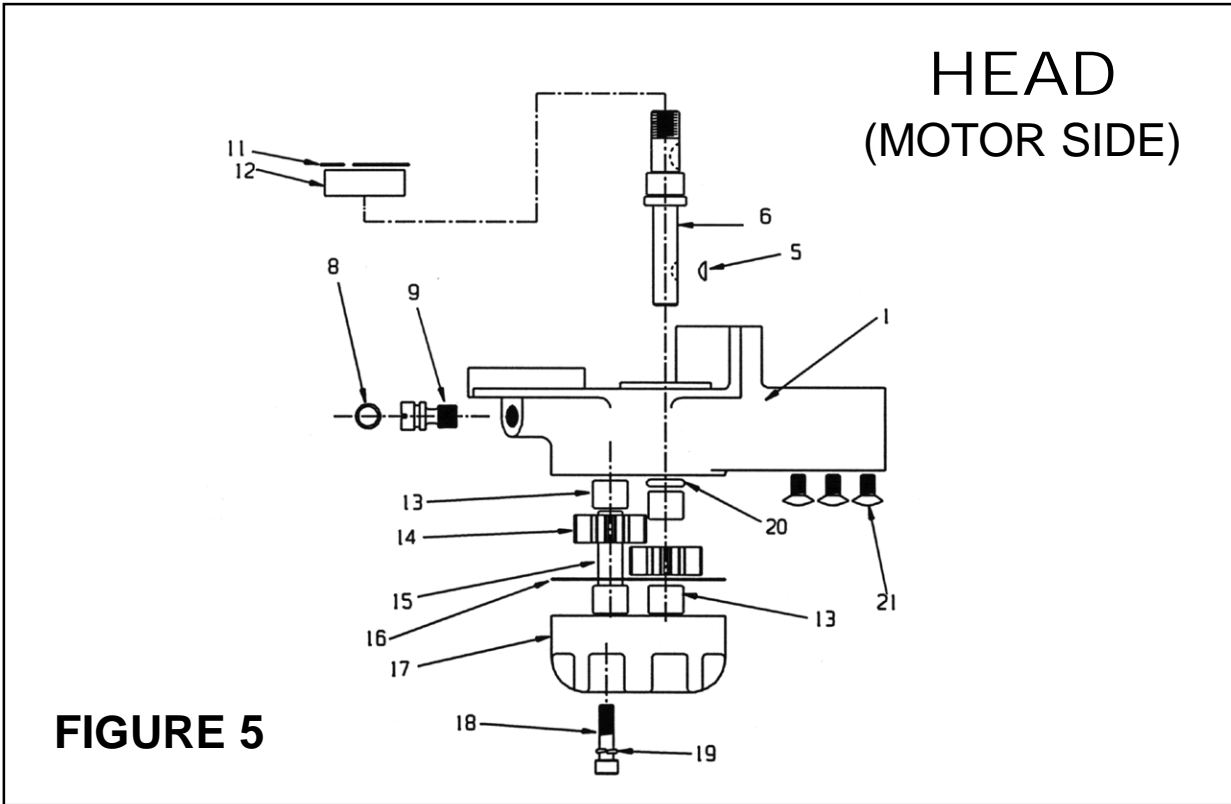

Item	Part No.	Description	Qty.
	<b>13403CM</b>	<b>Complete Motor Assembly</b>	<b>1</b>
1	13403	Motor Body	1
5	13427	Woodruff Key	1
6	13406	Drive Shaft	1
8 *	13413	O-Ring (Oiler)	1
9	13412	Lube Plug (Oiler)	1
11	13434	Snap Ring, Bearing Ret.	1
12	13411	Sealed Bearing	1
13	13435	Needle Bearing	4
14	13426	11 Tooth Gear	2
15	13407	Idler Shaft	1
16 *	13436	Gasket	1
17	13405	Motor Cap	1
18	13437	Socket Cap Screw	8
19	13438	Lock Washer	8
20 *	13439	O-Ring	1
21	13440	Oval Head Screws	3

# HEAD (CHAIN SIDE) PARTS LIST

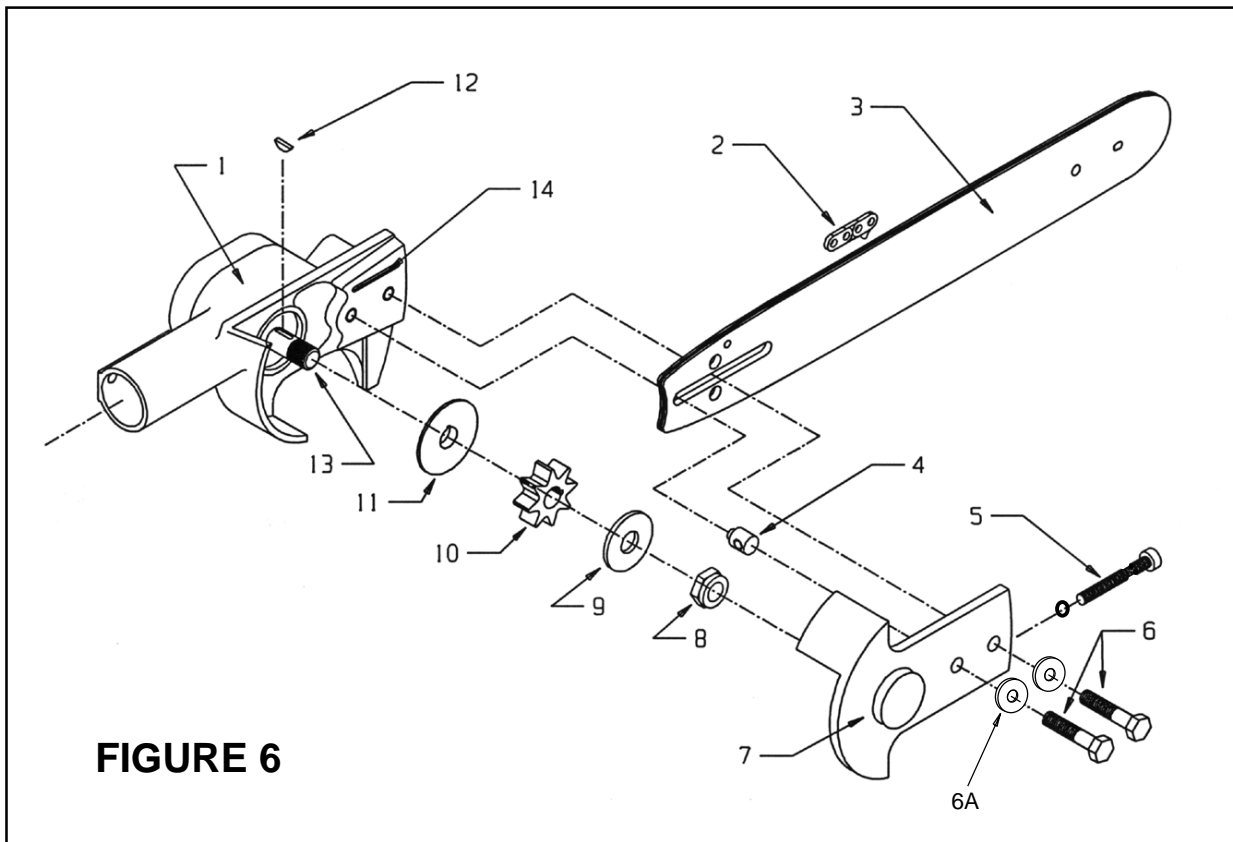

**FIGURE 6**

Item	Part No.	Description	Qty.
1	13403CM	Complete Motor Assembly	1
2	13453	Chain	1
3	13431	Chain Bar	1
4	13419	Chain Adjuster	1
5	13455	Adjusting Screw and Retainer	1
6	13456	Assembly Screws	2
6A	13449	Flat Washer	2
7	13418	Cover	1
8	13409	Jam Nut	1
9	13433	Flat Washer	1
10	13408	Sprocket	1
11	13457	Keyed Washer	1
12	13429	Drive Key, Sprocket	1
13	13406	Drive Shaft	1
14		Oil Groove	

# HANDLE PARTS LIST

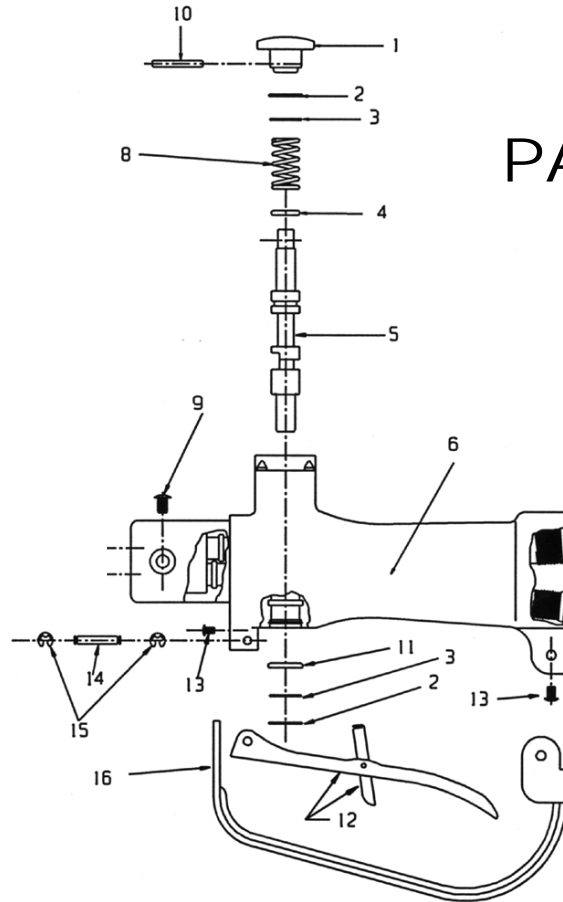

**FIGURE 7**

Item	Part No.	Description	Qty.
	<b>13402CH</b>	<b>COMPLETE HANDLE ASSEMBLY</b>	
1	13421	OC/CC Knob	1
2 *	13423	Snap Ring, Spool	2
3 *	13424	Spool Retainer Washer	2
4 *	13414	O-Ring, Back of Spool	1
5	13420	Spool	1
6	13402	Handle Body	1
8	13428	Spool Spring	1
9	13448	Screw, 1/4-20 x 3/4	2
10	13445	Spring Pin	1
11 *	13417	O-Ring, Front of Spool	1
12	13490	Trigger with safety	1
13	13441	10-32 Screw	3
14	13430	Trigger Pin	1
15	13457	Snap Ring	2
16	13432	Trigger Guard	1
	13446	Seal Kit - * Indicates items included in set	1

# DISASSEMBLY

## CHAIN AND MOTOR ASSEMBLY



### WARNING

Before any disassembly, disconnect hoses from the Chainsaw! Any residual pressure within the unit can and will spray at high velocity, injuring the person doing the disassembly. Hot or pressurized hydraulic fluid will cause serious injury to the body! Accidental movement of the chain can cause serious injury, dismemberment of a hand, finger or any other part of the body.

Complete disassembly is not recommended. Return the unit to an authorized dealer for total disassembly and/or repair.

All maintenance or disassembly should take place on a flat, clean work surface covered with towels or wipers so as to have a clean space for the disassembled parts.

Inspect each part during disassembly for wear, scratches, and cuts. Discard the worn or damaged parts and replace with new parts.

O-rings are sensitive to sharp edges. Inspect closely for cuts or damage. A small cut will cause a leak. When assembling or disassembling O-rings, use hydraulic fluid as a lubricant to help disassembly or installation.

# DISASSEMBLY

## MOTOR AND BLADE ASSEMBLY

Adjusting and installing saw chain is an ongoing task. Fig. 6 may be found on page 16.

**See Fig. 6** exploded view as a reference to explain this procedure. Start by removing two hex bolts (6) and pull off cover (7). This exposes the blade assembly for maintenance, adjustment, and replacement of the chain blade. Inspect and clean oil groove (14) to allow for correct chain lubrication. Remove saw chain (2), adjusting screw (5), chain adjuster (4), and chain bar (3). Remove lock nut (8). This allows for the removal of: (9), (10), (11) and (12) from drive shaft (13).

**See Fig. 5** for motor disassembly. Remove 8 screws (18) and lift motor cap (17) off. Remove motor gears (14), gasket (16) and idler shaft (15). Bearings (12) and (13) should not need to be removed unless extreme wear has occurred. Bearing replacement would be a factory function only.

Remove lubricator screw (9) and O-ring (8). This completes disassembly of the motor head, chain, and chain guide bar.

# VALVE/HANDLE DISASSEMBLY

**Refer to Figure 7, Page 18**

Remove the three button head screws (13) holding the trigger guard to the valve body. Remove one snap ring (15) from the pin (14), holding the trigger to the valve body, and remove pin. Before removing the control knob (1), mark the relative position to the spool (5). Remove pin (6) from spool (5). Remove retaining ring (2) and remove knob (1) from the spool (5). Remove washer (3) and spring (8). If there is a problem with the O-ring (11), remove the bottom retaining ring (2), the bottom washer and with an O-ring removal tool, remove O-ring (11) for inspection.

# TUBE DISASSEMBLY

**Refer to Figure 4, Page 15**

## **Removal of Tube Assembly from Valve**

Remove two screws (9) from valve body. Gently slide outer tube (3) from valve (10).

## **Removal of Tube Assembly from Motor Housing**

Remove three oval head screws (12) from motor housing. Gently slide outer tube (3) away from motor housing.

## **Removal of Inner Tubes (5 and 6) from Outer Tube (3).**

Push or pull inner tubes from the outer tube.

Three O-rings (7) have been twisted into a figure 8 and slid over the two-tube assembly to hold the two tubes together and in alignment. Make sure that they are aligned properly.

The inner tubes as depicted in Fig. 4 show the relative position of the pressure and return tube to the other components. Be sure that the inner tube assembly is in the position shown relative to the valve and the motor head.

# ASSEMBLE TUBES

**See Figure 4, Page 15**

Tie the two inner tubes together with the three O-rings (7) twisted in a figure 8 configuration. The pressure tube (6) is marked with blue ink on each end. The return tube (5) has no marking. As shown in Fig. 4, the pressure tube closest to the bottom of the page. The return tube is shown above the pressure tube. Tubes must be fitted into the Rear Tube Support (8) with the O-ring around its end (shown on the right.) The outer tube support can be inserted after placing it over the inner tubes and aligning it with the three holes in the head casting. Internal O-rings (1) should be replaced after disassembly. Remove and replace. Slide inner tubes (5 and 6) into their proper sockets with extreme care. The sockets can be seen in a cutaway section in Fig. 7. Be sure that the ends of the inner tubes are clean and free of burrs and tears so as not to cut or scratch the O-rings. Install the three oval head screws (11) and two button head screws (9).

# ASSEMBLE VALVE/HANDLE BODY

**See Figure 7, Page 18**

Install O-ring (11) in the groove near the bottom of the Spool Cavity, followed by Washer (3) and Retaining Ring (2).

Install O-ring (4) on Spool (5) being careful not to cut the ring when passing over sharp corners. Lubricate the Spool and slide it gently in the Valve Body. Install the Spring (8) followed by the Washer (3) and the Retaining Ring (2).

Install Knob (1) and Pin (6) in the Spool (5). Care must be taken to achieve the correct rotational position of the OC/CC markings in relation to certain features of the spool (5). There is a small flat on the spool where the Knob goes on. When this flat is facing up, the C on the back of the Knob (for closed center) is facing right.

Install the Trigger Assembly with the Pin (14) and the Snap Rings (15), followed by the Trigger Guard (16) using the Button Head Screws (13).

# PRODUCT UPDATE

See Figure 6, Page 17

In an effort to provide our customers with unbeatable customer support, updates will be sent out to inform you of product enhancements which may improve the performance of your tool from RELIABLE EQUIPMENT.

**TOOL:** LR SERIES - LONG REACH CHAINSAWS

**PROCEDURE:** STAKING

**PURPOSE:** This simple procedure will prevent the adjustment screw from loosening and possibly dropping out due to extensive vibration.

- DIRECTIONS:**
- 1 Remove chain cover from motor assembly.
  - 2 Center chain adjuster on chain adjusting screw.
  - 3 Advance adjusting screw fully.
  - 4 Align a centerpunch as close as possible to the exposed end of the bolt, and tap with a hammer spreading the thread. (*Refer to photo A below*)
  - 5 Turn the bolt 1/2 turn and repeat step 4.
  - 6 Re-assemble and adjust bar and chain as needed.

**NOTE:**  
Remember to follow safe work practices.

**A**



**B**



All future saw orders will feature a revised adjusting screw (**B**) with rubber lock-ring as well as staking. (*Shown at right*)



**CONTACT RELIABLE EQUIPMENT WITH ANY QUESTIONS REGARDING THIS UPDATE.**



# RELIABLE EQUIPMENT & SERVICE CO., INC.

## PRODUCT UPDATE

December 15<sup>th</sup>, 2004

**RELIABLE EQUIPMENT** is committed to continued customer satisfaction. As a result of this effort, product modifications and updates are made, to increase usability, enhance safety, or reduce repair cost and down time.

All new Long Reach Saws beginning with Serial # 4234 will feature a modified trigger assembly.

The new assembly features a modified Safety Latch, Spring, and Mounting Pin which will enhance the trigger performance, increase user safety, and reduce maintenance frequency.

Any saw requiring trigger parts or service will receive the new assembly.

Since all trigger assemblies shipped after the printing of this document will consist of the update product, the part number will not change. This should relieve identification issues or inventory change to our customers.

Please contact your  
Reliable Representative  
with any questions related  
to this Product Update

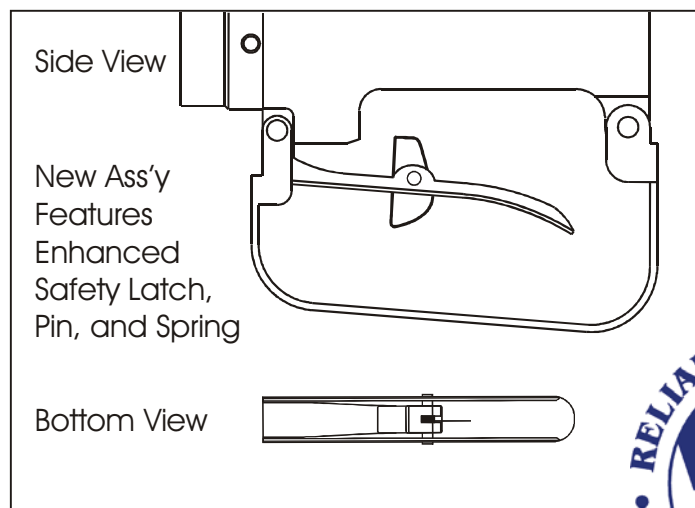



# PARTS ORDER FORM

# LONG REACH SAW LR-SERIES

COMPLETE SAW	Model	Description	Qty
★★★★★	LR-___	Long Reach Chain Saw	

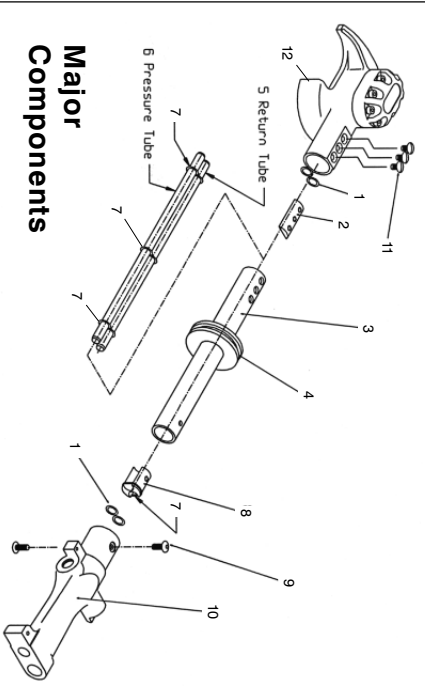

Key	Part No	Description	Qty.	Order
1 *	13447	O-Ring, Internal	4	
2	13415	Front Tube Support	1	
	13276S	LR-88.5		
3	13277S	Outer Tube	1	
	13278S	LR-75		
4	13422	Grommet	1	
	13251	LR-88.5		
5	13452	Return Tube	1	
	13453S	LR-75		
	13251P	LR-88.5		
6	13452P	Pressure Tube	1	
	13453P	LR-75		
7 *	13425	Rubber Straps (O-Ring)	4	
	13416	Rear Tube Support	1	
8	13448	Buton Head Screw	2	
9	13402	Handle Body	1	
10	13440	Oval Head Screws	3	
11	13403CM	Motor Assembly	1	
12	RL13400	Label Set	1	

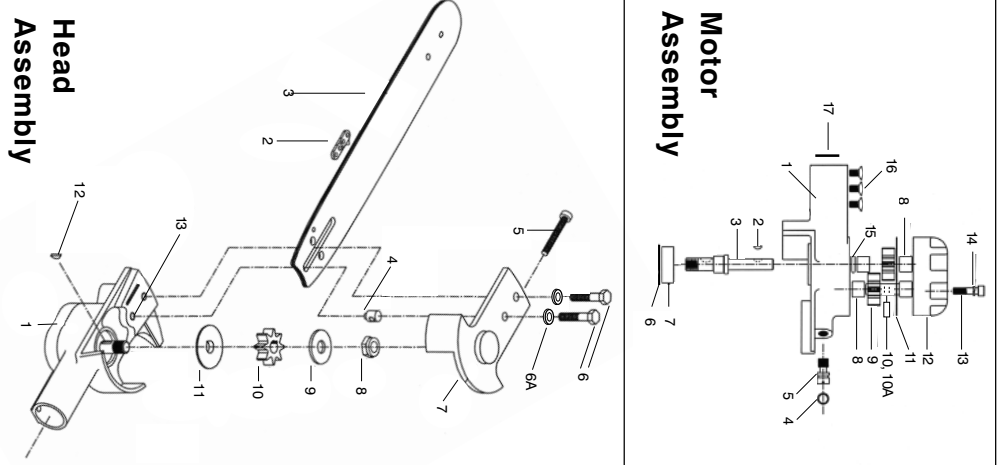

Key	Part No	Description	Qty.	Order
1	13403CM	Motor Assembly	1	
2	13403	Motor Body	1	
3	13427	Woodruff Key	1	
4	13406	Drive Shaft	1	
5 *	13413	O-Ring (Oiler)	1	
6	13412	Lube Plug (Oiler)	1	
7	13434	Snap Ring, Bearing Ret.	1	
8	13411	Sealed Bearing	4	
9	13435	Needle Bearing	1	
10	13426	11 Tooth Gear	2	
11	13407	Idler Shaft	1	
12	13141	Idler Shaft Pin	1	
13	13436	Gasket	1	
14	13405	Motor Cap W/ Bearings	1	
15	13437	Socket Cap Screw	8	
16	13438	Lock Washer	8	
17 *	13439	O-Ring	1	
18	13440	Oval Head Screws	3	
19	13447	O-Ring, Internal	2	

**RELIABLE EQUIPMENT & SERVICE CO., INC.**

Company: \_\_\_\_\_

P.O. #: \_\_\_\_\_ Release # \_\_\_\_\_ Date: \_\_\_\_\_

Crew #: \_\_\_\_\_ Authorized By: \_\_\_\_\_

Ship To: \_\_\_\_\_

Address: \_\_\_\_\_

City: \_\_\_\_\_ State: \_\_\_\_\_ Zip: \_\_\_\_\_

Phone #: \_\_\_\_\_

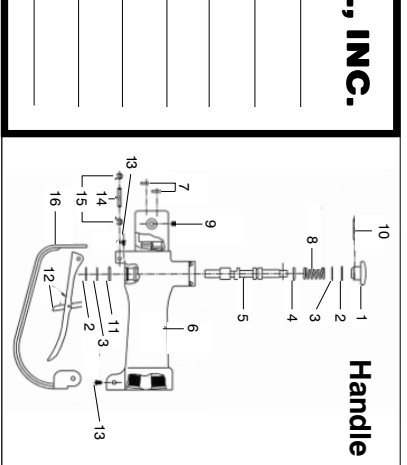

Key	Part No	Description	Qty.	Order
1	13402CH	Complete Handle Assy.	1	
2 *	13421	OC/CC Knob	2	
3 *	13423	Snap Ring	2	
4 *	13424	Spool Retainer Washer	2	
5	13414	O-Ring	1	
6	13420	Spool	1	
7 *	13402	Handle Body	1	
8	13447	O-Ring,	2	
9	13428	Spool Spring	1	
10	13448	Screw, 1/4-20 x 3/4	2	
11 *	13445	Spring Pin	1	
12	13417	O-Ring, Internal	1	
13	13490	Trigger with safety	1	
14	13441	10-32 Screw	3	
15	13430	Trigger Pin	1	
16	13457	Snap Ring	2	
	13432	Trigger Guard	1	
	13446	Seal Kit ( * Items included )		



92 Steamwhistle Drive • Ivyland, PA 18974

Phone: 800-966-3530 • Fax: 215-357-9193

Visit us on the web at [www.Reliable-Equip.com](http://www.Reliable-Equip.com)