

# OPERATORS' GUIDE

## REL-10-I

10,000 PSI INTENSIFIER



This revolutionary intensifier will increase line pressure to a maximum of 10,000 psi and is fully compatible with all high pressure hydraulic equipment. (i.e. Crimping, Cutting & Sparring Tools)

### NOTICE

Sizes, weights and tool specifications listed in this manual are subject to change without notice. Please consult factory for information and updates.

RELIABLE EQUIPMENT & SERVICE CO., INC.  
92 Steamwhistle Drive • Ivyland, PA 18974 • USA  
Phone: 215-357-3500 • Fax: 215-357-9193

MODEL: REL-10-I & REL-10-I-SA  
SOURCE PRESSURE: 2,000 PSI  
INTENSIFIED PRESSURE: 10,000 PSI  
SERIAL NO.: \_\_\_\_\_  
YEAR: \_\_\_\_\_



## REL-10-I-SA REL-10-I-SA/D

SINGLE & DOUBLE ACTING  
HYDRAULIC 10,000 PSI  
INTENSIFIER / VALVE

The **NEW** REL-10-I-SA/D single & double acting control systems provides a unique solution to your high pressure tooling requirements.

This system combines the power of a high pressure intensifier with the simplicity of a fixed position three way control valve.



### WARNING



All information found in this guide must be read and understood before operation or testing of this tool.

Failure to read and understand these warnings and safe handling instructions could result in severe personal injury and or death.

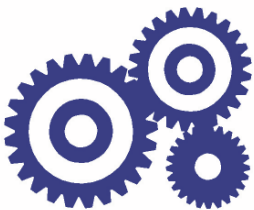

# RELIABLE EQUIPMENT & SERVICE CO., INC.

# DISTRIBUTED BY

---

## REGISTRATION

UPON RECEIPT OF THIS TOOL, COMPLETE THE REGISTRATION BELOW.

COMPANY \_\_\_\_\_

ADDRESS \_\_\_\_\_

\_\_\_\_\_

PHONE \_\_\_\_\_ FAX \_\_\_\_\_

SERIAL NUMBER \_\_\_\_\_

DATE OF PURCHASE \_\_\_\_\_

DEALER NAME \_\_\_\_\_

# TABLE OF CONTENTS

Registration & Distributor Information .....	2
Table of Contents.....	3
Tool Quick Reference (REL-10-I) .....	4
Tool Quick Reference (REL-10-I-SA).....	5
Tool Quick Reference (REL-10-I-SAD).....	6-7
General Safety Issues .....	8-10
Pre-Operation .....	11
Hydraulic Fluids .....	11
Connections and Hoses (ALL MODELS) .....	12
Operation (REL-10-I-SA).....	13
Operation (REL-10-I-SAD Single Acting).....	14
Operation (REL-10-I-SAD Double Acting) .....	15
<b>MAINTENANCE</b>	
General .....	16
Before Disassembly.....	17
REL-10-I Drawings & Parts Lists (Fig. 1 & 2) .....	18-19
REL-10-I Drawing & Parts List (Fig. 3).....	20
PVA-00L3 Control Valve Drawing & Parts List (Figure 4) .....	21
Maintenance Record.....	22
Manufacturer Contact Information (Phone, Fax & Address) .....	22



**THIS SYMBOL INDICATES ITEMS OF EXTREME IMPORTANCE.**

Safety of user and others may be in jeopardy if these instructions are not read and understood.



WARNING

Operation/Safety methods may vary in accordance with the working guidelines established by each utility or contractor

For your own safety, ensure that you fully comply with all safe operation guidelines required by your employer.

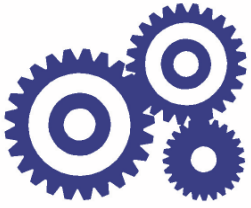

# RELIABLE EQUIPMENT & SERVICE CO., INC.

## REL-10-I INTENSIFIER 10,000 PSI



**Height** 4.50 in.  
**Length** 5.25 in.  
**Width** 4.25 in.  
**Weight** 9.75 lb.



### A SMALL TOOL FOR A BIG JOB!

This revolutionary intensifier will increase line pressure to a maximum of 10,000 psi and is fully compatible with all high pressure hydraulic equipment. (i.e. Crimping, Cutting & Sparring Tools)

In comparison to the Stage Pump's 75 to 185 moving parts, Reliable's Intensifier with only 12 moving parts will provide consistent, smooth operation and simplicity of service, which was never before available in it's costly and complex counterpart.

### SPECIAL FEATURES

1. H/P Quick-Disconnects
2. Folding Handle with 90° Stop
3. Adjustable Mounting Brackets

**REL - 4 - I** Increase to 4,000 psi  
**REL - 6 - I** Increase to 6,000 psi  
**REL - 10 - I** Increase to 10,000 psi

### SPECIFICATIONS

HYDRAULIC SYSTEM ..... Open or Closed Center  
MOTOR ..... Gear Driven  
OPERATING PRESSURE ..... 1,400-2,000 psi  
FLOW RANGE ..... 4-7 gpm  
OPTIMUM OPERATING PRESSURE .. 1,800 psi @ 6 gpm  
OUTPUT - FAST ADVANCE MODE ..... 305 in. <sup>3</sup>/min  
OUTPUT - HIGH PRESSURE MODE ..... 30 in. <sup>3</sup>/min  
RELIEF VALVE SETTING ..... 4,000 - 10,000 psi  
HIGH PRESSURE PORT ..... 3/8 in. NPT  
INLET PORT ..... 3/8 in. NPT  
RETURN PORT ..... 3/8 in. NPT

### SPECIAL FEATURES

HIGH PRESSURE COUPLER ..... Included  
ADJUSTABLE MOUNTING BRACKETS ..... Included  
UL-BCA - MOUNTING BUCKET ..... Optional



## RELIABLE EQUIPMENT & SERVICE CO., INC.

92 Steamwhistle Drive • Ivyland, PA 18974  
Phone: 800-966-3530 • Fax: 215-357-9193  
Visit us on the web at [www.Reliable-Equip.com](http://www.Reliable-Equip.com)

# REL-10-I-SA

## SINGLE ACTING 10,000 PSI INTENSIFIER/VALVE

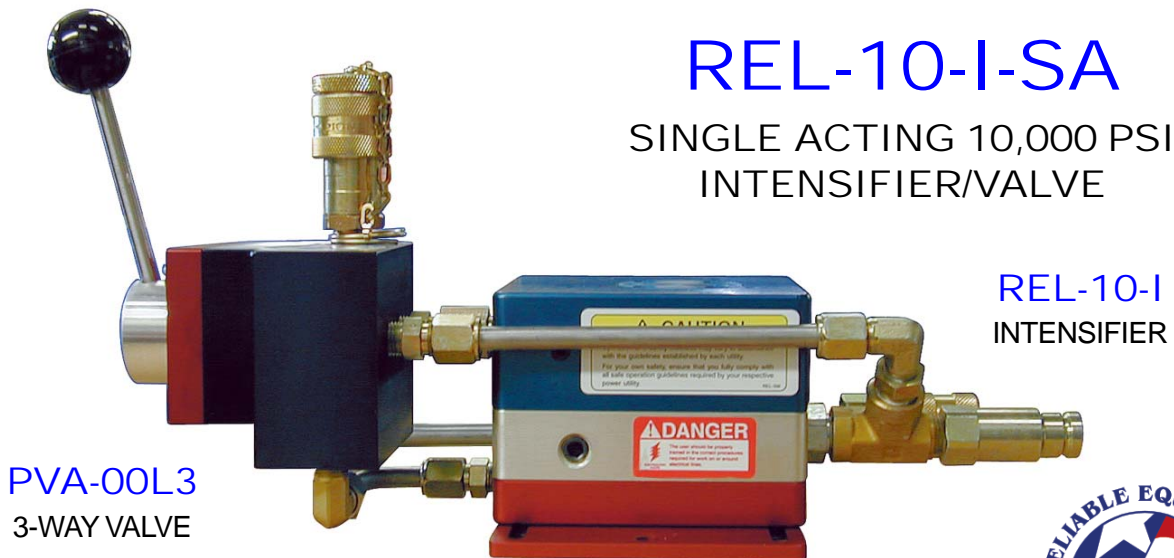

PVA-00L3  
3-WAY VALVE

REL-10-I  
INTENSIFIER

The REL-10-I-SA provides quick advance and retract for high pressure (10,000 psi) single acting spring return tools, without the need for additional H/P hoses, couplers or an in-line control valve.

This system combines the power of a high pressure intensifier with the simplicity of a fixed position three way control valve.

The REL-10-I intensifier will increase line pressure to a maximum of 10,000 psi and is fully compatible with all high pressure hydraulic equipment.

The PVA-00L3 single-acting control valve, provides 3-way control (Advance, Neutral, Retract) direct from the high pressure source. Together this intensifier/valve package allows return oil to bypass the intensifier and return directly to the tank (return) line, increasing tool speed and performance.

### SPECIFICATIONS

HYDRAULIC SYSTEM .....	Open or Closed Center
MOTOR .....	Gear Driven
OPERATING PRESSURE .....	1,400-2,000 psi
FLOW RANGE .....	4-7 gpm
OPTIMUM OPERATING PRESSURE ...	1,800 psi @ 6 gpm
OUTPUT - FAST ADVANCE MODE .....	305 in. <sup>3</sup> /min
OUTPUT - HIGH PRESSURE MODE .....	30 in. <sup>3</sup> /min
RELIEF VALVE SETTING .....	4,000 - 10,000 psi
HIGH PRESSURE PORT .....	3/8 in. NPT
INLET PORT .....	3/8 in. NPT
RETURN PORT .....	3/8 in. NPT

### SPECIAL FEATURES

HIGH PRESSURE COUPLER .....	Included
ADJUSTABLE MOUNTING BRACKETS .....	Included
UL-BCA - MOUNTING BUCKET .....	Optional

### SPECIFICATIONS - HYD. POWER SOURCE

200 PSI back pressure is the maximum agreed standard for the Hydraulic Tool Manufacturers Association (HTMA).

1. Maximum fluid temperature must not exceed 140°F (60°C) at the maximum expected ambient temperature. A sufficient oil cooling capacity is needed to limit the fluid temperature.
2. Maximum flow must not exceed 8 GPM. Install a flow meter in the return line to test the rate of flow in the system before working the tool.
3. Pressure relief valve must not exceed 2,200 PSI. The pressure relief valve must be located in the supply circuit between the pump and the intensifier to limit excessive pressure to the tool.

**Any hydraulic power source used with this unit must meet the requirements above.**

# RELIABLE EQUIPMENT COMBINES FORCE & FUNCTION

## REL-10-I-S/DA

### TYPICAL SINGLE ACTING SET-UP

(SHOWN ON THE RIGHT)

### TYPICAL DOUBLE ACTING SET-UP

(4-WAY VALVE REQUIRED)

(SHOWN BELOW)

REL-10-I-S/DA



REL-60SA  
S/A CRIMPING HEAD



3VE3  
10,000 PSI HOSE

3VE3  
10,000 PSI HOSE SET



REL-60DA  
D/A CRIMPING HEAD



REL-10-I-S/DA



PVA 1122  
CONTROL VALVE W/3VE3 HOSES

The **REL-10-I-S/DA** is the perfect 10,000 psi power source, providing all the benefits of a double acting tool system, while complementing existing single acting tool inventories.

Power, function, and simplicity have been combined into this unique all in one hydraulic power system.

This system combines the power of a high pressure intensifier with the simplicity of a fixed position three way control valve.

#### When using the single acting connection:

**REL-10-I-SA/D** provides quick advance and retract for high pressure (10,000 psi) single acting spring return tools, without the need for additional H/P hoses, couplers or an in-line control valve.

#### When using the double acting connection:

**REL-10-I-SA/D** provides quick advance and retract for high pressure (10,000 psi) double acting tools, combined with the versatility and efficiency of a four way control valve.

## SPECIFICATIONS

HYDRAULIC SYSTEM .....	Open or Closed Center
MOTOR .....	Gear Driven
OPERATING PRESSURE .....	1,400-2,000 psi
FLOW RANGE .....	4-7 gpm
OPTIMUM OPERATING PRESSURE ..	1,800 psi @ 6 gpm
OUTPUT - FAST ADVANCE MODE .....	305 in. <sup>3</sup> /min
OUTPUT - HIGH PRESSURE MODE .....	30 in. <sup>3</sup> /min
RELIEF VALVE SETTING .....	4,000 - 10,000 psi
S/A HIGH PRESSURE PORT .....	3/8 in. NPT
D/A HIGH PRESSURE PORT .....	1/4 in. NPT
LOW PRESSURE INLET PORT .....	3/8 in. NPT
LOW PRESSURE RETURN PORT .....	3/8 in. NPT

## SPECIAL FEATURES

HIGH PRESSURE COUPLERS .....	Included
ADJUSTABLE MOUNTING BRACKETS .....	Included
UL-BCA - MOUNTING BUCKET .....	Optional

# REL-10-I-S/DA

## SINGLE / DOUBLE ACTING HIGH PRESSURE CONTROL SYSTEM

(4-WAY CONTROL VALVE REQUIRED  
FOR D/A OPERATION)

## PVA-00L3 SINGLE-ACTING CONTROL VALVE

### DOUBLE ACTING HIGH PRESSURE CONNECTIONS

1/4" N.P.T.  
PRESSURE PORT  
FOR DOUBLE ACTING  
TOOL CONNECTION

1/4" N.P.T.  
RETURN PORT  
FOR DOUBLE ACTING  
TOOL CONNECTION

3/8" N.P.T.  
SINGLE ACTING  
HIGH PRESSURE  
CONNECTION

The REL-10-I intensifier will increase line pressure to a maximum of 10,000 psi and is fully compatible with all high pressure hydraulic equipment.

The PVA-00L3 single-acting control valve, provides 3-way control (Advance, Neutral, and Retract) direct from the high pressure source.

Together this intensifier/valve package allows return oil to bypass the intensifier and return directly to the tank (return) line, increasing tool speed and performance.

## REL-10-I INTENSIFIER

ADJUSTABLE  
MOUNTING BASE

LOW PRESSURE PORTS  
(TO POWER SUPPLY)

TANK  
3/8" M.N.P.T.

PRESSURE  
3/8" F.N.P.T.



## SPECIFICATIONS - HYD. POWER SOURCE

200 PSI back pressure is the maximum agreed standard for the Hydraulic Tool Manufacturers Association (HTMA).

1. Maximum fluid temperature must not exceed 140°F (60°C) at the maximum expected ambient temperature. A sufficient oil cooling capacity is needed to limit the fluid temperature.
2. Maximum flow must not exceed 8 GPM. Install a flow meter in the return line to test the rate of flow in the system before working the tool.
3. Pressure relief valve must not exceed 2,200 PSI. The pressure relief valve must be located in the supply circuit between the pump and the intensifier to limit excessive pressure to the tool.

**Any hydraulic power source used with this unit must meet the requirements above.**



**WARNING**

**BEFORE USING THIS TOOL, READ THE WARNINGS and the recommended practices described in this manual. Failure by the operator to read and fully understand these warnings will leave this person unqualified to use and operate this tool. Property damage, severe personal injury, and/or death could result by not following these warnings.**

These warnings will appear in appropriate locations when they are pertinent to the particular subject being shown. Read each one carefully and follow them strictly.



### **Eye Protection**

**WARNING**

**Always wear eye protection to avoid injury from flying debris or hydraulic oil leaks. Failure to do so can result in serious personal injury.**



### **Skin Irritation**

**WARNING**

**Hydraulic oil may cause irritation. Use care to prevent contact with skin. In case of accidental contact, wash affected area immediately**



### **Hard Hat**

**WARNING**

**Always wear a hard hat to avoid injury from falling debris. Failure to do so can result in serious personal injury.**



### **Foot Protection**

**WARNING**

**Always wear foot protection. Failure to do so can result in serious personal injury.**



### **Hearing Protection**

**WARNING**

**Always wear hearing protection, to avoid hearing loss due to long term exposure to high noise levels.**



### **Protective Gloves**

**WARNING**

**Always wear protective gloves Failure to do so can result in serious personal injury.**



WARNING

## Safe Operation & Care

**USE THIS TOOL FOR ITS INTENDED PURPOSE ONLY**  
Any other use can result in injury or property damage.  
**INSPECT TOOL BEFORE USE.** Replace any worn, damaged or missing parts. A damaged or improperly assembled tool may malfunction, injuring operator and/or nearby personnel.  
**INSPECT HYDRAULIC HOSES AND COUPLINGS** before each use. Repair or replace if any cracking, leakage, wear or damage is found. Worn or damaged hoses may fail resulting in personal injury or property damage.  
**CLEAR WORK AREA** of all bystanders and unnecessary personnel before operating this tool.  
**KEEP ALL PARTS OF THE BODY AWAY FROM MOVING PARTS.**  
Failure to observe this warning could result in serious injury.



WARNING

## Safety

**DO NOT** attempt to make any changes to any of the component parts or accessories when connected to the power source.  
**DO NOT** adjust, inspect, or clean tool while the tool is connected to the power source. The tool could accidentally start up and cause serious injury.  
**DO NOT** lock the tool in the On Position. In an emergency, serious damage or injury could occur during the time required to stop the tool.



WARNING

## Oil Injection Injury

Hydraulic oil or fluid under the skin is a serious injury. Oil under pressure can penetrate the skin and may cause dismemberment or loss of life. Seek medical assistance immediately if such an injury should occur.  
Always wear safety gloves, eye protection and all required safety equipment when operating or handling this tool.  
**DO NOT** use fingers or hands to attempt to locate a leak.  
**DO NOT** handle hoses or couplers while system is pressurized.  
**NEVER** open or service the system before depressurizing.



WARNING

## Burn Hazard

**Do Not connect or disconnect tool, hoses or fittings while power source is running or while hydraulic fluid is hot. Hot hydraulic fluid may cause serious burns.**

**Failure to observe this warning could result in serious injury.**



WARNING

## Electrical Shock Hazard

**Use only certified nonconductive hoses and fittings. Always wear and use the necessary clothing, equipment and safety practices to protect against electrical shock. Failure to follow these rules can result in serious personal injury or death.**



CAUTION

## Safe Handling

**HYDRAULIC FLUID MAY CAUSE SKIN IRRITATION.**

**Prevent hydraulic fluid from making contact with skin.**

**IN THE EVENT OF SKIN CONTACT immediately wash thoroughly.**

**Failure to observe this warning could result in injury.**



CAUTION

## General Safety

**Ensure that all fellow employees and bystanders are clear and protected from possible injury caused by this tool or the operations being performed. Persons in close proximity could be injured and property damaged if the tool were to malfunction.**

**This tool should always be used within the limits and purposes stated by the product manufacturer. Abuse or usage beyond the manufacturers' intended purposes could cause damage to the tool and severe injury to the operator.**



CAUTION

The information in this manual is intended to guide the user in the use and application of this tool. It is not intended as a substitute for proper training and experience in safe work practices for this type of equipment.

Consult your supervisor or safety personnel if you have any questions regarding the safe operation of this tool.

# PRE-OPERATION OF TOOL



WARNING

**DO NOT** connect hoses or fittings to pump before reading all of the instructions in this section.

Ensure power source is **OFF**, hydraulic flow is turned **OFF**.

Failure to comply with this warning can result in severe injury or death.

Before attempting to run or use the REL-10-I, REL-10-I-SA or connected tools, check all connections, including hoses, and couplings. (See WARNINGS on pages 4-7)

Wear all safety items required, and make sure that the working area is clear of obstructions and non-essential personnel.

## HYDRAULIC FLUIDS

All hydraulic fluids that meet these listed specifications or the listed HTMA specifications may be used for this tool.

### S. U. S.

@ 100° F (38° C) ..... 140 TO 225

@ 210° F (99° C) ..... 40 minimum

FLASH POINT ..... 340° F min. (170° C min.)

POUR POINT ..... -30° F min. (-34° C min.)



WARNING

## HOSES AND FITTINGS

There exists the potential for shock in using anything other than certified nonconductive hoses and hydraulic oil with dielectric properties, when using system components near energized electrical lines. Failure to recognize these conditions could cause electrocution.

Hoses and fittings used with this tool must comply with S.A.E. J1273 which covers recommended practice for selection, installation, and maintenance of hose and hose assemblies. The **correct hoses and fittings are available from your supplier.**

**WARNING:** Failure to comply with these warnings could result in severe bodily injury.

## NOTICE

If you have any questions regarding the information found in this manual please contact the supervising authority, or RELIABLE EQUIPMENT before continuing.  
Phone: 215-357-3500 Toll Free: 800-966-3530 Fax: 215-357-9193



WARNING

## UNIT/HOSE CONNECTIONS

**ALWAYS TURN OFF** hydraulic source and move valve handle to **RETRACT** before connecting or disconnecting any components.

**ALWAYS DEPRESSURIZE** hydraulic system, before slowly connecting/disconnecting this unit or any of the systems components.

**ALWAYS TIGHTEN** couplings completely. Loose or improperly tightened couplings will not allow fluid to pass through the hose creating a blockage in the supply or return line.

**ALWAYS INSPECT HOSES AND CONNECTORS** before connection to tool. Replace or repair if any leakage is evident. Leakage is a sign of deterioration in component parts. Worn or leaking parts must be repaired or replaced. Tool damage or severe injury could result.



CAUTION

## HOSE INSTALLATION

1. **ENSURE POWER SOURCE IS OFF AND OIL HAS COOLED,**
2. **ENSURE HYDRAULIC FLOW IS TURNED OFF.**
3. ALWAYS ENSURE CONNECTORS ARE CLEAN.
4. CONNECT HOSES TO HYDRAULIC SUPPLY.
5. ENSURE THAT THE VALVE IS IN THE RETRACT POSITION.
6. CONNECT THE REL-10-I-SA INTENSIFIER.
7. ENSURE THAT THE VALVE IS IN THE RETRACT POSITION.
8. CONNECT THE HOSE TO THE PRESSURE PORT ON THE REL-10-I-SA, THEN CONNECT TO THE PORT ON THE TOOL.



CAUTION

## DISCONNECTING HOSES

**Turn OFF hydraulic source, ensure valve handle is in the RETRACT position and oil has cooled before disconnecting the hydraulic source, tool, or hoses.**

Disconnect hose from the REL-10-I-SA, before disconnecting the tool. Disconnect the pressure hose from the pressure “P” port on the hydraulic source, then disconnect the hose from the pressure port on the REL-10-I-SA.

Disconnect the return hose from the return “T” port on the REL-10-I-SA, then disconnect the hose from the return (tank) port on the source.

Install dust caps on all connectors to prevent dirt and contaminants from entering the hydraulic system.

**WARNING:** Failure to comply with these warnings may result in severe bodily injury.

# REL-10-I-SA OPERATION

**USE ALL APPROPRIATE AND APPLICABLE PERSONAL SAFETY PROCEDURES AND EQUIPMENT AS REQUIRED BY THE OPERATING COMPANY.**

Inspect, set-up and connect the tool as described on the previous pages.

**WARNING: DO NOT** connect or disconnect the tool, hoses, or fittings while the tool is running, hot, or under pressure. **Serious injury or burns could result.**

Replace all parts that show signs of wear or damage.

A damaged or improperly assembled tool may injure operator and/or nearby personnel.

Set up desired operation. (ie. crimp, cut, or spearing).

Review and understand all operation and safety guidelines relating to the operation to be performed.

Ensure that valve is in the **RETRACT** position before initiating hydraulic power source.

Activate the **REL-10-I-SA** by moving valve handle to the **ADVANCE** position. *The tool operation will begin immediately.*

**NOTE:** Moving the valve handle to the **HOLD** (center) position will stop the tool action allowing for confirmation and repositioning as needed.

When relief valve popping occurs desired pressure has been achieved and operation should be complete.

Repeat as necessary.

**NOTE:** Holding valve handle in the **ADVANCE** position after relief valve has popped will cause unnecessary wear on relief valve and pump assembly.

Move valve to **RETRACT** and allow tool cutting blades, crimping jaws or ram to return fully.

Valve should be in the **RETRACT** position when not in use.

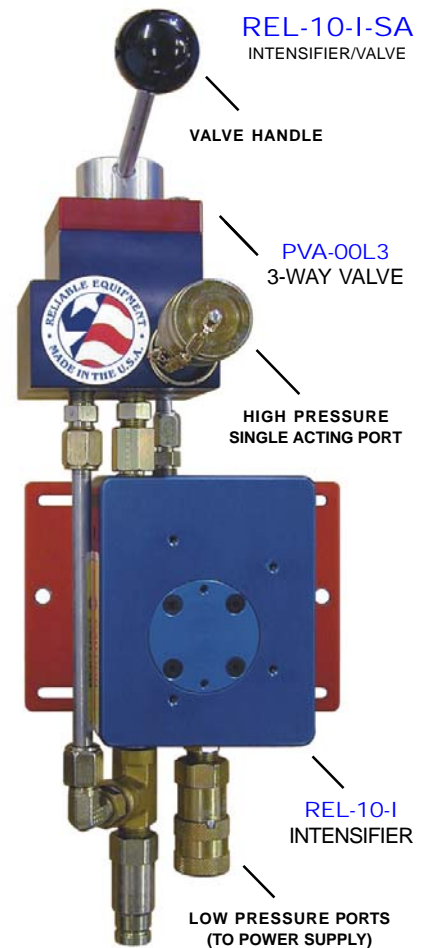

## NOTICE

If you have any questions regarding the information found in this manual please contact the supervising authority, or RELIABLE EQUIPMENT before continuing.

**Phone: 215-357-3500 Toll Free: 800-966-3530 Fax: 215-357-9193**

# REL-10-I-SAD S/A OPERATION

**USE ALL APPROPRIATE AND APPLICABLE PERSONAL SAFETY PROCEDURES AND EQUIPMENT AS REQUIRED BY THE OPERATING COMPANY.**

Inspect, set-up and connect the tool as described on the previous pages.

**WARNING: DO NOT** connect or disconnect the tool, hoses, or fittings while the tool is running, hot, or under pressure. **Serious injury or burns could result.**

Replace all parts that show signs of wear or damage.

A damaged or improperly assembled tool may injure operator and/or nearby personnel.

Set up desired operation. (ie. crimp, cut, or spearing).

Review and understand all operation and safety guidelines relating to the operation to be performed.

Ensure that valve is in the **RETRACT** position before initiating hydraulic power source.

Activate the **REL-10-I-SA** by moving valve handle to the **LEFT ADVANCE** position. *The tool operation will begin immediately.*

**NOTE:** Moving the valve handle to the **HOLD** (center) position will stop the tool action allowing for confirmation and repositioning as needed.

When relief valve popping occurs desired pressure has been achieved and operation should be complete.

Repeat as necessary.

**NOTE:** Holding valve handle in the **ADVANCE** position after relief valve has popped will cause unnecessary wear on relief valve and pump assembly.

Move valve to **RIGHT/RETRACT** and allow tool cutting blades, crimping jaws or ram to return fully.

Valve should be in the **RETRACT** position when not in use.

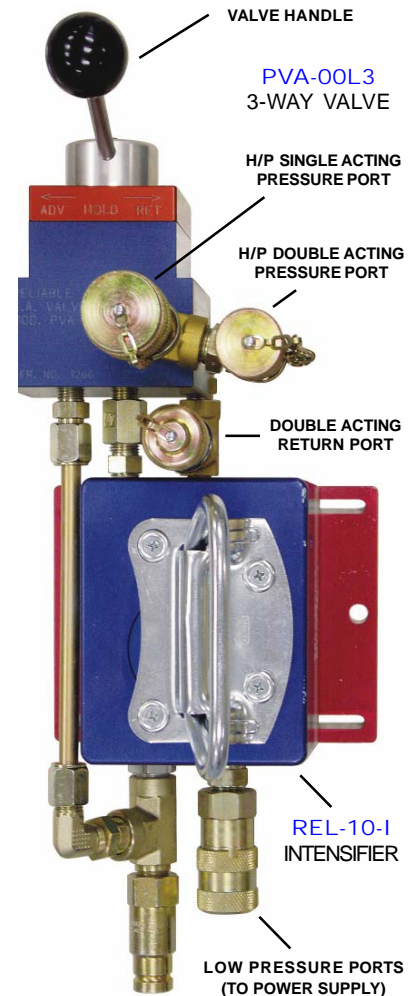

## NOTICE

If you have any questions regarding the information found in this manual please contact the supervising authority, or RELIABLE EQUIPMENT before continuing.

**Phone: 215-357-3500 Toll Free: 800-966-3530 Fax: 215-357-9193**

# REL-10-I-SAD D/A OPERATION

**USE ALL APPROPRIATE AND APPLICABLE PERSONAL SAFETY PROCEDURES AND EQUIPMENT AS REQUIRED BY THE OPERATING COMPANY.**

Inspect, set-up and connect the tool as described on the previous pages. **NOTE: AN IN LINE FOUR WAY CONTROL VALVE IS REQUIRED FOR DOUBLE ACTING OPERATION.**

**WARNING: DO NOT** connect or disconnect the tool, hoses, or fittings while the tool is running, hot, or under pressure.

**Tool damage, serious injury or burns may result.**

Replace all parts that show signs of wear or damage.

A damaged or improperly assembled tool may injure operator and/or nearby personnel.

Set up desired operation. (ie. crimp, cut, or sparring).

Review and understand all operation and safety guidelines relating to the operation to be performed.

Ensure that valve is in the **RETRACT** position before initiating hydraulic power source.

Activate the **REL-10-I-SA/D** by moving valve handle to the **LEFT/ADVANCE** position.

Operate in-line control valve to activate double acting tool and begin cutting or crimping procedure.

When relief valve popping occurs desired pressure has been achieved and operation should be complete.

**NOTE:** Holding control valve in the **ADVANCE** position after relief valve has popped will cause unnecessary wear on relief valve and pump assembly.

Use the in-line control valve to open or retract tool jaw/blades.

Repeat as necessary.

Move valve handle to **RIGHT/RETRACT** to stop pressure.

Valve should be in **RIGHT/RETRACT** position when not in use.

**WARNING: ALWAYS** ensure valve handle is in the retract position and hydraulic source is turned off before you connect or disconnect the tool, hoses, or fittings while the tool is running, hot, or under pressure.

**Serious property damage, injury, or burns may result.**

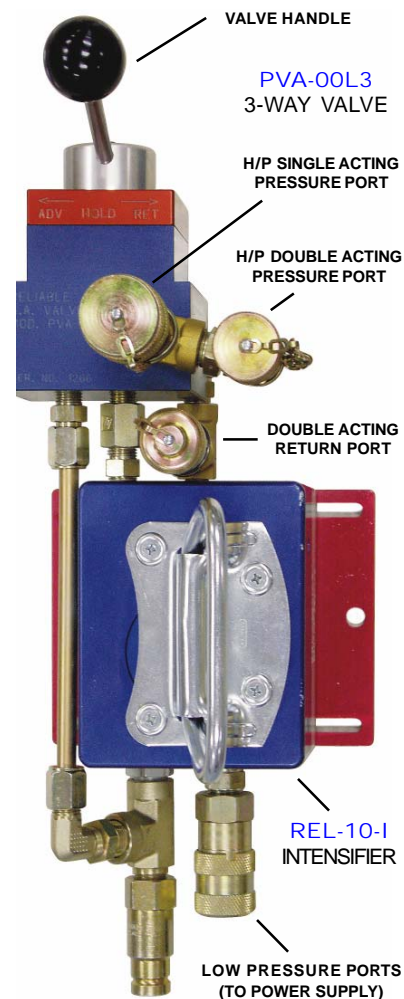

## NOTICE

If you have any questions regarding the information found in this manual please contact the supervising authority, or RELIABLE EQUIPMENT before continuing.

**Phone: 215-357-3500 Toll Free: 800-966-3530 Fax: 215-357-9193**

# SCHEDULED MAINTENANCE

The life, reliability, and safety of the tool is dependent on proper maintenance.

## DAILY MAINTENANCE

**Clean** all surfaces including, hand control, fittings, hoses and housing.

**Inspect** tool for wear and damage. Worn or damaged parts can cause malfunction.

**Inspect** for cracked hoses and leaking fittings.

**Check** fluid level of the power source reservoir frequently.

**All the above items must be replaced with new parts if signs of wear are evident.**

**FLUID CONTAMINATION:** Cover the ends of fittings with a dust cap when disconnected. This will help keep the fluid from contamination.



**IMPORTANT:** The greatest cause of hydraulic pump/valve failure is dirt. Prevent the introduction of foreign matter into the unit via hydraulic fluid, dirty connections or accumulation of sediment.

**MONTHLY MAINTENANCE:** Inspect per Appendix A, SAE Standard J1273, 5/86 for hose or fitting damage such as wear, cracks or leakage; replace the necessary parts.

NOTE: Keep Label Set clean and legible. Replace decals when necessary.



### WARNING

BEFORE USING THIS PRODUCT READ THE SAFETY WARNINGS and recommended practices described in the manual. Failure by the operator to read and fully understand the warnings will leave this person unqualified to use and operate the tool.

Failure to observe all warnings and instructions could result in property damage, severe personal injury, and/or death.

### CAUTION

Operation and safety methods may vary in accordance with the guidelines established by each utility. For your safety, ensure that you fully comply with all safe operation guidelines established by your respective power utility. REL-SM

### DANGER

The user should be properly trained in the correct procedures required for work on or around electrical lines.

# READ BEFORE DISASSEMBLY

**Complete disassembly is not recommended.**

Return the unit to an authorized dealer for total disassembly and/or repair.

All maintenance or disassembly should take place on a flat, clean work surface covered with towels or wipers so as to have a clean space for the disassembled parts.

Inspect each part during disassembly for wear, scratches, and cuts. Discard the worn or damaged parts and replace with new parts.

**Use only factory specified parts when repairing and/or replacing.**

**Severe damage to the tool can occur with non-specified parts.**

O-rings are sensitive to sharp edges. Inspect closely for cuts or damage. A small cut will cause a leak. When assembling or disassembling O-rings, use hydraulic fluid as a lubricant to help disassembly or installation.

The unique plumbing required to integrate the **REL-10-I** with the **PVA-00L3** 3-way valve is custom fitted for each unit, and cannot be purchased for non-factory repairs at this time. If any unit requires repair or replacement of these parts, please return to **RELIABLE** for factory authorized service.



WARNING

## Safety

**DO NOT attempt to make any changes to any of the component parts or accessories when connected to the power source.**

**DO NOT adjust, inspect, or clean tool while the tool is connected to the power source. The tool could accidentally start up and cause serious injury.**



WARNING

Before disassembly, disconnect hoses as described in this manual. Any residual pressure within the unit can and will spray at high velocity, injuring the person doing the disassembly. Hot or pressurized hydraulic fluid will cause serious injury or death.

**Complete disassembly is not recommended. Return the unit to an authorized dealer for total disassembly and/or repair.**

If you have any questions regarding the information found in this manual please contact the supervising authority or RELIABLE EQUIPMENT before continuing.

Phone: 215-357-3500 Toll Free: 800-966-3530 Fax: 215-357-9193

# REL-10-I INTENSIFIER DRAWING #1

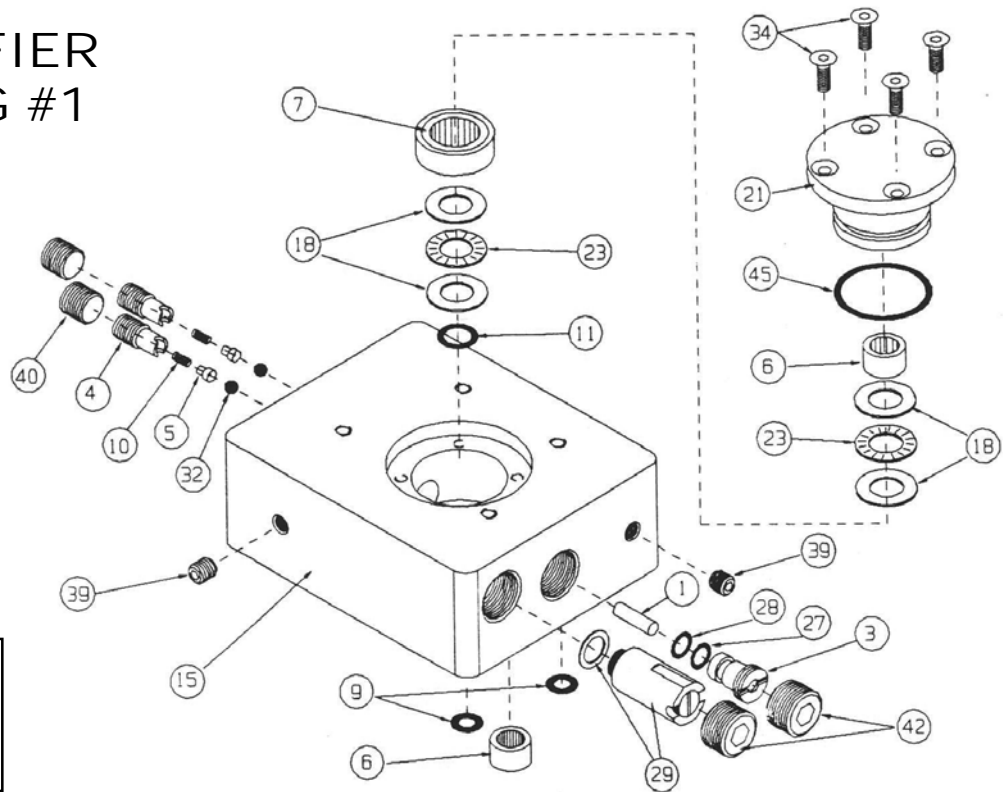

**Reference  
Parts List on  
Next Page**

# REL-10-I INTENSIFIER DRAWING #2

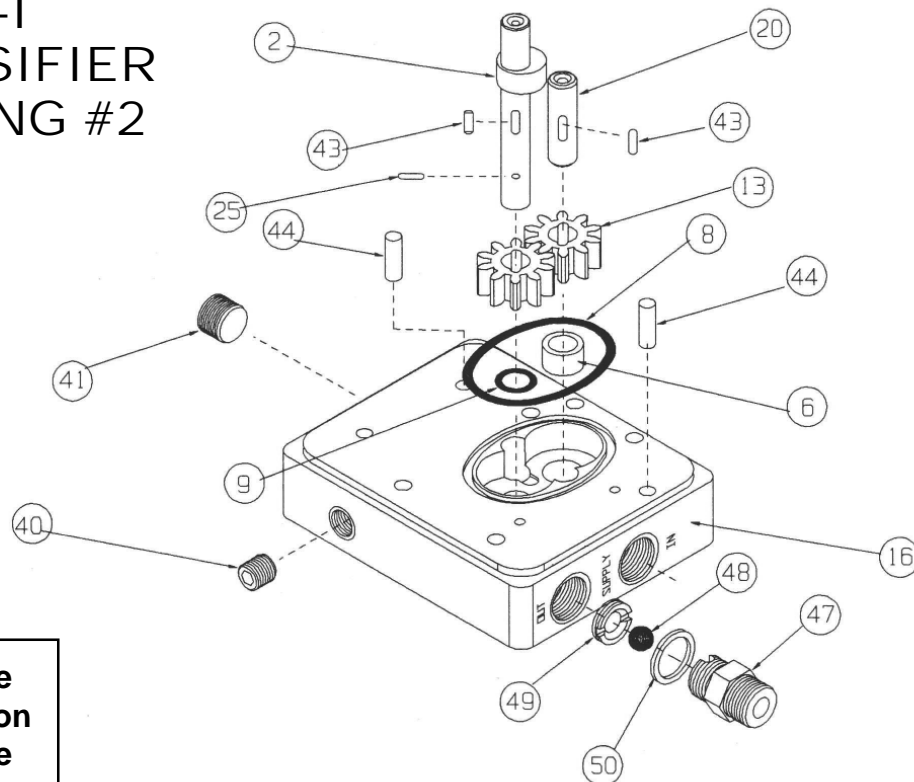

**Reference  
Parts List on  
Next Page**

## DRAWING #1 PARTS LIST

REF.	PART	QTY.	DESCRIPTION
* 1	12728	1	PISTON
* 3	12732	1	BUSHING (PRESSURE)
4	12733	2	CHECK VALVE BODY
5	12734	2	PINTLE
6	12736	6	SHAFT BEARING
7	12737	1	CAM BEARING ASSEMBLY
** 9	12739	3	O-RING HOLE SEAL
10	12740	2	SPRING (PINTLE)
** 11	12742	2	O-RING SHAFT SEAL
15	12766	1	PRESSURE BLOCK
18	12769	4	THRUST WASHER
21	12772	1	INSERT REAR
23	12774	2	BEARING (THRUST)
** 27	12778	1	BACK-UP RING
** 28	12779	1	O-RING BUSHING
29	12780	1	VALVE ASSEMBLY
32	12783	2	BALL (3/16")
34	12786	4	SCREW
39	12791	5	1/16 NPT PLUG
40	12792	1	1/4 NPT PLUG
42	12794	1	1/2 NPT PLUG
** 45	12741	1	O-RING REAR SEAL

## DRAWING #2 PARTS LIST

REF.	PART	QTY.	DESCRIPTION
2	12731	1	CAM SHAFT ASSEMBLY
6	12736	6	SHAFT BEARING
** 8	12738	2	O-RING FACE SEAL
** 9	12739	3	O-RING HOLE SEAL
13	12745	2	PUMP GEAR
16	12767	1	PUMP BLOCK
20	12771	1	SHAFT (IDLER, PUMP)
25	12776	2	PIN (DRIVE)
40	12792	3	1/4 NPT PLUG
43	12795	2	PINS (DRIVE)
44	12796	4	DOWELS
47	12735	1	REV. CHECK ADAPTER
48	12744	1	3/8 BALL
49	12743	1	BALL SEAT
** 50	12748	1	O-RING

\* TO BE SOLD AS A MATCH SET

\*\* SUPPLIED IN **SEAL KIT K3195** SAPRTLST 12/20/96

# REL-10-I INTENSIFIER DRAWING #3

Reference  
Parts List  
Below

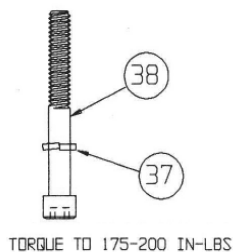

## DRAWING #3 PARTS LIST

REF.	PART	QTY.	DESCRIPTION
6	12736	6	SHAFT BEARING
** 8	12738	2	O-RING FACE SEAL
14	12746	2	RETURN GEAR (please advise serial # when ordering)
17	12768	1	PUMP GEAR (RETURN BLOCK)
22	12773	1	SHAFT (IDLER, RETURN)
30	12781	2	MOUNT
36	12788	4	SCREW (SCFH)
37	12789	6	SREW (SHCS)
38	12790	6	LOCKWASHER
43	12795	4	PINS (DRIVE)
44	12796	4	DOWELS

\*\* SUPPLIED IN **SEAL KIT K3195** SAPRTLST 12/20/96

If you have any questions regarding the information found in this manual please contact the supervising authority, or RELIABLE EQUIPMENT before continuing.  
Phone: 215-357-3500 Toll Free: 800-966-3530 Fax: 215-357-9193

PVA-00L3  
3-WAY VALVE  
DRAWING #4

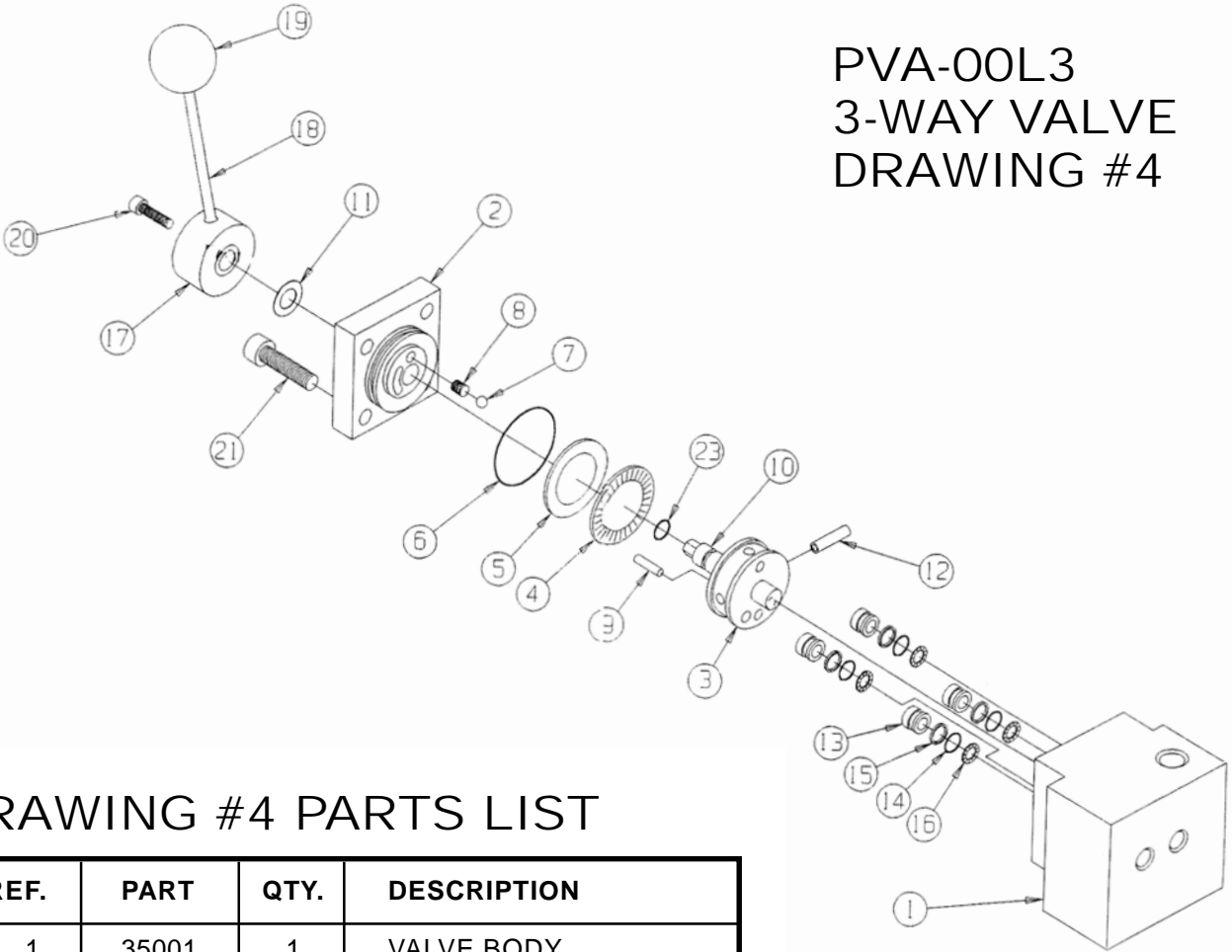

DRAWING #4 PARTS LIST

REF.	PART	QTY.	DESCRIPTION
1	35001	1	VALVE BODY
2	35002	1	CAP
3	35003	1	ROTOR
4	35004	1	THRUST BEARING
5	35005	1	THRUST WASHER
* 6	35006	1	O-RING (CAP)
7	35007	1	BALL, 1/4 DIA.
8	35008	1	SPRING
9	35009	1	ROLL PIN
10	35010	1	SHAFT
* 11	35011	1	GREASE SEAL
12	35012	1	SPIROL PIN
13	35013	4	GROMMET
* 14	35014	4	O-RING
* 15	35015	4	BACK UP RING
16	35016	4	CUST. WAVE SPRING
17	35017	1	ENDBLOCK
18	35018	1	STUD
19	35019	1	PLASTIC BALL
20	35020	1	SCREW (BHSC)
21	35021	4	SCREW (SHCS)
22	35022	2	PLUG (NOT SHOWN)
* 23	35022	1	SHAFT SEAL
* SUPPLIED IN SEAL KIT PART #R35100			

NOTICE

The unique plumbing required to integrate the **REL-10-I** with the **PVA-00L3** 3-way valve is custom fitted for each unit, and cannot be purchased for non-factory repairs at this time. If any unit requires repair or replacement of these parts, please return to **RELIABLE** for factory authorized service.

Consult your **RELIABLE** representative for more information about our complete line of hydraulic tools.

## MAINTENANCE RECORDS

Date	Parts or Service Required

If you have any questions regarding the information found in this manual please contact RELIABLE EQUIPMENT at the address, phone or fax numbers shown below.

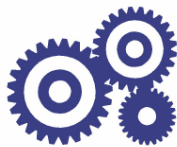

**RELIABLE EQUIPMENT  
& SERVICE CO., INC.**

92 Steamwhistle Drive • Ivyland, PA 18974

Phone: 800-966-3530 • Fax: 215-357-9193

Visit us on the web at [www.Reliable-Equip.com](http://www.Reliable-Equip.com)