

OPERATORS' GUIDE



REL-1500H - 3/4 TON
REL-3000H - 1-1/2 TON
LEVER OPERATED
ROLLER CHAIN HOIST

RELIABLE EQUIPMENT & SERVICE CO., INC.

92 Steamwhistle Drive • Ivyland, PA 18974 • USA
Phone: 215-357-3500 • Fax: 215-357-9193

MODEL: _____

SERIAL NO.: _____

YEAR: _____

WARNING



All information found in this guide must be read and understood before use or testing of this tool.

Failure to read and understand these warnings and safe handling instructions could result in severe personal injury and or death.

NOTICE

Sizes, weights and tool specifications listed in this manual are subject to change without notice. Please consult factory for information and updates.



**RELIABLE EQUIPMENT
& SERVICE CO., INC.**

DISTRIBUTED BY

REGISTRATION

UPON RECEIPT OF THIS TOOL, COMPLETE THE REGISTRATION BELOW.

COMPANY _____

ADDRESS _____

PHONE _____ FAX _____

SERIAL NUMBER _____

DATE OF PURCHASE _____

DEALER NAME _____



CAUTION

The information in this manual is intended to guide the user in the use and application of this tool. It is not intended as a substitute for proper training and experience in safe work practices for this type of equipment.

Consult your supervisor or safety personnel if you have any questions regarding the safe operation of this tool.

TABLE OF CONTENTS

DISTRIBUTOR INFORMATION	2
REGISTRATION	2
TABLE OF CONTENTS.....	3
TOOL SPECIFICATIONS	
REL-1500H & REL-3000H - ROLLER CHAIN HOIST	4
SAFETY INFORMATION AND WARNINGS	5-6
GENERAL MAINTENANCE	7
OPERATING INSTRUCTIONS	8-9
DAILY MAINTENANCE & LUBRICATION	10
INSPECTION CHECK LIST	11
PARTS DIAGRAM.....	12-13
PARTS LIST & TESTING	14-15
INSPECTION	16-18
DISASSEMBLY	19-21
ASSEMBLY	21-23
INSPECTION RECORDS	22
CONTACT INFORMATION	13

If you have any questions regarding the information found in this manual please contact RELIABLE EQUIPMENT at 800-966-3530 or FAX 215-357-9193.



THIS SYMBOL INDICATES ITEMS OF EXTREME IMPORTANCE.
Safety of user and others may be in jeopardy if these instructions are not read and understood.

NEW



Manufactured
to meet or exceed
ASME B30.21.



REL-1500H REL-3000H

MANUALLY LEVER OPERATED ROLLER CHAIN HOIST

These 2 **NEW** hoists from RELIABLE promise to provide years of service, under the rigorous conditions demanded by the Power Utility & Construction Industry.

The durable, malleable iron external frame and lever assemblies house internal components constructed and tested to provide smooth and safe operation.

FEATURES:

The lever action can be reversed simply by releasing the safety pin and rotating handle for inverted applications.

Safety hooks rotate 360° and feature spring latches to simplify a secure connection at the support and the load.

Thumb latch releases chain for easy connection.

Slack may be quickly removed by pulling on the free end of the chain.

Redundant safety measures prevent handle rotation or chain release under load if the operator were to lose control.

The **REL-1500H** has been manufactured to handle a 3/4 ton load with ease.

The **REL-3000H** utilizes a multiple chain configuration to offer a 1-1/2 ton capacity.

The chain lug hook may be detached to provide a longer lift capacity and faster operation in 3/4 ton applications.

Model	REL-1500H	REL-3000H
Capacity:	1,500 lbs.	3,000 lbs.
Travel:	56.5 inches	57 inches
Headroom:	13 inches	15 inches
Handle:	18.75 inches	18.75 inches
Stroke:	27 inches	27 inches
Weight:	18 lbs.	22 lbs.



92 Steamwhistle Drive • Ivyland, PA 18974
Phone: 800-966-3530 • Fax: 215-357-9193
Visit us on the web at www.Reliable-Equip.com



WARNING

BEFORE USING THIS TOOL, READ THE WARNINGS and the recommended practices described in this manual. Failure by the operator to read and fully understand these warnings will leave this person unqualified to use and operate this tool. Property damage, severe personal injury, and/or death could result by not following these warnings.

These warnings will appear in appropriate locations when they are pertinent to the particular subject being shown. Read each one carefully and follow them strictly.



Eye Protection

WARNING

Always wear eye protection to avoid injury from flying debris. Failure to do so may result in serious personal injury.



Skin Irritation

WARNING

Oil and lubricants may cause irritation. Use care to prevent contact with skin. In case of accidental contact, wash affected area immediately



Hard Hat

WARNING

Always wear a hard hat to avoid injury from falling debris. Failure to do so can result in serious personal injury.



Foot Protection

WARNING

Always wear foot protection. Failure to do so can result in serious personal injury.



Hearing Protection

WARNING

Always wear hearing protection, to avoid hearing loss due to long term exposure to high noise levels.



Protective Gloves

WARNING

Always wear protective gloves. Failure to do so can result in serious personal injury.



GENERAL SAFETY



DANGER

THIS UNIT IS NOT INTENDED FOR PERSONNEL LIFTING.

Overhead loads can fall.

Do not allow anyone to stand under or near load.

Maintain operator control at all times.

Failure to observe this warning could result in serious injury or death.

USE ALL APPROPRIATE AND APPLICABLE PERSONAL SAFETY EQUIPMENT as required by the operating company.

INSPECT TOOL BEFORE USE. Replace any worn, damaged or missing parts. A damaged or improperly assembled tool may injure operator and/or nearby personnel.

KEEP ALL PARTS OF THE BODY AWAY from moving parts of the tool.

MAKE SURE there is no person in close proximity to you, the tool, or the work area, who could be injured by any operation being performed, tool malfunction, or flying/falling debris.

DO NOT OVEREXTEND your position by overreaching or unbalancing the footing necessary to maintain physical control of your body and the tool.

ALWAYS MAINTAIN a firm grip on the tool to avoid loss of control during an operation, causing property damage, serious injury or death.

DO NOT PERFORM ADDITIONAL ACTIVITIES which divert attention from this operation.

USE THIS TOOL FOR THE MANUFACTURERS' INTENDED PURPOSE ONLY.

OBSERVE CLOSELY ALL OF THE SAFETY RULES FOR A PARTICULAR JOB CLASS

Operation/Safety methods may vary in accordance with the working guidelines established by each utility or contractor. Ensure that you fully comply with all safe operation guidelines required by your employer.



WARNING

ELECTRICAL SHOCK HAZARD

Always wear and use the necessary clothing, equipment and safety practices to protect against electrical shock.

Failure to observe this warning can result in serious injury or death.

**FAILURE TO HEED THESE WARNINGS COULD RESULT IN
PROPERTY DAMAGE, SERIOUS PERSONAL INJURY OR DEATH.**

GENERAL MAINTENANCE

It is recommended that a planned inspection routine be established.

Inspection intervals and procedures should be determined with respect to frequency and severity of use, as well as exposure to conditions that may cause wear or deterioration during use and storage.

An **Inspection Check List** can be found later in this manual.

Confirm operation of all components, and inspect each part for wear, cracks, bending and distortion.

Frequent Inspections should be performed daily to monthly by the trained operator or other designated person, and does not require a written report.

Under **NORMAL** usage and conditions the hoist should receive a monthly inspection.

Under **HEAVY** usage or adverse conditions the hoist should be inspected weekly to monthly.

Under **SEVERE** usage or extreme conditions the hoist should be inspected daily to weekly.

Periodic Inspections are in-depth in nature but DO NOT require complete disassembly. Some disassembly may be required to permit a more detailed inspection. A written test report is recommended and should be kept on file for later reference as needed.

Under **NORMAL** usage and conditions the hoist should receive a yearly inspection.

An evaluation by a designated person may indicate the hoist to require disassembly for a more detailed inspection.

Under **HEAVY** usage, a semiannual inspection may be required. An evaluation by a designated person may indicate the hoist to require disassembly for a more detailed inspection.

Under **SEVERE** usage, a quarterly inspection may be required. An evaluation by a designated person may indicate the hoist to require disassembly for a more detailed inspection.

Inspection of Hoists NOT in Regular Use:

For a hoist that has been unused for 1-5 months, refer to **Frequent Inspections** above.

For a hoist that has remained idle in excess of 6 months, refer to **Periodic Inspections** above.

Clean all parts thoroughly with an acid-free solvent. Roller chain should be soaked in solvent and agitated to ensure that all joints are free from foreign matter. Remaining deposits of dirt and grease may be removed using a stiff bristled brush dipped in the cleaning solvent.

WARNING: Read and follow all safety and handling instructions for cleaning solvents.

Lubrication - HOOKS: Allow a few drops of gear oil to run along shank into Frame Assembly.

SPROCKET SHAFT: Remove Lever Cap Screw and attach a grease gun forcing grease to bearing surfaces through lubrication passage.

SUPER SPROCKET PIN & BUSHING: Remove one Cotter Pin and unseat Sprocket Pin.

Apply a few drops of gear oil between Sprocket Pin and Bushing and work into assembly.

LOAD CHAIN: Lubricate entire chain with a penetrating oil containing graphite.

Work oil into each link and around Sprocket. Remove excess oil from Chain.

Refer to lubrication chart found on the next page and specific lubrication instructions for all parts as described in the **Assembly** section of this manual.

WARNING: Never apply grease to the chain.

All maintenance or disassembly should take place on a flat, clean work surface covered with towels or wipers so as to have a clean space for the disassembled parts.

Discard the worn or damaged parts and replace with new factory authorized parts.

When disposing of tool parts or components, observe all federal, state, and local guidelines.

PRE-OPERATION

This tool requires regular inspection and testing by qualified trained personnel.

Refer to Inspection criteria found later in this manual, and practices established by local authority.

Review acceptable safe practices, local usage and safety requirements.

Visual inspection of the hoist condition and operation, as well as the support structure, rigging and load are required. **DO NOT OPERATE A DAMAGED OR MALFUNCTIONING HOIST.**

NOTE: Stress caused by repetitive operation may reduce the integrity of support structure. Check hoist capacity and load. Overloading may damage hoist and cause personal injury or death.

OPERATION

Read entire manual prior to using this tool. Refer to all safety cautions and warnings.

This tool is to be used by qualified trained personnel only.

Observe all safe working practices as dictated by local codes and the operating authority. If you are unsure of these practices please obtain training for the required application.

1. Before beginning any operation, ensure that subject is within the capacity listed for the tool.

DO NOT OVERLOAD THE HOIST. Check the load. Use a larger capacity hoist if needed. Ensure that the hoist has been properly inspected and is in good operating condition.

2. Ensure that the slings and other rigging are in good condition and have sufficient capacity (at least equal to the combined weight of the hoist, and it's safe load rating) to support the load.

CLEAR THE AREA OF OBSTRUCTIONS to the load and the proper operation of the hoist.

Ensure that there is no person in close proximity to you, the tool, or the work area, who could be injured by any operation being performed, tool malfunction, or flying/falling debris.

3. **Secure the hoist to a suitable support device by use of the top hook.**

Ensure that the safety latch has closed completely and is operating properly..

NOTE: Failure to secure latch may compromise the security/safety of the load, resulting in severe damage and/or personal injury or death.

Apply a small amount of **Lubriplate** or equivalent between the hook and the support device.

4. Check and correct any twist or kink in the load chain prior to making a connection.

NEVER WRAP LOAD CHAIN AROUND THE LOAD.

Extend chain for easy connection of the hook. Turn side control lever to "Down" position, press thumb latch (release) on the lifting lever and pull chain as needed.

Attach the bottom hook to the load using a sling or other acceptable device.

DO NOT TIP LOAD THE HOOK. (hook strain and or failure may result)

Ensure that the sling or device is properly seated in the saddle, and the latch has closed completely and is operating properly.

DO NOT SIDE LOAD. Operation should be performed in a straight line between hooks. Side loading may cause damage to the hoist and compromise the safety of the load.

5a. TO RAISE OR PULL THE LOAD - Turn the side control to the “UP” position.

DO NOT OVEREXTEND YOUR POSITION by overreaching or unbalancing the footing necessary to maintain physical control of your body and the tool.

DO NOT STAND BENEATH THE LOAD or endanger any other persons while raising or moving the load.

Take up slack by pulling on the free end of the chain.

5b. TO LOWER OR REMOVE LOAD - Turn the side control to the “DOWN” position.

*** **NOTE:** See **SAFETY LOWERING** at the end of this section for additional instruction.

6. Extend the lifting lever upward completely. Raise, pull or lower load by operating the lever/handle down and repeat operation.



CAUTION: DO NOT RELEASE THE LEVER WHILE UNDER LOAD
The locking pawl will engage at the end of each lever stroke. The action should be notable and audible. If stroke cannot be completed, remain in control of the lever until it returns to the stop position on the load block frame.

RAISE OR PULL LOAD ONLY until the chain is taut. Inspect rigging before continuing.

DO NOT USE A HANDLE EXTENSION, CHEATER BAR OR ADDITIONAL PERSONNEL.

Additional force or leverage should not be required to operate your hoist within the rated working capacity. Check the hoist operation and load again.

Use a larger capacity hoist if needed.

7. Continue as described above to move the load as required by the operation.

DO NOT LEAVE THE HOIST UNDER LOAD unattended or for extended periods of time.

Additional precautions must be taken to ensure safety and provide protection.

Consult a qualified person for applicable safety practices related to your application.

*** **SAFETY LOWERING** - In lowering operations where the load counterbalances the lever an “unattended” ratcheting action may occur if the handle is released while under load.

This UNDESIRE occurrence can be prevented using the automatic safety feature.

It is recommended that this feature be employed for lowering operations. Immediately after turning the side control to the “DOWN” position return it to the “UP” position. The load can then be lowered using multiple short strokes.

NOTE: Keep the lever in the lower half of its normal operating range. Hoist action will revert to “UP” (RAISE/PULL) if lifting lever is extended fully.

OPTIONAL APPLICATIONS: _____

TO USE THE HOIST IN THE INVERTED POSITION. (UPSIDE DOWN)

Pull safety pin out as far as possible, and rotate lifting lever to the opposite side of the load block. The hoist will now operate on the down stroke with the hoist inverted.

CONVERSION OF MULTIPLE CHAIN HOIST TO THE NEXT SMALLER CAPACITY

Enables the hoist to perform longer lifts and/or faster operation. **(Model REL-3000)**

DAILY MAINTENANCE

The life, reliability, and safety of the tool is dependent on proper inspection & maintenance. Clean and inspect all surfaces (ie; hooks, latches, body, lever, chain, safety pin, etc...) Refer to the **Inspection Check List** found in this manual for items which require attention.

WARNING: Tool frame, handles and chain may cut or pinch. Please use extreme caution. Worn or damaged parts (i.e. bent handle or chain) may malfunction during operation, causing more extensive damage to the tool, load and/or severe injury to the operator or bystander.

All parts must be replaced with new parts if signs of wear or damage are evident.

Keep WARNING Labels clean and legible. DO NOT REMOVE Replace decals when necessary.

Observe during operation for any damage caused by or related to the applications in progress.

NOTE: Any unsatisfactory findings MUST be remedied before returning hoist to field operation.

WARNING

**READ
OPERATING
AND
MAINTENANCE
INSTRUCTIONS**

DO NOT: 1. USE WITH MORE THAN RATED LOAD. 2. LIFT PEOPLE OR LOADS OVER PEOPLE. 3. USE A HANDLE EXTENDER (CHEATER BAR). 4. USE IF DAMAGED OR MALFUNCTIONING. 5. SIDE-PULL HOIST. 6. USE WITH TWISTED KINKED OR DAMAGED CHAIN. 7. REMOVE OR OBSCURE THIS LABEL.

WARNING

RECOMMENDED LUBRICATION SCHEDULE

COMPONENT	TYPE OF LUBRICANT	TYPE & FREQUENCY OF SERVICE			
		HEAVY	NORMAL	INFREQUENT	
Load Chain	Penetrating Oil w/ graphite or SAE 20-30 gear oil	Daily	Weekly	Monthly	
Sprocket Shaft	Bearing Grease Multi Purpose - Lithium Base	Monthly	Yearly	Yearly	
Top Hook	SAE 20-30 Gear Oil	Monthly	Yearly	Yearly	
Bottom Hook		Weekly	Monthly	Yearly	
Super Sprocket Pin & Bushing		Monthly	Yearly	Yearly	
Locking Pawl		Service at Periodic Inspection			
Reverse Ring Stop Pin Rocker Arm & R.A. Shaft-Pin Assy R.A Center Post, Reverse Cam					
Reversing Ring - Shoulder Pin Assy.					
Internal lever Parts	Bearing Grease Calcium Base w/ Graphite				
This Lubrication Schedule is based on a hoist operating under NORMAL conditions. Operation under adverse conditions (i.e. dust, extreme heat, corrosive environments) may require more frequent Lubrication.					

IF YOU HAVE QUESTIONS REGARDING THE REPAIR AND MAINTENANCE OF THIS TOOL, CONTACT RELIABLE EQUIPMENT AT 800-966-3530

LEVER OPERATED CHAIN HOIST

INSPECTION & MAINTENANCE CHECK LIST

MANUFACTURED BY: RELIABLE EQUIPMENT & SERVICE CO., INC.
 MODEL # REL-1500H CAPACITY 1,500 LBS SINGLE CHAIN - ROLLER TYPE
 MODEL # REL-3000H CAPACITY 3,000 LBS DOUBLE CHAIN - ROLLER TYPE
 SERIAL # _____ ENTERED SERVICE ON ____/____/____ CREW # _____

Subject of Inspection	Conditions requiring additional inspection or repair	Frequency of Inspection			OK	Service Required
		Frequent Daily	Periodic Monthly	Periodic Yearly		
All functional mechanisms Lever, Control Lever, Thumb Latch	Improper Operation, Binding, or Unusual Sounds	●	●	●		
Load Chain	Inadequate lubrication, excessive wear, damage, or distortion, cracked, spread or twisted links, corrosion or obstruction	●	●	●		
Hooks	Stretched throat opening, Distortion, damaged hook latch, wear, chemical or environmental damage, worn hook bearing. Cracks Use dye penetrant, magnetic particle Magnaflux, or other suitable detection method	●	●	● ●		
Lever Parts: Lever Trip Rod Pawl, Trip Pin Release Spring and Pawl Spring Bushing	Bends, cracks, distortion Straightness, ability to move pawl Wear, binding Bends, excessive wear Deformation, breaks, corrosion Excessive wear, scoring	● ●	● ●	● ●		
Sprocket, Sprocket Shaft, Chain Attachments	Distortion, cracks, damaged teeth, damaged, Stripped threads			●		
Reverse Ring Shoulder Pin Assembly	Excessive wear, loose or missing pins			●		
Frames, Swivels	Cracks, distortion, excessive wear			●		
Locking Pawl	Excessive wear, binding			●		
Reverse Springs, Locking Pawl Springs	Deformation, breaks, corrosion			●		
Pins, Bolts, Rivets	Looseness, thread damage, corrosion			●		
Warning Label	Missing, damaged, or illegible			●		

NOTE: Refer to Maintenance and Inspection Sections of the Hoist Maintenance Manual for additional details.

For additional information regarding frequency of inspection, see General Maintenance.

REL-1500H 3/4 TON & RE

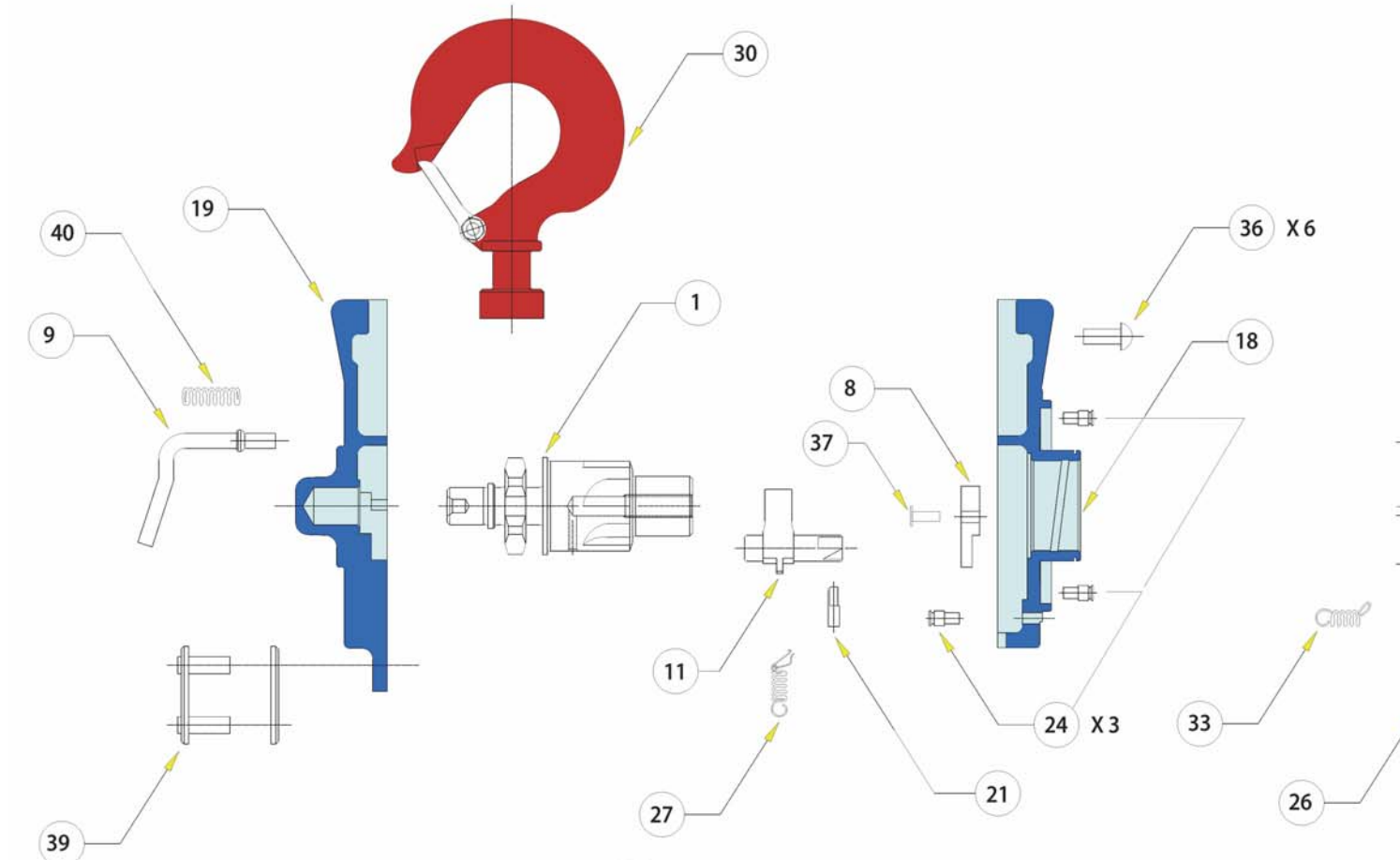

REL-3000H
1-1/2 TON
ONLY

LOAD BLOCK
ASSEMBLY FOR
3/4 TON HOIST

CHAIN LENGTH
3/4 TON - 5 FT.

LOAD BLOCK
ASSEMBLY FOR
1-1/2 TON HOIST

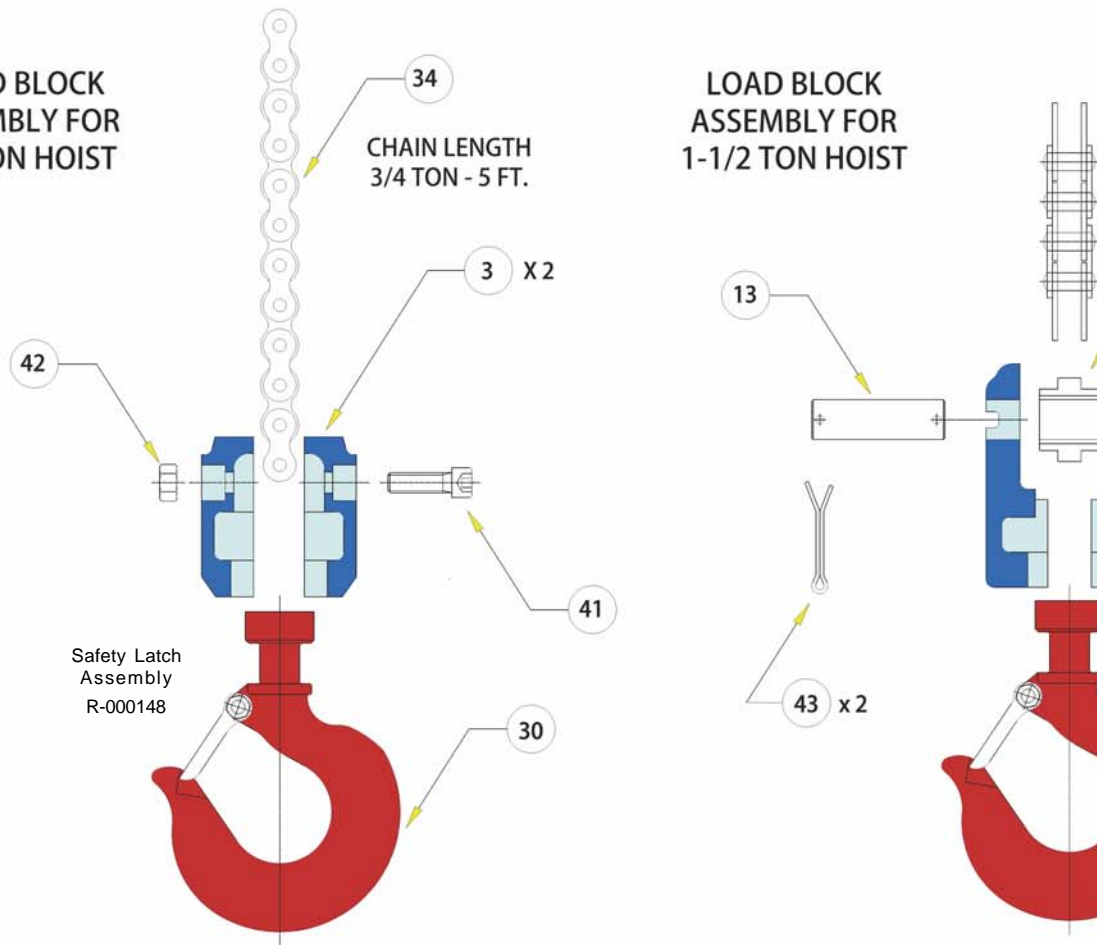

Safety Latch
Assembly
R-000148

REL-3000H 1-1/2 TON HOIST

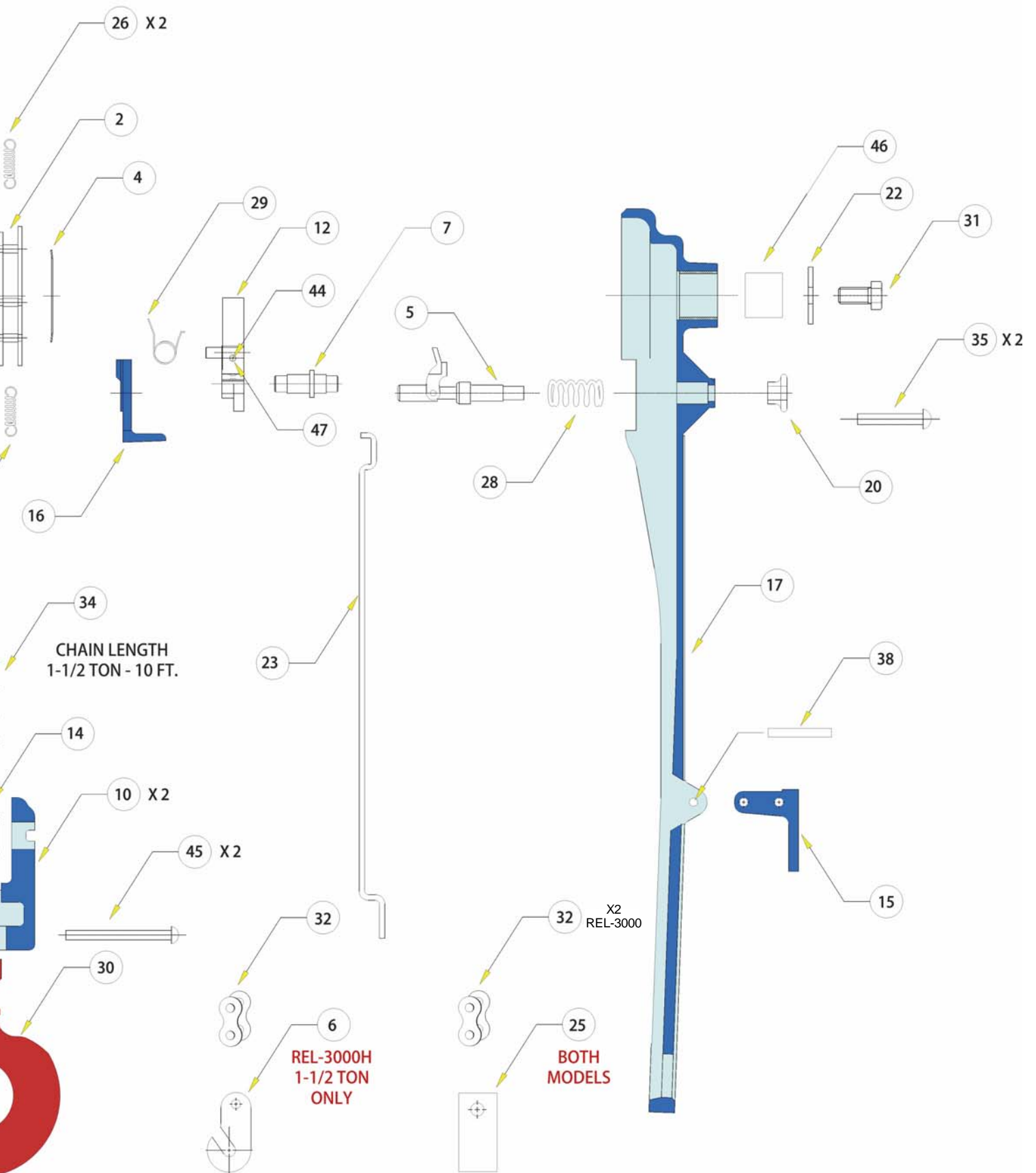

REL-1500H 3/4 TON & REL-3000H 1-1/2 TON HOIST

ITEM	DRAWING NUMBER	QTY	DESCRIPTION
1	R-000101	1	SPROCKET SHAFT
2	R-000102	1	REVERSING RING ASSEMBLY
3	R-000103	2	SWIVEL FRAME
4	R-000104	1	RETAINING RING
5	R-000105	1	SAFETY PIN ASSEMBLY
6	R-000106	1	CHAIN LUG HOOK 3000H 1-1/2 TON ONLY
7	R-000107	1	LEVER PAWL PIN
8	R-000108	1	CHAIN SHEDDER
9	R-000109	1	REVERSING LEVER
10	R-000110	2	SUPER FRAME
11	R-000111	1	LOCKING PAWL
12	R-000112	1	LEVER PAWL ASSEMBLY
13	R-000113	1	SUPER SPROCKET PIN
14	R-000114	1	SUPER SPROCKET ASSEMBLY
15	R-000115	1	THUMB LATCH
16	R-000116	1	LEVER PAWL COVER
17	R-000117	1	LEVER
18	R-000118	1	RIGHT FRAME
19	R-000119	1	LEFT FRAME
20	R-000120	1	SAFETY PIN KNOB
21	R-000121	1	LOCKING PAWL RELEASE PIN
22	R-000122	1	LEVER WASHER
23	R-000123	1	TRIP ROD
24	R-000124	3	STATIONARY PIN
25	R-000125	1	CHAIN END LUG
26	R-000126	2	REVERSE RING SPRING
27	R-000127	1	LOCKING PAWL SPRING
28	R-000128	1	SAFETY PIN SPRING
29	R-000129	1	LEVER PAWL SPRING

30	R-000130	2	HOOK (Safety Latch Assembly R-000148)
31	R-000131	1	LEVER CAP SCREW
32	R-000132	1 or 2	CONNECTING LINK ASSEMBLY (1) REL-1500H (2) REL-3000H
33	R-000133	1	LOCKING PAWL SPRING
34	R-000134	1	CHAIN (3/4 X 5') (1-1/2 X 10')
35	R-000135	2	ROUND HEAD RIVET .250 DIA X 1.50 LONG
36	R-000136	6	ROUND HEAD RIVET .250 DIA X .62 LONG
37	R-000137	1	TINNERS RIVET .190 DIA X .50 LONG
38	R-000138	1	ROLL PIN .187 DIA X .75 LONG
39	R-000139	1	CONNECTING LINK ASSEMBLY 3000H 1-1/2 TON ONLY
40	R-000140	1	REVERSE LEVER SPRING
41	R-000141	1	SOCKET HEAD CAP SCREW 5/16-24 UNC X 1.25 LONG
42	R-000142	1	HEX NUT 5/16-24 UNC PLATED HEX NUT
43	R-000143	2	COTTER PIN, EXTENDED MITER END 1/8 DIA X 1.00 LONG
44	R-000144	1	SOLID RIVET (LEVER PAUL)
45	R-000145	2	PULLING HOOK RIVET
46	R-000146	1	LEVER BUSHING
47	R-000147	1	LEAF SPRING

Test hoist upon completion of any disassembly or maintenance.

Testing should be performed by a trained, designated service technician. Observe the operation of the hoist through several NO LOAD operating cycles. Ensure that slack chain can be taken up by pulling on free end of chain. Turn the control lever to the DOWN position, push thumb latch and ensure that free chain can be obtained by pulling on lower hook.

Attach a nominal load (approximately 50-100 lbs.) to the hook and observe the operation of the hoist through several lifting and lowering cycles. If operation appears smooth and unrestricted, test hoist with rated load. Test the **REL-1500H** at 1,500 lbs.

Test the **REL-3000H** at 3,000 lbs.

Hoist must perform smoothly in both raising and lowering operations. If hoist fails to perform smoothly, proceed with required steps of Frequent, and Periodic Inspections as needed to resolve any operational issues before returning hoist to use in any application.

Inspection, Disassembly and Repair

All maintenance or disassembly should take place on a flat, clean work surface covered with towels or wipers so as to have a clean space for any disassembled parts.

Inspect each part for wear, cracks, bending and distortion. Discard worn or damaged parts and replace with new factory authorized parts.

Clean and lubricate all parts and assemblies during inspection, and before disassembly.

Dirt is among the leading causes of hoist failure.

FREQUENT INSPECTION

Inspect the hooks for environmental or chemical damage, cracks or distortion. (Twist in excess of 10° or throat openings in excess of 1-1/4 inch) DO NOT include Latch Assembly when measuring

NOTE: If hooks show signs of distortion due to overloading or abuse inspect all load bearing hoist components.

Ensure that both hooks swivel freely.

Inspect operation of Safety Latch Assemblies.

Inspect assemblies and observe operation of all control mechanisms.

Reversing Lever	Thumb Latch
Lifting Lever	Safety Pin

Inspect Load Chain Assembly and Operation.

NOTE: Clean and lubricate chain before inspection. Test lifting and lowering operations under nominal load (50 -100 lbs.) while observing chain and sprocket function.

Chain feed and stripping operations should be smooth and should not bind or jump.

NOTE: Observe audible cues (i.e., strain, popping) Check chain for elongation. (under nominal load) Measure a 16 pitch section that normally travels over the load sprocket using a caliper type gage. Measure from the edge of one chain pin to the edge of the 16th chain pin. (3/4 in. (19mm) pitch) This measurement should be 12 inches.

Chain has been compromised and should be replaced if measurement exceeds 12.25 inches.

Check chain for twist in excess of 15 degrees over any 5 foot section (extended & under nominal load)

Check chain for straightness or side bow in excess of .125 inch (1/8") over any 2.5 foot section of chain. (extended & under nominal load)

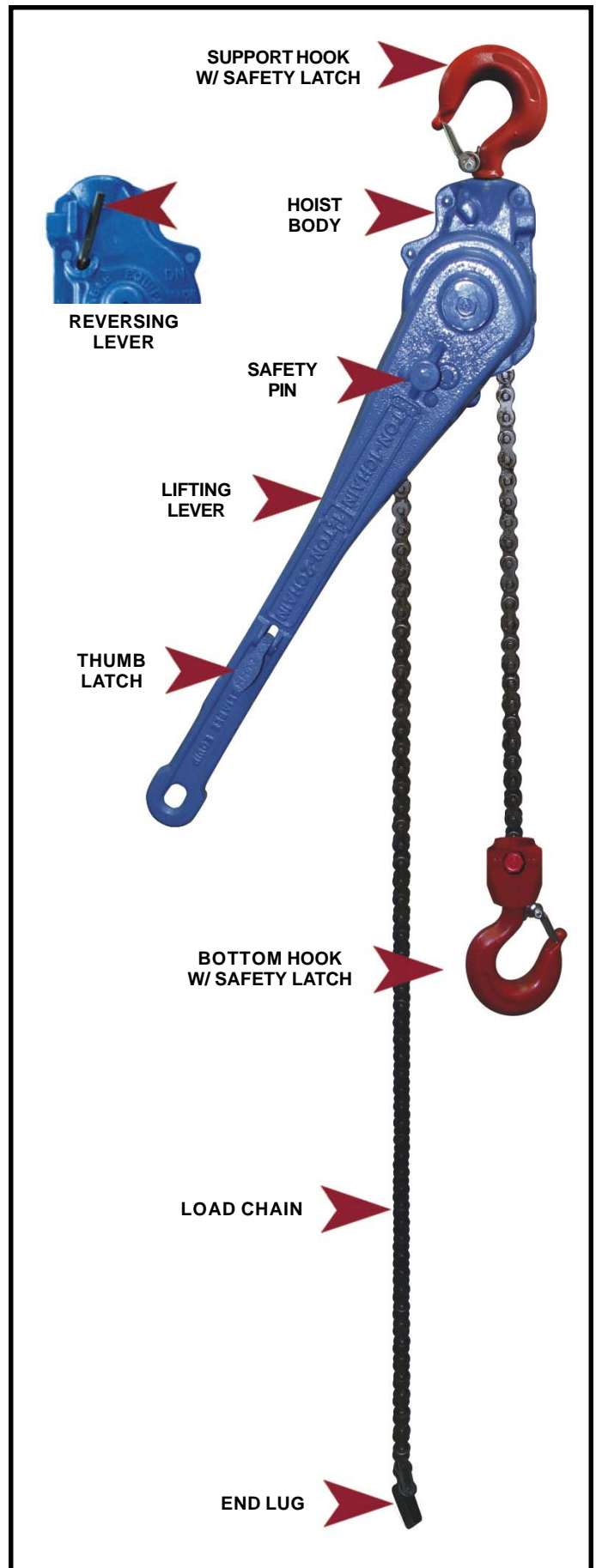

Additional inspection of chain (chain removed)
Remove End Lug (REL-1500H) End Lug and Lug Hook (REL-3000H) prior to removal of load chain.

To remove chain place reversing lever in the down position, depress the thumb latch and pull on chain above bottom hook.

Clean and lubricate chain thoroughly.

See cleaning under **General Maintenance**

See lubrication under **Assembly** in this manual.

Inspect Load Chain for:

Bent or turned pins

Side plates that are spread or open.

Compare links in heavily used areas of chain to links at the free end to assess chain condition.

Locked or obstructed joints.

All joints should operate under light manipulation.

Corrosion, pitting or discoloration of chain

Wear or damage (i.e. gouges, nicks, weld splatter)

NOTE: Excessive wear, damage or deterioration described above should be addressed immediately. Manufacturer recommends replacement with chain and connecting links from RELIABLE EQUIPMENT.

PERIODIC INSPECTION

Inspect each part for wear, cracks, bending and distortion. Discard worn or damaged parts and replace with new factory authorized parts.

Clean and lubricate all parts and assemblies during inspection, and before disassembly.

If any Conditions requiring additional inspection or repair are found hoist shall be immediately tagged and repaired by a trained, designated technician before returning to operation.

Inspect all parts and operations as required by frequent and chain inspection criteria.

Lifting Lever should be removed to provide visual access prior to continuing the periodic inspection.

TO REMOVE LIFTING LEVER ASSEMBLY

Place reverse lever in the "UP" position.

Pull free end of chain assembly until bottom hook assembly contacts frame assembly.

Rotate lever cap screw counterclockwise to remove remaining slack, and continue turning. (Tension should increase slightly until screw begins to unthread from assembly) Continue until lever cap screw is free of lever assembly.

Remove Lever Washer.

Remove Lever Assembly from Hoist Body,

Check all nuts, bolts for damaged or stripped threads and rivets for looseness.

Check Lever for damage or distortion.

Check Trip Rod for damage or bending.

Inspect Lever Pawl Assembly and operation.

(Lever Pawl, Trip Pin, Release Spring, and Rivet)
Replace entire assembly if any component is bent, worn or damaged.

Check Lever Pawl for binding with Lever Pawl Pin.

Inspect Lever Pawl Spring and Release Spring.

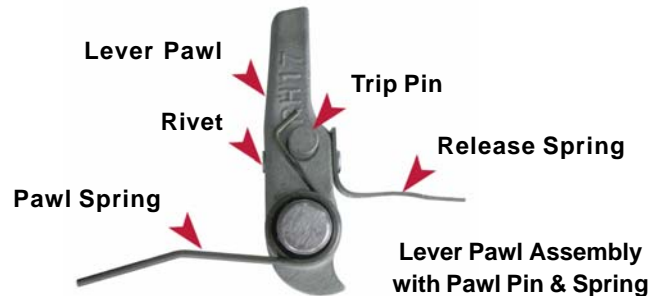

Confirm Thumb Latch activation of Lever Pawl.

Lever Pawl should move freely when latch is depressed, and return upon release.

(Minimum required clearance between Lever Pawl and Lever Bushing should be 5/16")



Inspect Safety Pin Assembly and Safety Spring.

Pull Safety Pin Knob and observe Lever Pawl action.

The pawl should move out toward the lever casting.

Check Safety Release Spring if the Lever Pawl does not move appropriately when Safety Pin Knob is pulled.



Inspect Lever Bushing for wear and scoring.

DO NOT disassemble Lever Assembly if no defects are disclosed by the inspections.

Inspect Sprocket shaft for excessive wear, scoring, damage to the teeth, or stripped threads.

Check lubrication port for obstruction.

Inspect Retaining Ring for wear or distortion.

Inspect Reverse Ring/Stationary Pin Assembly for damage, wear, loose or broken Pins, and worn or missing springs. Inspect Locking Pawl Release Pin for looseness.

Reverse Ring Assembly _____

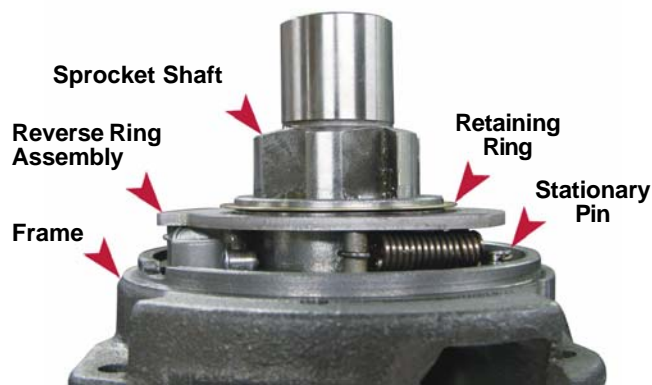

Reverse Ring / Stationary Pin Assembly _____

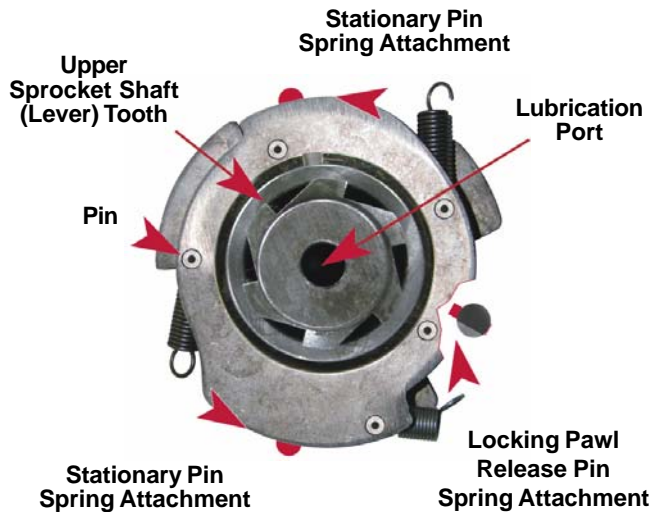

Check hoist body (Frame) for cracks, damage or distortion which may have been caused by misuse, overloading or dropping.

Disassembly is recommended to permit detailed internal inspection.

DISASSEMBLY OF HOIST BODY

Clamp hoist body assembly in a vise, and chisel the heads OFF of the six (6) Round Head Rivets.

Punch Rivets through Frame for removal.

Separate left frame from right frame.

Light force may be required to separate the Frame.

NOTE: Use CAUTION to avoid personal injury or damage to the Hoist Body/Frame Assembly.

Support Hook Assembly will be freed when frame halves are separated. (Secure or Support)

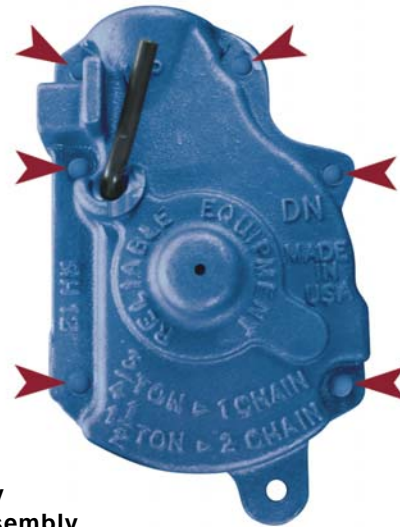

Hoist Body
Frame Assembly

Refer to Inner Frame Assembly illustration at the top of the following Page.

Inspect Reversing Lever and R.L. Spring for wear, damage or distortion.

Inspect (Chain) teeth on the lower Sprocket Shaft for wear, damage or distortion.

Inspect Locking Pawl and L.P. Spring for wear, damage or distortion.

Inspect Chain Shedder for wear or looseness.

Check all Frame surfaces which mate with (Seat) Sprocket Shaft, Locking Pawl and Support Hook for wear and scoring.

Inspect Support Hook using dye penetrant, magnetic particle inspection (Magnaflux) or other acceptable detection method.

DO NOT remove Safety Latch Assembly from Hooks If no defects are disclosed by the inspections.

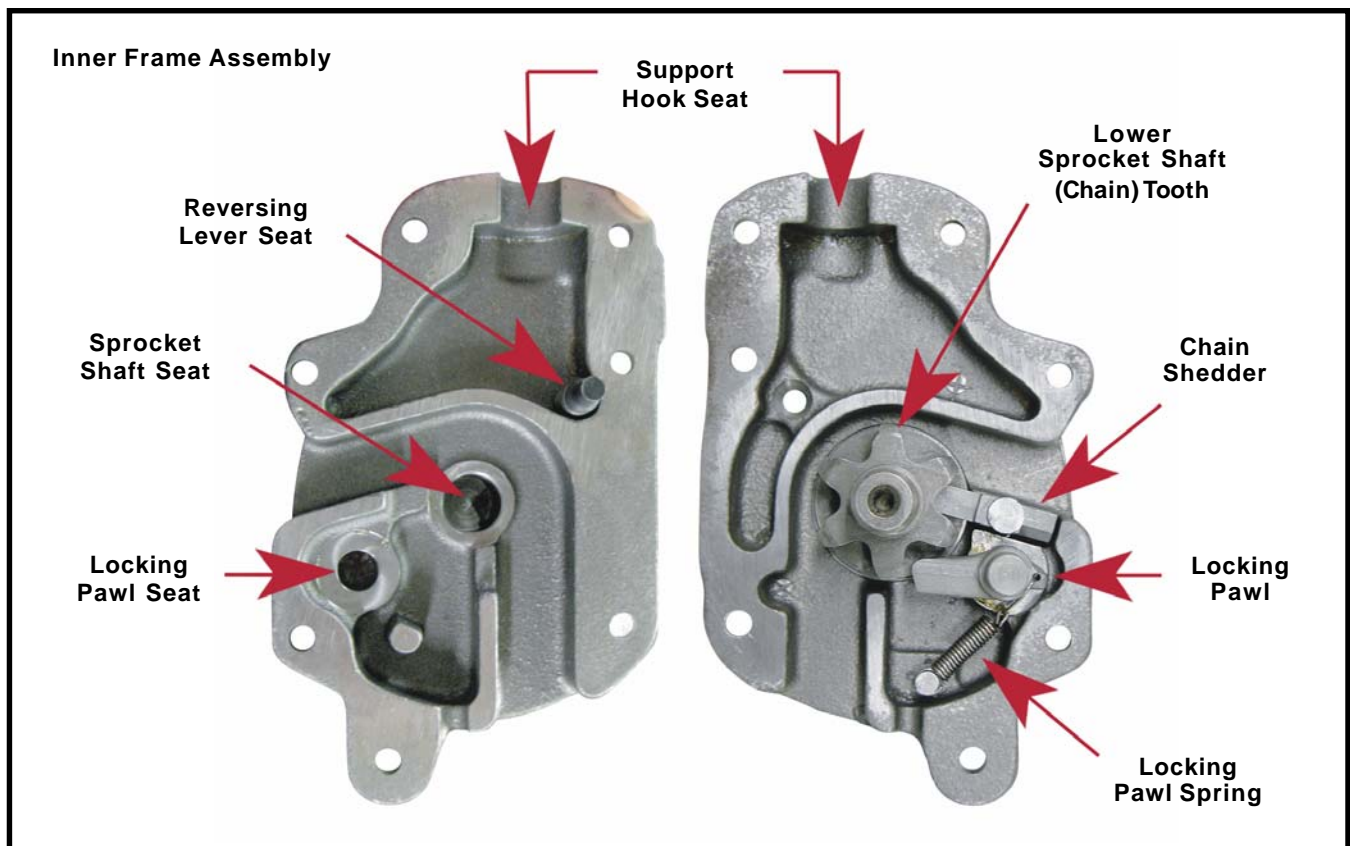

Complete Disassembly is not recommended.

In the event that an inspection reveals the need for repair or replacement of a part or assembly: Repair and testing should be performed by a trained, designated technician before returning hoist to operation.

DISASSEMBLY AND PARTS REPLACEMENT LEVER ASSEMBLY

Clamp Lever Assembly in a vise, and chisel the heads OFF of the two (2) Round Head Rivets. Punch Rivets through Lever and Lever Pawl Cover. Free Lever Pawl Pin from Lever Pawl Cover. Remove Lever Pawl Cover from Lever Assembly. Punch Roll Pin through Lever to free Thumb Latch.

Remove Trip Rod from Thumb Latch and remove Thumb Latch from Lever Handle.

Remove Trip Rod from Lever Pawl Assembly.

Remove Lever Pawl Spring.

Remove Lever Pawl Assembly from Lever Pawl Pin and Trip Rod.

Replace entire Lever Pawl Assembly if any component is bent, worn or damaged.

Punch Safety Pin Assembly through Safety Pin Knob & Lever (Handle).

Note: Safety Spring will be free for removal.

Replace entire Safety Pin Assembly if any component is bent, worn or damaged.

Press Lever Bushing from Lever.

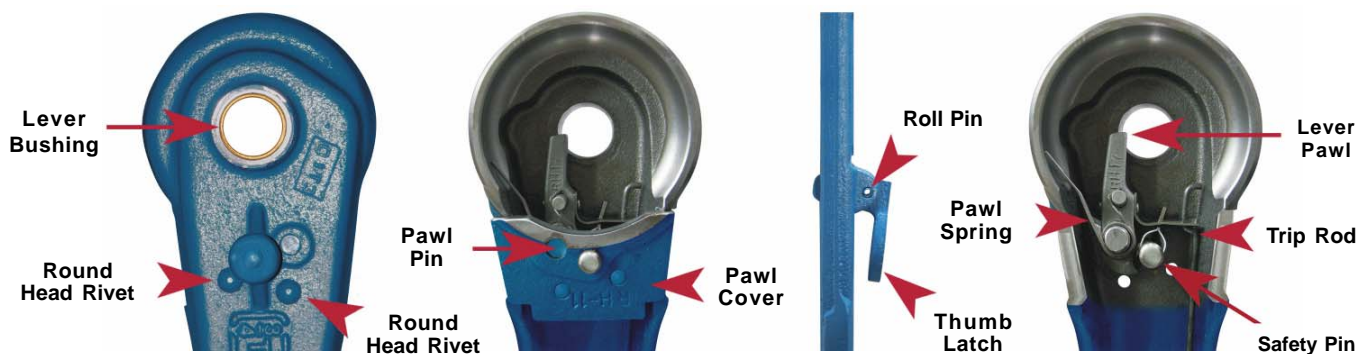

CHAIN, LOAD BLOCK (FRAME) & SAFETY HOOK

Bottom Hook Assemblies

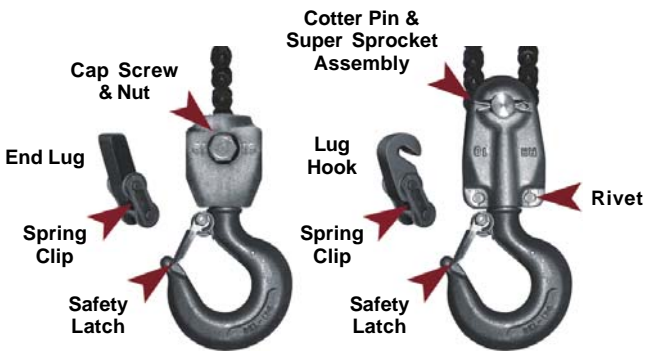

REL-1500 Swivel Frame REL-3000 Super Frame

Remove chain attachments: **REL-1500H.**

To remove the End Lug, remove the spring clip from the connecting link and punch link pins through side plates.

To remove the Swivel Frame, remove the Hex Nut and Cap Screw from the Frame & Chain Assembly.

Note: The chain will be released upon removal of the Cap Screw, and the Hook Assembly will be released upon separation of Swivel Frame halves.

Remove chain attachments: **REL-3000H.**

To remove the Lug Hook, remove the spring clip from the connecting link and punch link pins through side plates.

To remove the End Lug, remove the spring clip from the connecting link and punch link pins through side plates.

To Disassemble the Super Frame, remove the Cotter Pins from the Super Sprocket Pin and remove the Super Sprocket Pin & Super Sprocket Bushing Assembly from the Super Frame Assembly. Press Bushing from Super Sprocket.

Place the Super Frame in a vise and chisel off the heads of the pulling hook rivets to separate halves.

Note: The Hook Assembly will be FREE (released) upon separation of Swivel Frame halves.

Remove Safety Latch Assembly by unthreading the nut and bolt found at the throat of the Hook.

DO NOT remove Safety Latch Assembly from Hooks If no defects are disclosed by the inspections.

Reverse Ring Assembly

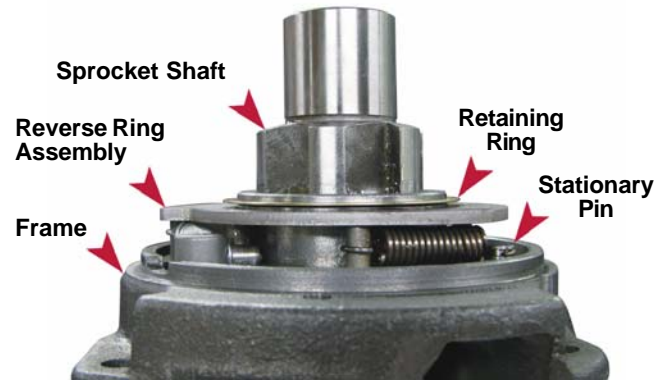

Remove Reverse Ring Retaining Ring.

Remove two (2) Reverse Ring Springs from the Stationary Pins, and the Locking Pawl Spring from the Locking Pawl Release Pin.

Reverse Ring / Stationary Pin Assembly

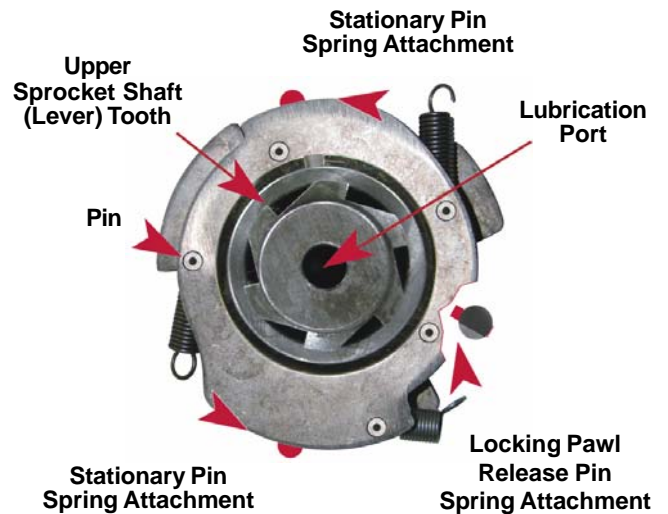

Turn Locking Pawl to a position which allows the Locking Pawl Release Pin to be punched through the Pawl from the inside.

Slide the Reverse Ring Assembly OFF of the Right Frame and Sprocket Shaft.

Locking Pawl Release Pin Assembly

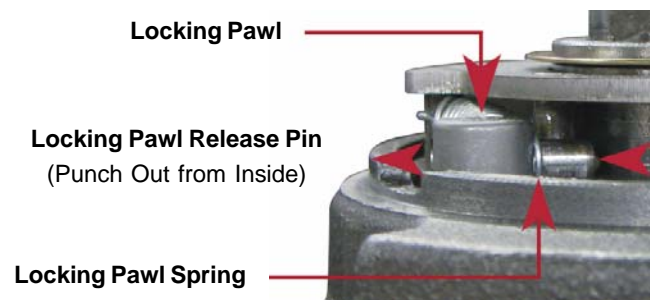

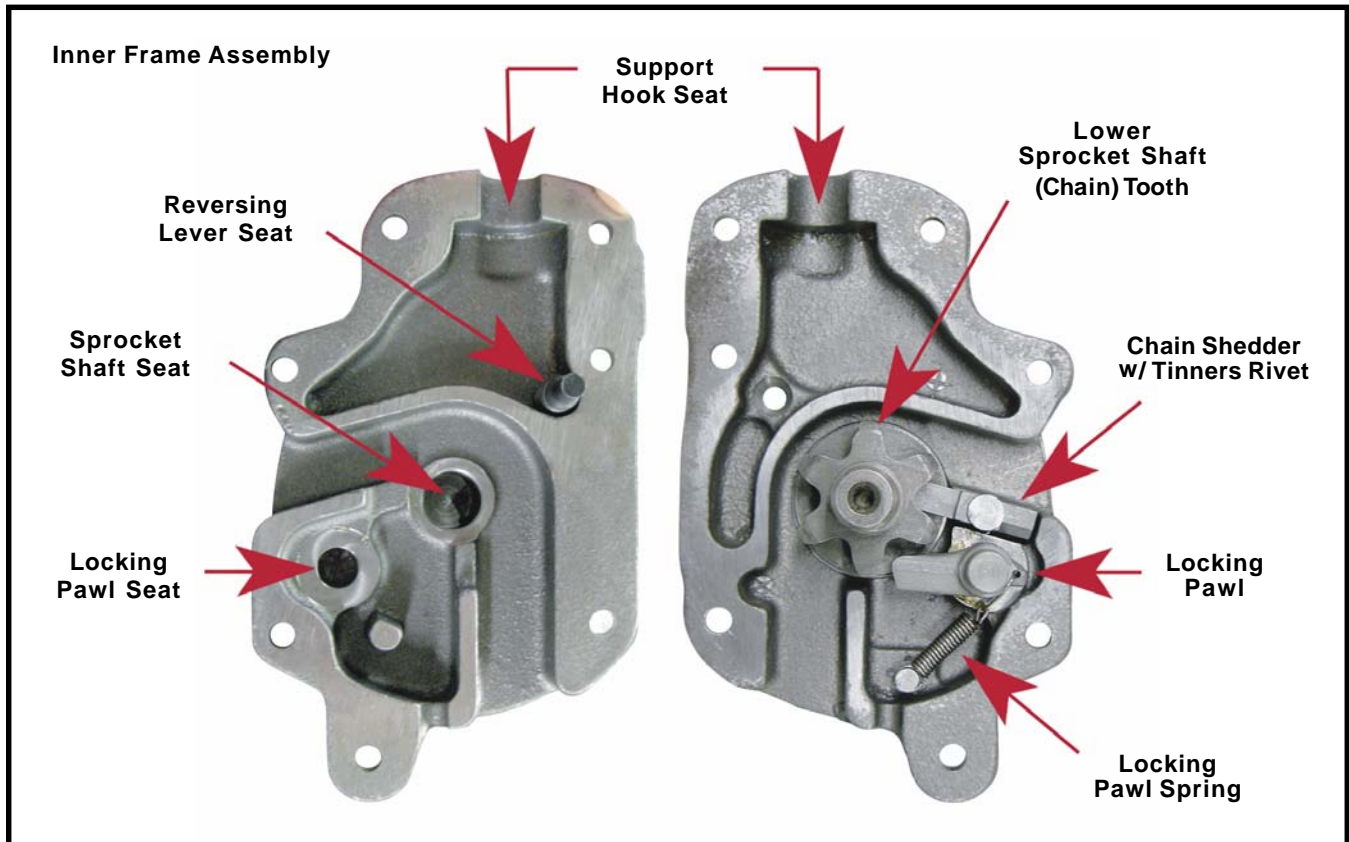

Remove Reversing Lever & Lever Spring by guiding Reversing Lever through the inside of the Left Frame. Secure Right Frame Assembly in vise.

Remove Locking Pawl Spring from Stationary Pin. The Locking Pawl and Pawl Spring will be FREE for removal from Right Frame.

Remove Tinners Rivet to release Chain Shedder. Sprocket Shaft is FREE for removal from Frame. Press Stationary Pins from Right Frame ONLY if replacement is required.

In cases where damage to the hoist or internal assemblies has occurred, and the chain is lodged within the assembly, it is recommended that the manufacturer be contacted at 800-966-3530 for instruction specific to the individual case at hand.

Inspect each part for wear, cracks, bending and distortion. Discard worn or damaged parts and replace with new factory authorized parts.

HOIST BODY ASSEMBLY

Install Reversing Lever Spring over Reversing Lever and seat on shoulder of Lever.

Work Reversing Lever through Left Frame.

Press three (3) Stationary Pins into Right Frame ONLY if replacement is required.

LUBRICATE Sprocket Shaft with a multipurpose lithium base bearing grease.

Insert Sprocket shaft through Right Frame.

Install Chain Shedder between Lower Sprocket teeth and Shaft Body, secure using Tinners Rivet.

Connect Locking Pawl Spring to Locking Pawl.

LUBRICATE Locking Pawl with SAE 20-30 gear oil.

Insert Locking Pawl through the Right Frame and attach Spring to Stationary Pin.

LUBRICATE Support Hook with SAE 20-30 gear oil.

Place Support Hook Assembly into Hook Seat. Mate Left & Right Frame halves, and secure with Six (6) Round Head Rivets.

IF YOU HAVE ANY QUESTIONS REGARDING THE PROPER USE OPERATION OR MAINTENANCE OF THIS TOOL, CONSULT YOUR AREA SUPERVISOR, OR CONTACT RELIABLE EQUIPMENT & SERVICE CO., INC. AT 800-966-3530

BOTTOM HOOK ASSEMBLIES

If Safety Latch Assembly has been removed attach NEW Latch Assembly to Bottom Hook.

SWIVEL FRAME (REL-1500H)

LUBRICATE Hook Shank with SAE 20-30 gear oil.
 Insert Hook Assembly between Frame Halves
 Insert Chain between Swivel Frame halves.
 Swivel Half Lug must fit into second link of Chain.
 Insert Cap Screw through first link of Load Chain.
 Install Nut to complete Hook assembly.

Bottom Hook Assemblies

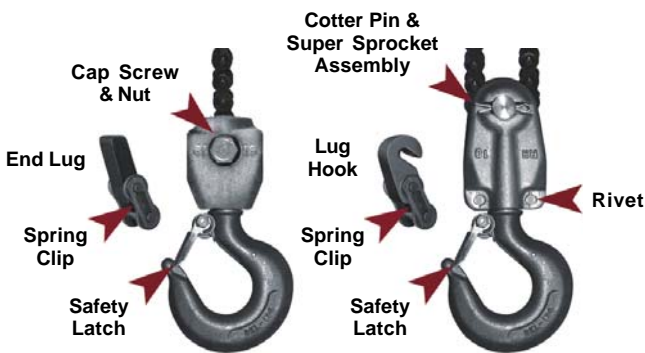

REL-1500 Swivel Frame

REL-3000 Super Frame

SUPER FRAME (REL-3000H)

LUBRICATE Hook Shank with SAE 20-30 gear oil.
 Insert Hook Assembly between Frame Halves.
 Assemble Frame with two (2) Pulling Hook Rivets.
 LUBRICATE inner Super Sprocket Bushing and Outer Super Sprocket Pin with SAE 20-30 gear oil.
 Place Super Sprocket Assembly into Super Frame.
 Insert Super Sprocket Pin and secure with two (2) Cotter Pins.

Feed Load Chain Through Super Frame Assembly.

REVERSING RING & STOP PIN ASSEMBLY

Install two (2) Reverse Ring Springs and Release Pin Spring onto Reversing Ring Assembly.

LUBRICATE mating surfaces of Right Frame and Reversing Ring-Stationary Pin Assembly with a calcium base bearing grease

Turn Reverse Lever to DOWN, retracting Stop Pin.
 Align Reversing Ring Assembly with Stop Pin.
 Slide the Reverse Ring Assembly onto the Right Frame and Sprocket Shaft.

Reverse Ring / Stationary Pin Assembly

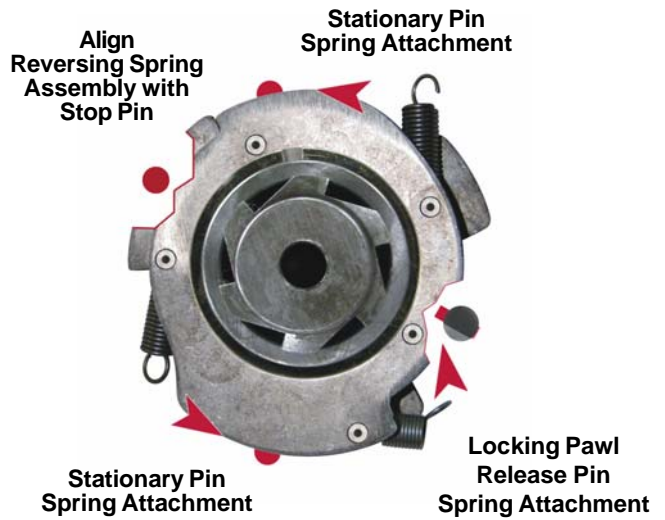

Install Reverse Ring Springs on Stationary Pins.
 Align flats of Locking Pawl and Release Pin, and drive Pin into Pawl until Pin extends slightly beyond inner Pawl.

Place Locking Pawl Spring over Release Pin, and drive Pin until Pin is flush with outer Pawl.

Locking Pawl Release Pin Assembly



Install Ring Retaining Ring.
 Turn Reversing

Reverse Ring Assembly

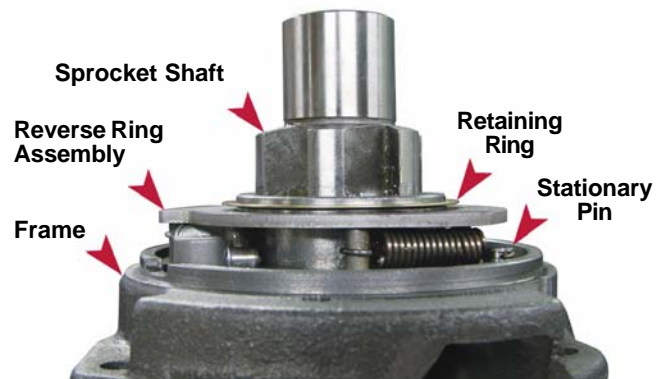

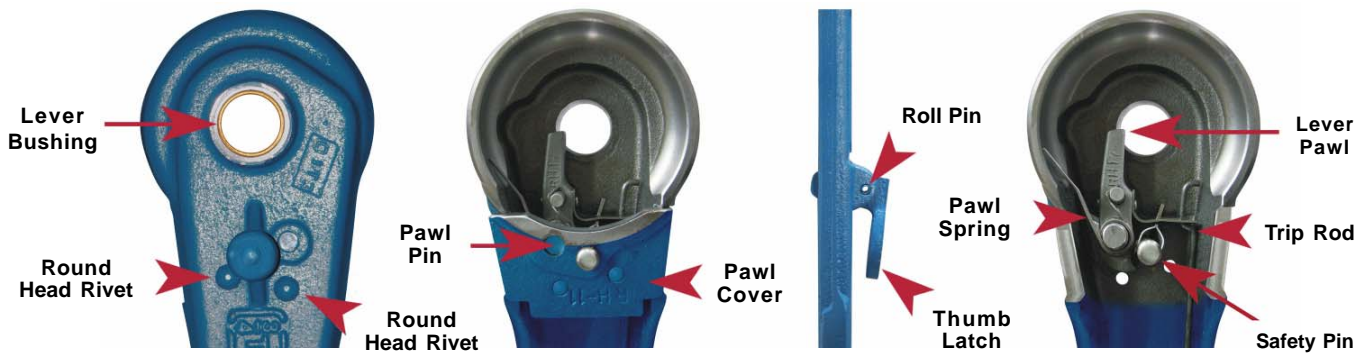

LEVER ASSEMBLY

Press Lever Bushing into Lever.

LUBRICATE Safety Pin Assembly & Spring with a light coating of bearing grease with graphite.

Install Safety Pin Spring onto Assembly.

Insert Safety Pin Assembly through Lever, compressing Safety Pin Spring to allow Installation of Safety Pin Knob. Rivet over the end of the Safety Pin Assembly.



Inner Lever Assembly

Insert Thumb Latch through Lever, and install lower Trip Rod through outer hole in Thumb Latch.

Secure Thumb Latch to Lever with a Roll Pin. LUBRICATE Lever Pawl Pin & holes in Lever Pawl Assembly with a light coating of bearing grease with graphite.

Insert upper end of Trip Rod through outer hole in Lever Pawl Assembly (Release Spring).

Insert the End Spring of Safety Pin Assembly into inner hole in the Lever Pawl Assembly (Release Spring).

Move Lever Pawl Assembly into position and insert Lever Pawl Pin through Lever Pawl Assembly and Lever.

Compress Lever Pawl Spring and install Lever Pawl Spring over Lever Pawl Pin, with Long side of Spring pressing against inside of Lever housing and short end of Spring nested against Lever Pawl Trip Pin.

Install two Round Head Rivets through Lever and Lever Pawl Cover.

Pressing Thumb Latch, mate Lever Assembly with Hoist Body Assembly, over Sprocket Shaft, and install Lever Washer and Cap Screw,

INSTALLATION OF LOAD CHAIN

LUBRICATE entire Load Chain thoroughly with a penetrating oil containing graphite.

Turn Reverse lever to the UP position and insert Load chain into Lower Hoist Body (Frame) as far as possible.

Operate Lever until a manageable length of chain extends from the side of the Hoist Body (Frame).

Install the Chain End Lug with a Connecting Link and Spring Clip.

Assembly is complete for the **REL-1500H** hoist.

**REL-3000
Load Chain and
Lug Hook Connection**



Install the Lug Hook onto the other end of the Load Chain with a Connecting Link and Spring Clip.

Install Connecting Link to Bottom of Hoist Body and connect Lug Hook to Connecting Link.

Assembly is complete for the **REL-3000H** hoist.

