

OPERATORS' GUIDE

REL-1915

ELECTRIC HIGH PRESSURE SINGLE/DOUBLE ACTING HYDRAULIC PUMP

The REL-1915 Portable Electric High Pressure Hydraulic Power Pump. This intermittent duty two stage pumping system features a high pressure piston style pump, complimented by a low pressure pump for rapid tool advance. The 5/8 HP universal electric motor will operate from any 115V AC power supply.

WARNING



All information found in this guide must be read and understood before use or testing of this tool.

Failure to read and understand these warnings and safe handling instructions could result in severe personal injury and or death.

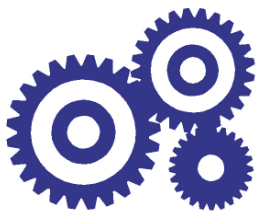

RELIABLE EQUIPMENT & SERVICE CO., INC.

TABLE OF CONTENTS

Registration	2	Reservoir Clean & Fill.....	13
Tool Quick Reference	3	Major Components (Fig. 1 & 2) ..	14-15
General Safety Issues	4-6	External Assembly (Fig. 3).....	16
SPECIFICATIONS			
General	7	Motor Assembly (Figure 4)	17
Pre-Operation.....	7	Pump Block Assy (Figure 5)	18-19
Hydraulic Fluids	7	Drive Gear Assy (Figure 6)	20
Connections and Hoses	8	REL-DIR-VALVE	21
Operation (Single Acting)	9	Valve Assembly (Figure 7)	22-23
Operation (Double Acting)	10	Maintenance Record	23
MAINTENANCE			
General	11	Phone, Fax & Address	24
Troubleshooting	12		
Before Disassembly	13		

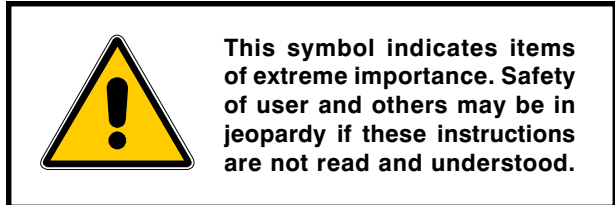

REGISTRATION

UPON RECEIPT OF THIS TOOL, COMPLETE THE REGISTRATION BELOW.

COMPANY _____

ADDRESS _____

PHONE _____ FAX _____

SERIAL NUMBER _____

DATE OF PURCHASE _____

DEALER NAME _____

REL-1915

ELECTRIC HIGH PRESSURE SINGLE/DOUBLE ACTING HYDRAULIC PUMP

The REL-1915 portable Electric High Pressure Hydraulic Power Pump. This intermittent duty two stage pumping system features a high pressure piston style pump, complimented by a low pressure pump for rapid tool advance. The 5/8 HP universal electric motor will operate from any 115V AC power supply.

FEATURES:

- 5/8 HP electric motor
- Two stage pumping system
- 10,000 PSI high pressure pump
- Designed for use with single or double-acting remote tools
- High-pressure relief valve
- Factory filled oil reservoir
- Hand control with 8' cord
- Carrying handle
- Optional carrying case

Electric Motor

5/8 HP, 0.47kw, 3,000 RPM
115V AC 11 Full Load AMPS

Electrical Control

Body mount toggle switch and removable remote hand control with 8 foot twist lock cord.

Oil Delivery Per Minute

160 cubic inches at 100 PSI
30 cubic inches at 10,000 PSI

Oil Reservoir

3 quarts (.75 gallon)



Dimensions

8"W x 8"D x 15"H

Pump Weight W/ Oil

35.72 pounds



Consult your **RELIABLE** representative for more information about our complete line of hydraulic tools.



WARNING

BEFORE USING THIS TOOL, READ THE WARNINGS and the recommended practices described in this manual. Failure by the operator to read and fully understand these warnings will leave this person unqualified to use and operate this tool. Property damage, severe personal injury, and/or death could result by not following these warnings.

These warnings will appear in appropriate locations when they are pertinent to the particular subject being shown. Read each one carefully and follow them strictly.



Eye Protection

WARNING

Always wear eye protection to avoid injury from flying debris or hydraulic oil leaks. Failure to do so can result in serious personal injury.



Dust Mask

WARNING

Always wear a Mask. Failure to observe this warning may result in serious health issues and/or breathing difficulty.



Hard Hat

WARNING

Always wear a hard hat to avoid injury from falling debris. Failure to do so can result in serious personal injury.



Foot Protection

WARNING

Always wear foot protection. Failure to do so can result in serious personal injury.



Hearing Protection

WARNING

Always wear hearing protection, to avoid hearing loss due to long term exposure to high noise levels.



Operation/Safety methods may vary in accordance with the working guidelines established by each utility or contractor.

WARNING

For your own safety, ensure that you fully comply with all safe operation guidelines required by your employer.



WARNING

Safe Operation & Care

USE THIS TOOL FOR ITS INTENDED PURPOSE ONLY
Any other use can result in injury or property damage.

INSPECT TOOL BEFORE USE. Replace any worn, damaged or missing parts. A damaged or improperly assembled tool may malfunction, injuring operator and/or nearby personnel.

INSPECT HYDRAULIC HOSES AND COUPLINGS before each use. Repair or replace if any cracking, leakage, wear or damage is found. Worn or damaged hoses may fail resulting in personal injury or property damage.

CLEAR WORK AREA of all bystanders and unnecessary personnel before operating this tool.

KEEP ALL PARTS OF THE BODY AWAY FROM MOVING PARTS.

Failure to observe this warning could result in serious injury.



WARNING

Safety

DO NOT attempt to make any changes to any of the component parts or accessories when connected to the power source.

DO NOT adjust, inspect, or clean tool while the tool is connected to the power source. The tool could accidentally start up and cause serious injury.

DO NOT lock the tool in the On Position. In an emergency, serious damage or injury could occur during the time required to stop the tool.



WARNING

Oil Injection Injury

Hydraulic oil or fluid under the skin is a serious injury. Oil under pressure can penetrate the skin and may cause dismemberment or loss of life. Seek medical assistance immediately if such an injury should occur.

Always wear safety gloves, eye protection and all required safety equipment when operating or handling this tool.

DO NOT use fingers or hands to attempt to locate a leak.

DO NOT handle hoses or couplers while system is pressurized.

NEVER open or service the system before depressurizing.



WARNING

Burn Hazard

Do Not connect or disconnect tool, hoses or fittings while power source is running or while hydraulic fluid is hot. Hot hydraulic fluid may cause serious burns.

Failure to observe this warning could result in serious injury.



WARNING

Electrical Shock Hazard

Use only certified nonconductive hoses and fittings. Always wear and use the necessary clothing, equipment and safety practices to protect against electrical shock. Failure to follow these rules can result in serious personal injury or death.



CAUTION

Safe Handling

HYDRAULIC FLUID MAY CAUSE SKIN IRRITATION.

Prevent hydraulic fluid from making contact with skin.

IN THE EVENT OF SKIN CONTACT immediately wash thoroughly.

Failure to observe this warning could result in injury.



CAUTION

General Safety

Ensure that all fellow employees and bystanders are clear and protected from possible injury caused by this tool or the operations being performed. Persons in close proximity could be injured and property damaged if the tool were to malfunction.

This tool should always be used within the limits and purposes stated by the product manufacturer. Abuse or usage beyond the manufacturers' intended purposes could cause damage to the tool and severe injury to the operator.

NOTICE

If you have any questions regarding the information found in this manual please contact RELIABLE EQUIPMENT before continuing.
Phone: 215-357-3500 Toll Free: 800-966-3530 Fax: 215-357-9193

TOOL SPECIFICATIONS

Height	15 in.
Depth	8 in.
Width	8 in.
Weight	35.72 lbs.
Electric Motor	115V AC
.....	5/8 hp
Pump System	Two Stage Piston Style
Tool Operation	Single or Double Acting
Operating Pressure	10,000 psi
Relief Setting (factory pre-set)	10,000 psi
Oil Reservoir	3 quarts
Oil Delivery Per Minute	160 cubic inches at 100 psi
.....	30 cubic inches at 10,000 psi

PRE-OPERATION OF TOOL



WARNING

DO NOT connect hoses or fittings to pump before completing all of the instructions in this section.

Ensure power source is **OFF**, and hydraulic flow is turned **OFF**.

Failure to comply with this warning can result in severe injury or death.

Before attempting to run or use the REL-1915 pump, check all connections, including hoses, and couplings. (See WARNINGS on page 8)

Wear all safety items required and make sure that the working area is clear of obstructions and non-essential personnel.

HYDRAULIC FLUIDS

All hydraulic fluids that meet these listed specifications or the listed HTMA specifications may be used for this tool.

S. U. S.

@ 100° F (38° C) 140 TO 225

@ 210° F (99° C) 40 minimum

FLASH POINT 340° F min. (170° C min.)

POUR POINT -30° F min. (-34° C min.)



WARNING

HOSES AND FITTINGS

There exists the potential for shock in using anything other than certified nonconductive hoses and hydraulic oil with dielectric properties, when using system components near energized electrical lines. Failure to recognize these conditions could cause electrocution.

Hoses and fittings used with this tool must comply with S.A.E. J1273 which covers recommended practice for selection, installation, and maintenance of hose and hose assemblies. The **correct hoses and fittings are available from your supplier.**

WARNING: Failure to comply with these warnings could result in severe bodily injury.



WARNING

UNIT/HOSE CONNECTIONS

ALWAYS DISCONNECT pump/power source and move toggle switch to **OFF** before connecting or disconnecting any components.

ALWAYS DEPRESSURIZE hydraulic system, before slowly disconnecting this unit or any of the systems components.

ALWAYS TIGHTEN couplings completely. Loose or improperly tightened couplings will not allow fluid to pass through the hose creating a blockage in the supply or return line.

ALWAYS INSPECT HOSES AND CONNECTORS before connection to tool. Replace or repair if any leakage is evident. Leakage is a sign of deterioration in component parts. Worn or leaking parts must be repaired or replaced, or tool damage or severe injury could result.



CAUTION

HOSE INSTALLATION

ALWAYS ENSURE CONNECTORS ARE CLEAN

SINGLE ACTING - Connect the hose to the pressure port on the power source, then connect to the port on the tool.

DOUBLE ACTING - Care must be taken to assure the correct connection of the hoses to the pressure and return (tank) ports.

Connect the return hose to the return (tank) port on the power source, then to the return port on the tool.

Connect the pressure hose to the pressure port on the tool, then to the "P" pressure port on the power source.

Operation with hydraulic flow reversed can cause malfunction. Failure to fully comply can result in severe injury or death.

SINGLE ACTING PUMP OPERATION

There are a number of safety items that need to be addressed when using the tool. Seek out the supervisor for basic instruction in handling the tool. Some basic problems are easily overcome by knowing the rules of operation.

Inspect, set-up and connect the tool as described on the previous pages.

Refer to photos and diagrams on the following pages as needed.

Connect to 115V electric power source.

Plug remote hand control switch (included) into pump.

NOTE: REMOTE HAND CONTROL IS AVAILABLE FOR SINGLE ACTING OPERATION ONLY.



WARNING

Turning on toggle switch may prematurely begin tool operation.

Remote hand control switch will operate pump without turning on manual toggle switch located on motor housing.

Toggle switch may be used in place of pendant switch for single acting operation. Note: A 4-way valve may also be used for added control.

Open vent.

Set up desired operation (ie. crimp, cut, or spearing).

Activate pump using remote hand control by depressing intermittent switch.

NOTE: For operator safety, control remains active only while switch is depressed.

When relief valve popping occurs desired pressure has been achieved.

Release button and allow tool to retract.

NOTE: Holding switch ON after relief valve has popped will cause unnecessary wear on relief valve and pump assembly.



WARNING: DO NOT disconnect the tool, hoses, or fittings while the tool is running, hot, or under pressure. Serious injury or burns could result.

DISCONNECTING HOSES

Turn pump OFF and disconnect from power source.

Disconnect the pressure hose from the pressure “P” port on the pump, then disconnect the hose from the pressure port on the tool.

Disconnect the return hose from the return “T” port on the tool, then disconnect the hose from the return (tank) port on the pump.

Install dust caps on all connectors to prevent dirt and contaminants from entering the hydraulic system.

Refer to photos and diagrams on the following pages as needed

DOUBLE ACTING PUMP OPERATION

There are a number of safety items that need to be addressed when using the tool. Seek out the supervisor for basic instruction in handling the tool. Some basic problems are easily overcome by knowing the rules of operation.

Inspect, set-up and connect the tool as described on the previous pages.

Refer to photos and diagrams on the following pages as needed.

Connect to 115V electric power source.

NOTE: REMOTE HAND CONTROL IS AVAILABLE FOR SINGLE ACTING OPERATION ONLY.

Remote switch is not necessary for double acting operation. Tool is controlled by an in-line control valve.

Open vent

Set up desired operation (ie. crimp, cut, or spearing).

Turn pump on at toggle switch.

For tool operation, use an in-line 4-way control valve (ie. PVA-0022 or PVA-1122) to advance and retract tool ram.

When relief valve popping (audible) occurs desired pressure has been achieved.

Retract tool using 4-way valve.

NOTE: Holding valve ON after relief valve has popped will cause unnecessary wear on relief, valve and pump assembly.



WARNING: DO NOT disconnect the tool, hoses, or fittings while the tool is running, hot, or under pressure. Serious injury or burns could result.

DISCONNECTING HOSES

Turn pump OFF and disconnect from power source.

Disconnect the pressure hose from the pressure “P” port on the pump, then disconnect the hose from the pressure port on the tool.

Disconnect the return hose from the return “T” port on the tool, then disconnect the hose from the return (tank) port on the pump.

Install dust caps on all connectors to prevent dirt and contaminants from entering the hydraulic system.

Refer to photos and diagrams on the following pages as needed

SCHEDULED MAINTENANCE

The life, reliability, and safety of the tool is dependent on proper maintenance.

DAILY MAINTENANCE

Clean all surfaces including, hand control, fittings, hoses and housing.

Inspect tool for wear and damage. Worn or damaged parts can cause malfunction.

Inspect for cracked hoses and leaking fittings.

Check fluid level of the power source reservoir frequently.

Remove Vent to add hydraulic fluid as needed. *Replace vent immediately. (see page 12)*

All the above items must be replaced with new parts if signs of wear are evident.

FLUID CONTAMINATION: Cover the ends of fittings with a dust cap when disconnected. This will help keep the fluid from contamination. **(See Reservoir Clean & Fill on pg 15)**

MONTHLY MAINTENANCE: Inspect per Appendix A, SAE Standard J1273, 5/86 for hose or fitting damage such as wear, cracks or leakage; replace the necessary parts.



IMPORTANT: The greatest cause of hydraulic pump failure is dirt. Prevent the introduction of foreign matter into the unit via hydraulic fluid, dirty connections or accumulation of sediment.

NOTE: Keep Label Set clean and legible. Replace decals when necessary. Part #RL22400



WARNING

BEFORE USING THIS PRODUCT READ THE SAFETY WARNINGS and recommended practices described in the manual. Failure by the operator to read and fully understand the warnings will leave this person unqualified to use and operate the tool.

Failure to observe all warnings and instructions could result in property damage, severe personal injury, and/or death.

MOTOR SPEC. PLATE (METAL)
(see pg 12) Order part #1915-DP

HP	5/8	VOLTS	115
FL AMPS	11	PH	1
CYCLES	60	3000 RPM FL	
INSULATION CLASS B			
ROTATION CCW FACING			
COMMUTATOR END			

1915-DP

CAUTION

Operation and safety methods may vary in accordance with the guidelines established by each utility. For your safety, ensure that you fully comply with all safe operation guidelines established by your respective power utility.

REL-SM

DANGER

The user should be properly trained in the correct procedures required for work on or around electrical lines.

DANGER

EXPLOSION HAZARD
DO NOT operate motor where explosive vapors or flammable materials exist. Death or serious injury will result. Check NEC and local codes before installing.

CH-1800-EH

**OPEN VENT VALVE
BEFORE OPERATING.**

CLOSE AFTER

← **USE.**

1915-V

TROUBLESHOOTING

Determine the source (i.e. tool or hydraulic system) **of the problem before trouble shooting.**

Will not run

Improper power source Verify power source meets specifications 115V AC

Motor runs but pump will not operate

Low hydraulic fluid Check fluid level
Incorrect viscosity Use recommended fluid
Pump damaged Repair by authorized technician
Hoses incorrectly connected Switch hoses (*see hose connection in this manual*)
Dirt in pump Disassemble, clean and repair

Pump runs slow

Power supply not functioning correctly Reset to operator manual specs.
Fluid not warmed to correct temp Allow a warm-up period
Fluid viscosity too high See recommended viscosity
Air in hydraulic system Check hoses for breaks, leaks, or loose connections
Hydraulic fluid level low Fill to level. Check for leaks
Worn or damaged components Replace worn or damaged components

Pump operation is erratic

Hydraulic fluid not warm Allow oil to warm up
Dirt or contaminants in tool Clean and reassemble
Air in system Check hoses for breaks, leaks, or loose connections

Pump runs continuously

Tool locked in "ON" position Release toggle switch

Pump runs hot

Low fluid level Fill pump reservoir to correct level
Fluid viscosity incorrect Use recommended fluid
Fluid dirty Drain tank, flush, and replace fluid
Worn or damaged O-rings or gaskets Replace worn or damaged components

Pump leaks hydraulic fluid

Worn or damaged seals Disassemble and replace worn or damaged seals
Components loose Tighten component hardware

Pump lacks power

Control valve leaking Worn part or seal rings

NOTICE

If you have any questions regarding the information found in this manual please contact RELIABLE EQUIPMENT before continuing.
Phone: 215-357-3500 Toll Free: 800-966-3530 Fax: 215-357-9193

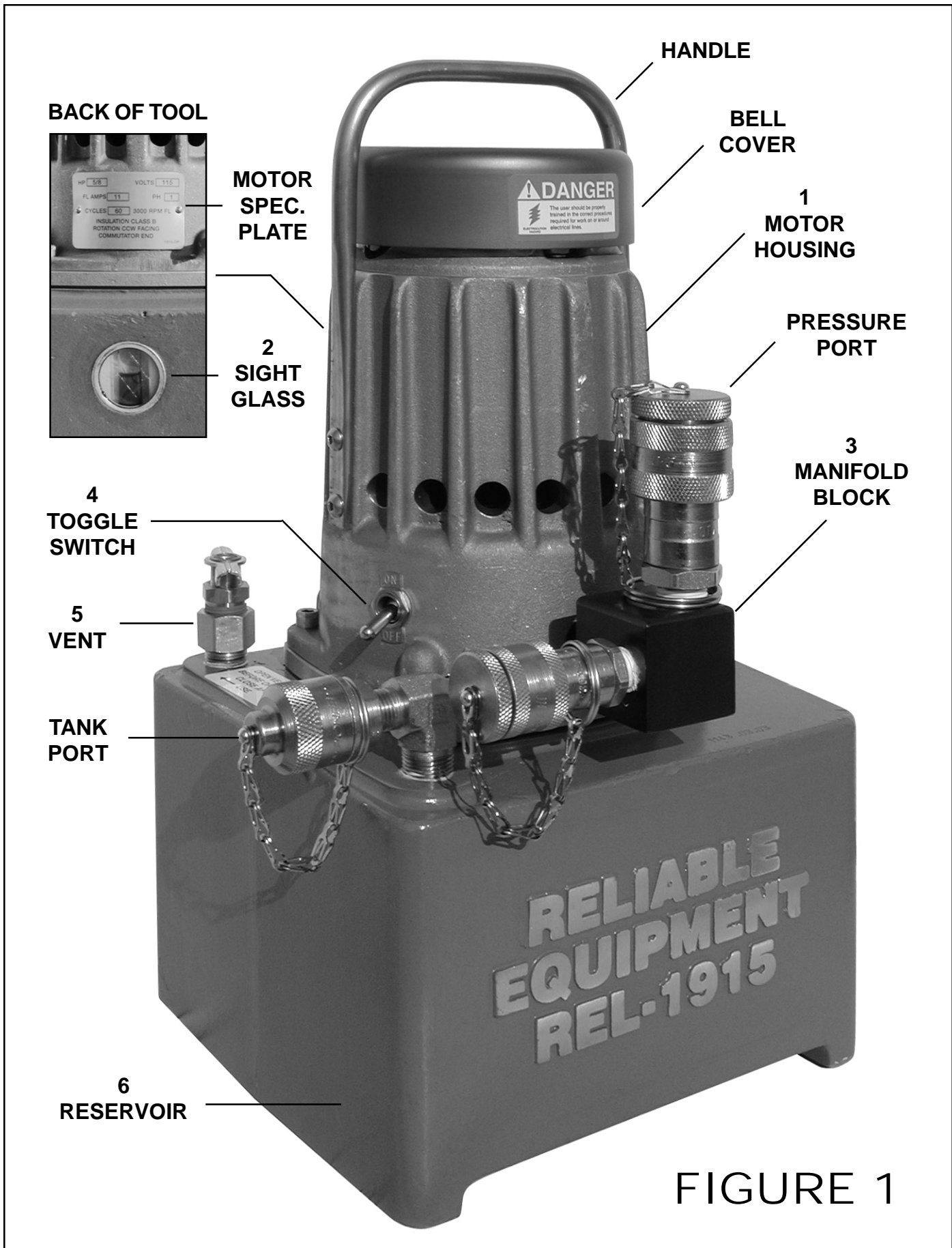
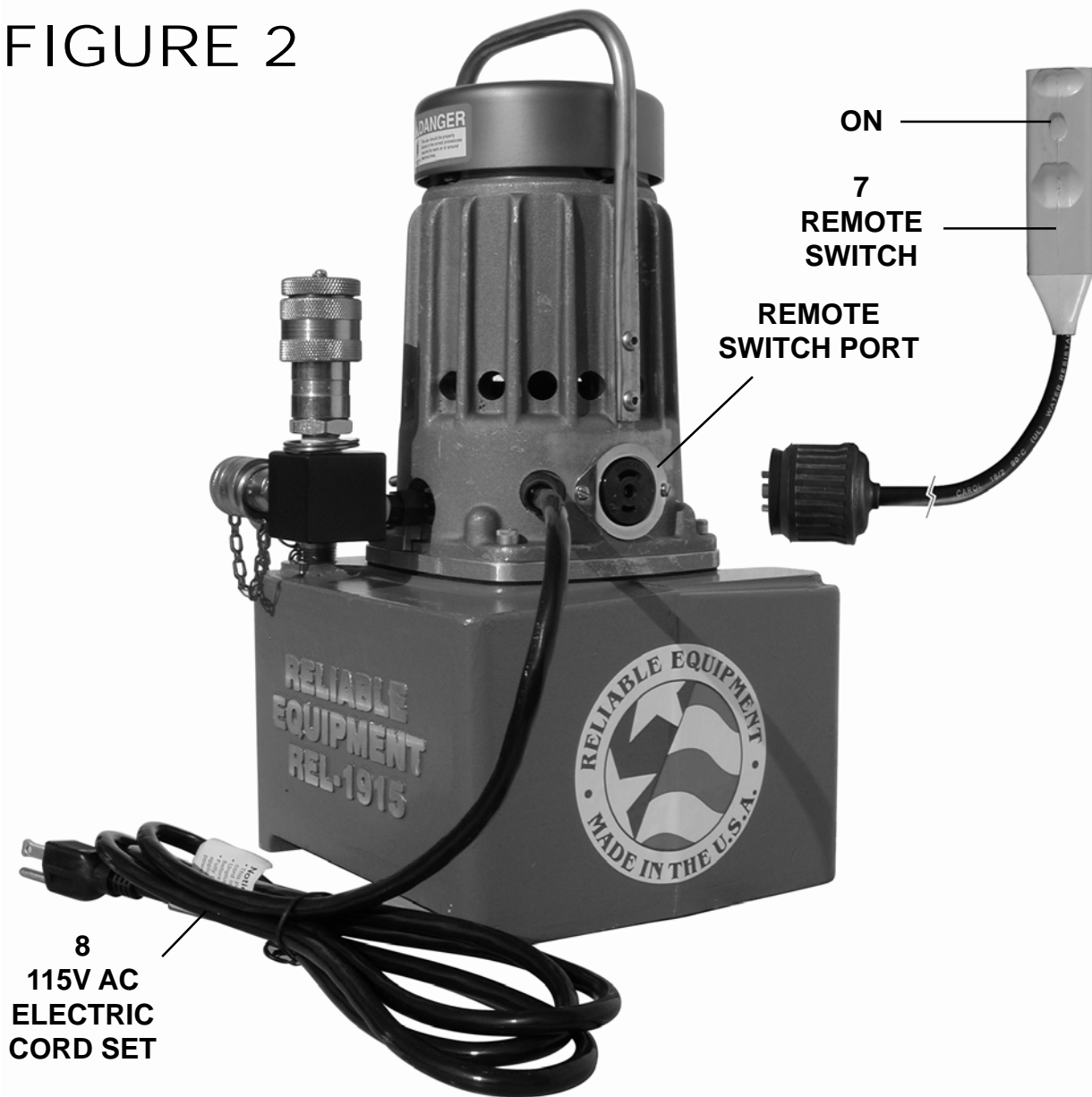
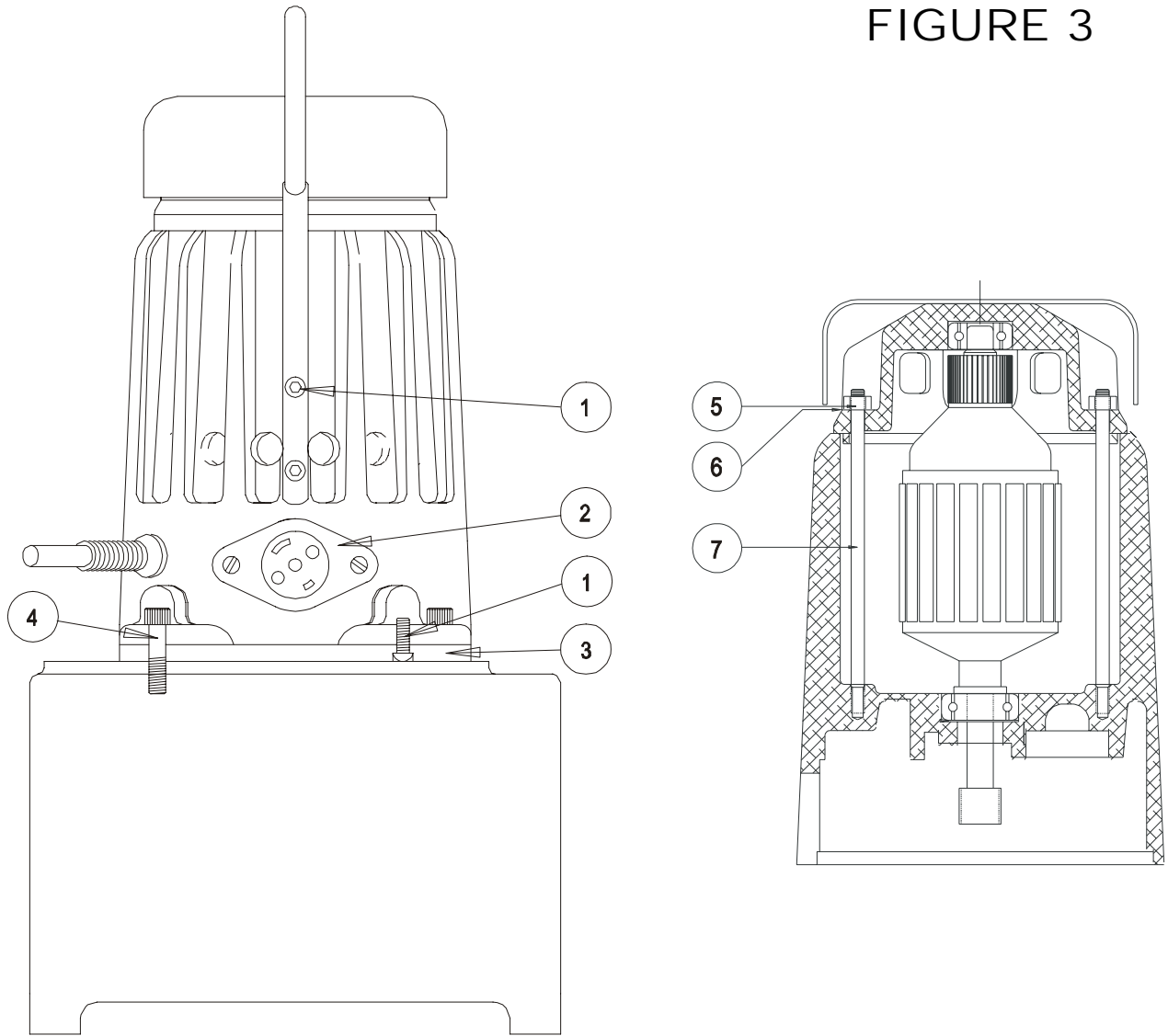

FIGURE 2



REF.	PART	QTY.	DESCRIPTION
1	R22003	1	MOTOR HOUSING
2	R22075	1	SIGHT GLASS
3	R22087	1	MANIFOLD BLOCK
4	R22070	1	TOGGLE SWITCH
5	R22062	1	VENT
6	R22006	1	RESERVOIR
7	1915-PS	1	REMOTE HAND CONTROL SWITCH (ABOVE)
8	R22086	1	ELECTRIC CORD SET (ABOVE)

FIGURE 3



REF.	PART	QTY.	DESCRIPTION (FIGURE 3)
1	R22058	8	BUTTON HEAD SET SCREW, 10-32X1/2
2	R22071	1	REMOTE SWITCH PORT
3	R22005	4	GEAR CASE COVER
4	R22096	1	SOCKET HEAD CAP SCREW, 1/4-20X1
5	R22078	4	HEX NUT
6	R22079	4	LOCK WASHER
7	R22076	2	STUD, BELL HOUSING

**FIGURE 4
MOTOR
ASSEMBLY**

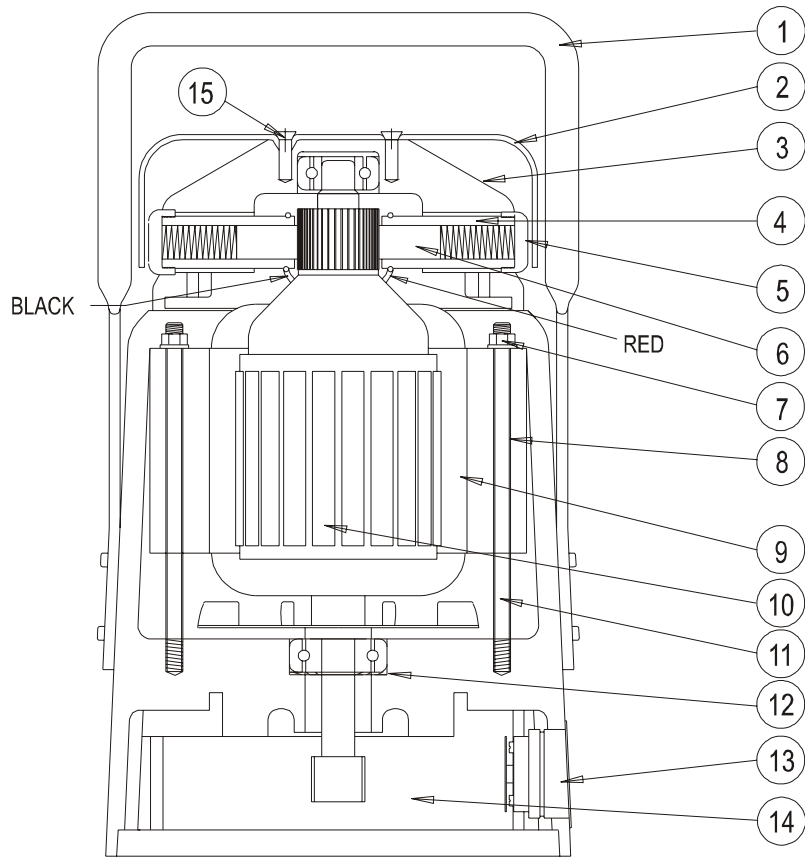

REF.	PART	QTY.	DESCRIPTION
1	R22050	1	HANDLE
2	R22065	1	BELL COVER
3	R22004	1	END BELL
4	R22062	2	BRUSH HOLDER
5	R22073	2	CAP, BRUSH HOLDER
6	R22068	2	BRUSH ASSY
7	R22078	4	10-32 HEX NUT & # 10 LOCKWASHER
8	R22085	2	PLASTIC TUBING
9	R22007	1	FIELD ASSY
10	R22008	1	ARMATURE ASSY
11	R22077	2	10-32 X 3 3/4 STUD
12	R22046	1	FINGER WASHER
13	R22071	1	RECEPTACLE
14	R22005	1	COVER
15	R22099	2	SCREW, 6-32 X 1/2 FHCS

FIGURE 5 PUMP BLOCK ASSEMBLY

REFER TO
FIGURE 6
(Balloon 11)

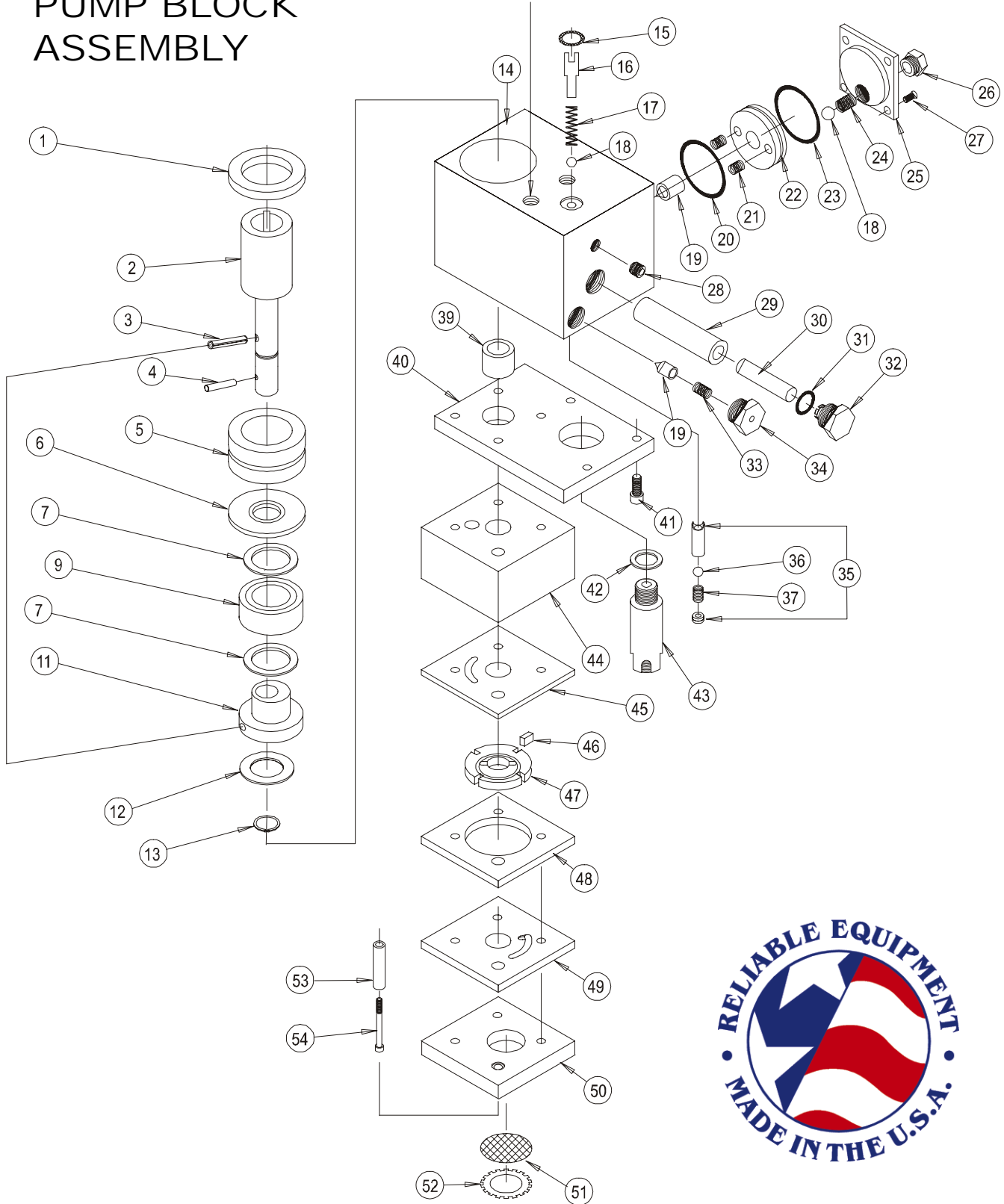

REF.	PART	QTY.	DESCRIPTION (FIGURE 4)
1	R22017	1	SPACER, BEARING
2	R22016	1	DRIVE SHAFT
3	R22024	1	3/16 ROLL PIN
4	R22030	1	1/8 X 3/4 DOWEL
5	R22018	1	BEARING, DRIVE SHAFT
6	R22019	1	LG. THRUST WASHER
7	R22020	2	CAM SPACER
9	12737	1	CAM BEARING ASSY
11	R22023	1	CAM
12	R22019	1	THRUST WASHER
13	R22041	1	RETAINING RING
14	R22009	1	INTENSIFIER BLOCK
15*	R22047	1	O-RING
16	R22026	1	PIN, BALL STOP
17	R22051	1	SPRING
18	R22054	2	1/4 DIA. BALL
19	R22061	2	VALVE PLUNGER
20*	R22052	1	O-RING,
21	R22056	2	SPRINGS, LP PISTON
22	R22048	1	LP RELIEF PISTON
23*	R22063	1	O-RING
24	R22060	1	LP SPRING
25	R22057	1	LP VALVE CAP
26	R22053	1	LP VALVE BODY
27	R22099	4	6-32 X 1/2 FHSS
28	R22079	1	1/16 NPT PLUG
29	R22036	1	BUSHING, HP
30	R22037	1	PISTON, HP
31*	R22049	1	O-RING
32	R22038	1	PRESSURE CAP
33	R22060	1	LP SPRING
34	R22040	1	LP VALVE CAP
35	R22035	1	SLEEVE & PLUG
36	R22069	1	3/16 DIA, BALL
37	R22055	2	PRESSURE RELIEF SPRING
39	R22028	1	NEEDLE BEARING
40	R22066	1	5/16 COVER PLATE
41	R22098	3	8-32 X 5/8 SHCS
42	R22081	1	COPPER WASHER
43	12780	1	HP RELIEF VALVE
44	R22046	1	SPACER BLOCK
45	R22029	1	OUTLET PLATE
46	R22032	4	VANE
47	R22031	1	ROTOR
48	R22033	1	CENTER PLATE
49	R22034	1	INTAKE PLATE
50	R22088	1	FILTER PLATE
51	R22089	1	SCREEN
52	R22093	1	RETAINING RING
53	R22095	1	LOCATING FERRULE
54	R22094	4	8-32 X 2 1/4 SHCS
*	R22100	1	SEAL KIT INCL. ITEMS INDICATED (see also #3 next page)

FIGURE 6

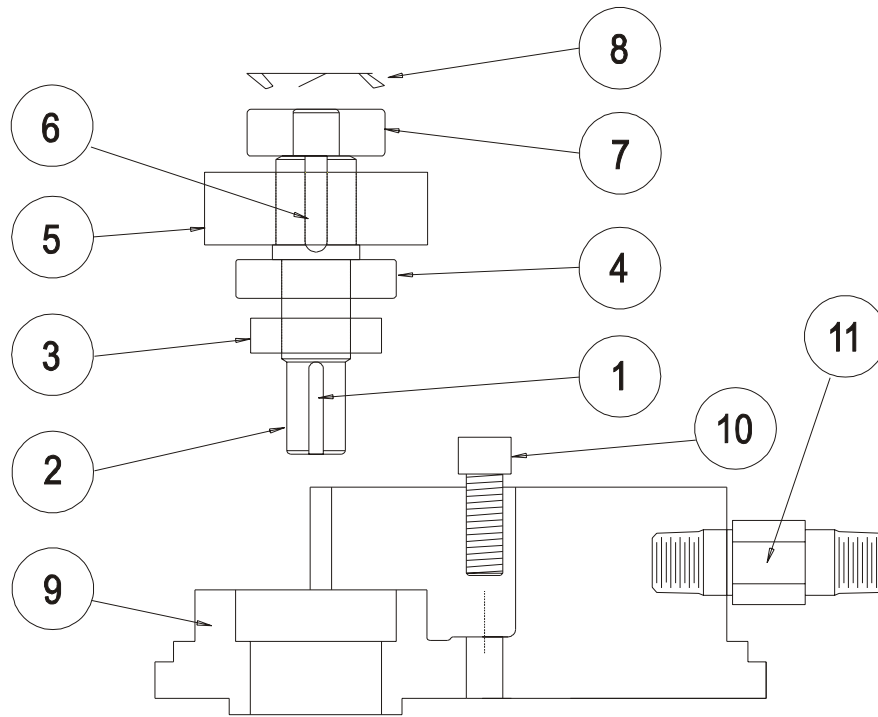

GEAR CASE COVER ASSEMBLY

REF.	PART	QTY.	DESCRIPTION (FIGURE 5)
1	R22074	1	COUNTER SHAFT
2	R22027	1	KEY
3*	R22010	1	SEAL SLEEVE (included in seal kit)
4	R22012	1	LOWER SHAFT BEARING
5	R22013	1	HELICAL GEAR
6	R22014	1	3/16 SQ X 1/2 LG KEY
7	R22011	1	UPPER SHAFT BEARING
8	R22046	1	FINGER WASHER
9	R22005	1	COVER
10	R22102	2	5/16 SOCKET HEAD CAP SCREW
11	R22045	1	PRESSURE PIPE, OUTLET



RELIABLE EQUIPMENT & SERVICE CO., INC.

REL-DIR-VALVE - BI-DIRECTIONAL VALVE

Converts your 10,000 PSI power source for multiple tool connections

* REL-DIR-VALVE



The **REL-DIR-VALVE** will save time, and reduce the need for continuous tool change-outs in repetitive or multiple tool operations. With this multi-tool converter all you do is turn the handle to switch the active tool.

For use on **RELIABLE'S** line of high pressure Pumps and Intensifiers.



* Fittings may vary to meet customer requirements.

FIGURE 7
REL-DIR-VALVE
MULTIPLE TOOL
SELECTOR VALVE

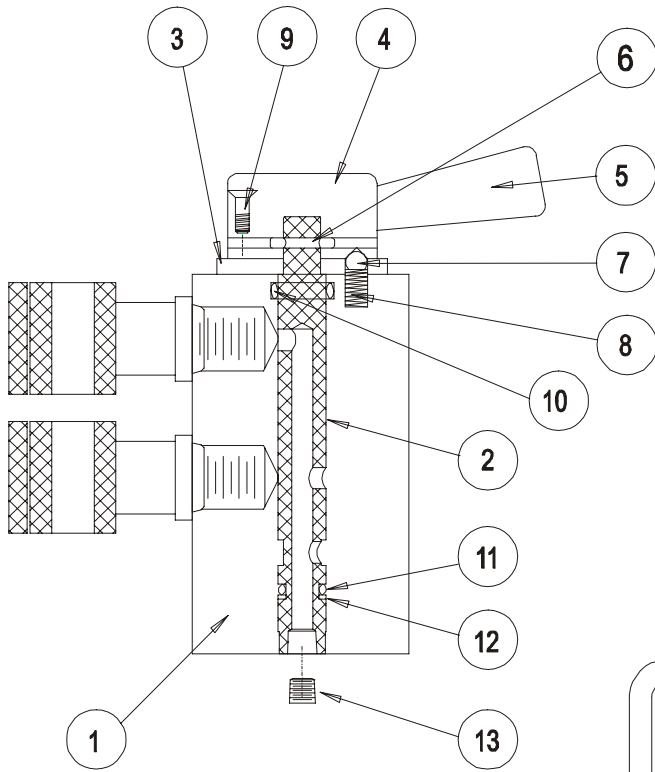

* Fittings may vary to meet customer requirements.

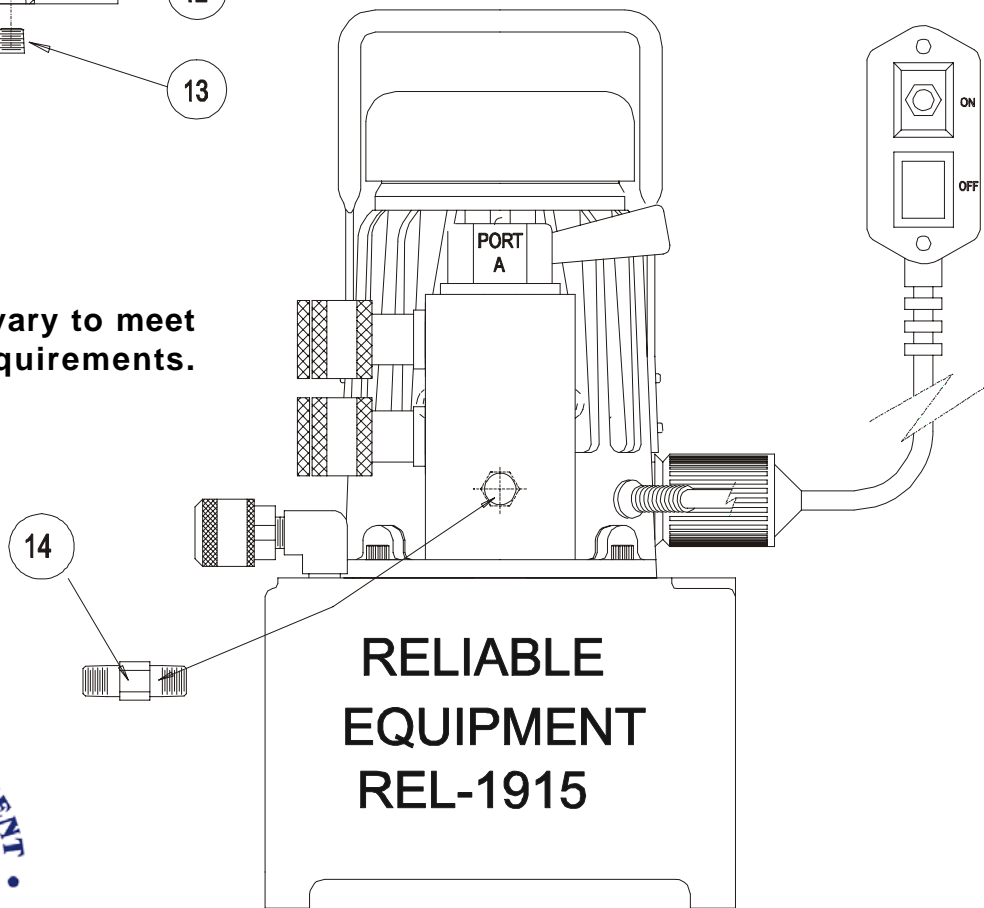

REF.	PART	QTY.	DESCRIPTION (FIGURE 7)
1	R22501	1	VALVE BODY
2	R22502	1	SPOOL
3	R22503	1	TOP PLATE
4	R22504	1	CAP
5	R22505	1	HANDLE
6	R22506	1	SPRING PIN
7	R22507	1	HARD BALL
8	R22508	1	COMPRESSION SPRING
9	R22509	4	FLAT HEAD SOCKET SCREW
10*	R22510	4	TOP SEAL, O'RING
11*	R22511	1	LOWER SEAL, O'RING
12*	R22512	1	BACKUP RING
13	R22513	1	1/16 NPT PLUG
14	R22514	1	OUTLET NIPPLE, 1/4 NPT
	K2251	1	SEAL KIT

* ITEMS INCLUDED IN SEAL KIT

MAINTENANCE RECORDS

Date	Parts or Service Required

If you have any questions regarding the information found in this manual please contact RELIABLE EQUIPMENT at the address, phone or fax numbers shown below.



92 Steamwhistle Drive • Ivyland, PA 18974
Phone: 800-966-3530 • Fax: 215-357-9193
Visit us on the web at www.Reliable-Equip.com