

# OPERATORS' GUIDE

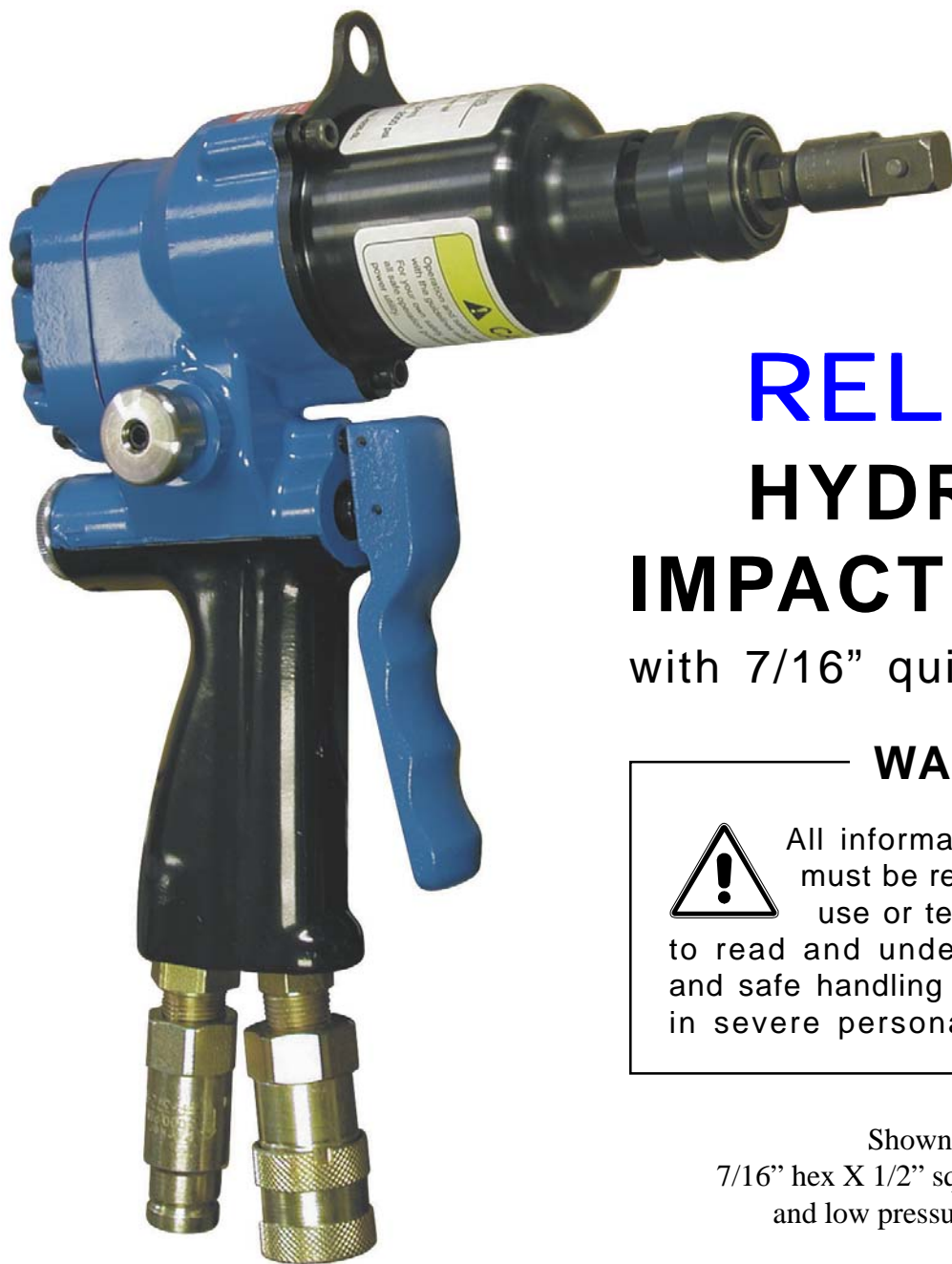

## REL-425C HYDRAULIC IMPACT WRENCH

with 7/16" quick change chuck

### WARNING



All information found in this guide must be read and understood before use or testing of this tool. Failure to read and understand these warnings and safe handling instructions could result in severe personal injury and or death.

Shown with optional  
7/16" hex X 1/2" square drive impact adapter  
and low pressure hydraulic couplers

DISTRIBUTED BY



# RELIABLE EQUIPMENT & SERVICE CO., INC.

REL-425C Manual 03-09

# DISTRIBUTED BY

## REGISTRATION

UPON RECEIPT OF THIS TOOL, COMPLETE THE REGISTRATION BELOW.

COMPANY \_\_\_\_\_

ADDRESS \_\_\_\_\_

\_\_\_\_\_

PHONE \_\_\_\_\_ FAX \_\_\_\_\_

SERIAL NUMBER \_\_\_\_\_

DATE OF PURCHASE \_\_\_\_\_

DEALER NAME \_\_\_\_\_



**THIS SYMBOL INDICATES ITEMS OF EXTREME IMPORTANCE.**

Safety of user and others may be in jeopardy if these instructions are not read and understood.



CAUTION

The information in this manual is intended to guide the user in the use and application of this tool. It is not intended as a substitute for proper training and experience in safe work practices for this type of equipment.

Consult your supervisor or safety personnel if you have any questions regarding the safe operation of this tool.

# TABLE OF CONTENTS

<b>DESCRIPTION</b> .....	<b>3</b>
<b>TOOL SPECIFICATIONS</b> .....	<b>4</b>
<b>SOURCE SPECIFICATIONS</b> .....	<b>4</b>
<b>GENERAL SAFETY INFORMATION</b> .....	<b>5-7</b>
<b>HOSES - Fittings, Connections, Installation</b> .....	<b>8</b>
<b>HOSES AND FITTINGS (General Information)</b> .....	<b>9</b>
<b>OPERATIONAL SAFETY</b> .....	<b>10</b>
<b>OPERATING INSTRUCTIONS</b> .....	<b>11</b>
<b>MAINTENANCE</b> .....	<b>12</b>
<b>DISASSEMBLY</b> .....	<b>13-14</b>
<b>ASSEMBLY</b> .....	<b>15-19</b>
<b>PARTS DIAGRAM REL-425</b> .....	<b>20</b>
<b>PARTS LIST FOR REL-425</b> .....	<b>21</b>
<b>PARTS LIST FOR PRESSURE CONTROL SPOOL</b> .....	<b>22</b>
<b>INTRODUCTION &amp; SPECIFICATIONS FOR REL-425C</b> .....	<b>23</b>
<b>PARTS DIAGRAM REL-425C</b> .....	<b>24</b>
<b>PARTS LIST FOR REL-425C</b> .....	<b>25</b>
<b>PARTS LIST REL-425C O/C CONTROL SPOOL</b> .....	<b>26</b>
<b>USING REL-425TS (TEST STAND)</b> .....	<b>27</b>
<b>MAINTENANCE RECORD</b> .....	<b>28</b>

## DESCRIPTION

The REL-425C is a user friendly hydraulic impact tool that has broad applications for the utility and construction industries. Delivering 425 ft. lbs. of torque at 6 gpm, this tool is great for drilling, loosening rusted hardware, or tightening lag bolts with ease.

The tool is well balanced to feel comfortable and secure. The trigger is designed to be responsive in a heavily gloved hand enabling the user smooth, easily controlled operation. The dual system actuating spool can be switched from open center to closed center by simply turning the selector knob completely. A readily accessible reversing spool allows unconstrained direction control. The handle is coated with a heat protecting material which aids in handling the tool in adverse conditions.

The REL-425 comes with the standard 7/16" hex in the nose with an E-Z grip quick-release chuck to readily change from square adapters for sockets to various tools such as drills and augers.

# TOOL SPECIFICATIONS

Length .....	8.6" (21.8cm)
Width .....	2.7" (6.8 cm)
Height.....	8.8" (21.8 cm)
Weight .....	6.3 lb. (2.8 kg)
Output Torque .....	425 ft lb. @ 5-6 gpm (recommended)
<b>NOTE: TORQUE MAY VARY WITH TRUCK PRESSURE AND HYDRAULIC FLOW</b>	
Pressure Port .....	9/16-18 SAE Thread
Return Port .....	3/4-16 SAE Thread
Drive .....	7/16 Hex Socket (Removable 1/2" Sq. Drive)
Hyd. System Type .....	E-Z Open and Closed Center

## SPECIFICATIONS

### Hydraulic Power Source

Flow:	Min. ....	4 gpm (5.1 lpm)
	Recommended .....	5-8 gpm (19-30 lpm)
	Flow Range.....	4-8 gpm (15-45 lpm)
	Optimum Flow .....	6 gpm* (12.7 lpm)
RPM .....		3,600 @ 6 gpm
Operating Pressure Min. ....		1,300 psi (69 bar)
Operating Pressure Max. ....		2,000 psi (138 bar)
Pressure Relief Setting.....		2,000 psi Max. (138 bar)
Back Pressure .....		200 psi (13.8bar)
Filtration .....		10 microns Max.
Hydraulic System .....		E-Z Select for Open or Closed Center
Fluid Temperature, Max.....		140° F (60° C)

\* Checked with Flowmeter on Pressure Line



WARNING

Relief Valve not to exceed 2000 psi

Flow not to exceed 8 gpm



**WARNING**

**BEFORE USING THIS TOOL, READ THE WARNINGS and the recommended practices described in this manual. Failure by the operator to read and fully understand these warnings will leave this person unqualified to use and operate this tool. Property damage, severe personal injury, and/or death could result by not following these warnings.**

These warnings will appear in appropriate locations when they are pertinent to the particular subject being shown. Read each one carefully and follow them strictly.



### **Eye Protection**

**WARNING**

**Always wear eye protection to avoid injury from flying debris or hydraulic oil leaks. Failure to do so can result in serious personal injury.**



### **Dust Mask**

**WARNING**

**Always wear a dust mask. Failure to observe this warning may result in serious health issues and/or breathing difficulty.**



### **Hard Hat**

**WARNING**

**Always wear a hard hat to avoid injury from falling debris. Failure to do so can result in serious personal injury.**



### **Foot Protection**

**WARNING**

**Always wear foot protection. Failure to do so can result in serious personal injury.**



### **Hearing Protection**

**WARNING**

**Always wear hearing protection, to avoid hearing loss due to long term exposure to high noise levels.**



### **Protective Gloves**

**WARNING**

**Always wear protective gloves. Failure to do so can result in serious personal injury.**



WARNING

## Safe Operation & Care

**USE THIS TOOL FOR ITS INTENDED PURPOSE ONLY**

Any other use can result in injury or property damage.

**INSPECT TOOL BEFORE USE.** Replace any worn, damaged or missing parts. A damaged or improperly assembled tool may malfunction, injuring operator and/or nearby personnel.

**INSPECT HYDRAULIC HOSES AND COUPLINGS** before each use. Repair or replace if any cracking, leakage, wear or damage is found. Worn or damaged hoses may fail resulting in personal injury or property damage.

**CLEAR WORK AREA** of all bystanders and unnecessary personnel before operating this tool.

**KEEP ALL PARTS OF THE BODY AWAY FROM MOVING PARTS.**

Failure to observe this warning could result in serious injury.



WARNING

## Safety

**DO NOT** attempt to make any changes to any of the component parts or accessories when connected to the power source.

**DO NOT** adjust, inspect, or clean tool while the tool is connected to the power source. The tool could accidentally start up and cause serious injury.

**DO NOT** lock the tool in the On Position. In an emergency, serious damage or injury could occur during the time required to stop the tool.



WARNING

## Oil Injection Injury

Hydraulic oil or fluid under the skin is a serious injury. Oil under pressure can penetrate the skin and may cause dismemberment or loss of life. Seek medical assistance immediately if such an injury should occur.

Always wear safety gloves, eye protection and all required safety equipment when operating or handling this tool.

**DO NOT** use fingers or hands to attempt to locate a leak.

**DO NOT** handle hoses or couplers while system is pressurized.

**NEVER** open or service the system before depressurizing.



WARNING

## Burn Hazard

**Do Not** connect or disconnect tool, hoses or fittings while power source is running or while hydraulic fluid is hot. Hot hydraulic fluid may cause serious burns.

Failure to observe this warning could result in serious injury.



WARNING

## Electrical Shock Hazard

Use only certified nonconductive hoses and fittings. Always wear and use the necessary clothing, equipment and safety practices to protect against electrical shock. Failure to follow these rules can result in serious personal injury or death.



CAUTION

## Vibration Hazard

Apply just enough pressure to control the tool operation. Applying excess pressure to the tool may cause operator discomfort or temporary numbness.

Failure to observe this warning could result in serious injury.



CAUTION

## Safe Handling

**HYDRAULIC FLUID MAY CAUSE SKIN IRRITATION.**

Prevent hydraulic fluid from making contact with skin.

**IN THE EVENT OF SKIN CONTACT** immediately wash thoroughly.

Failure to observe this warning could result in injury.



CAUTION

## General Safety

Ensure that all fellow employees and bystanders are clear and protected from possible injury caused by this tool or the operations being performed. Persons in close proximity could be injured and property damaged if the tool were to malfunction.

This tool should always be used within the limits and purposes stated by the product manufacturer. Abuse or usage beyond the manufacturers' intended purposes could cause damage to the tool and severe injury to the operator.



WARNING

## HOSES AND FITTINGS

There exists the potential for shock in using anything other than certified nonconductive hoses and hydraulic oil with dielectric properties, when using system components near energized electrical lines. Failure to recognize these conditions could cause electrocution.

**Hoses and fittings used with this tool must comply with S.A.E. J1273** which covers recommended practice for selection, installation, and maintenance of hose and hose assemblies. The **correct hoses and fittings are available from your supplier.**

**WARNING:** Failure to comply with these warnings could result in severe bodily injury.



WARNING

## UNIT/HOSE CONNECTIONS

**ALWAYS SHUT OFF** pump/power source and move flow selector to **OFF** before connecting or disconnecting system components.

**ALWAYS DEPRESSURIZE** hydraulic system before slowly disconnecting this unit or any of the systems components.

**ALWAYS TIGHTEN** couplings completely. Loose or improperly tightened couplings will not allow fluid to pass through the hose creating a blockage in the supply or return line.

**ALWAYS INSPECT HOSES AND CONNECTORS** before connection to tool. Replace or repair if any leakage is evident. Leakage is a sign of deterioration in component parts. Worn or leaking parts must be repaired or replaced, or tool damage or severe injury could result.



CAUTION

## HOSE INSTALLATION

Care must be taken to assure the correct connection of the hoses to the pressure and return ports.

**Connect the return hose to the return port on the power source, then to the return port on the tool.**

**Connect the pressure hose to the pressure port on the tool, then to the pressure port on the power source.**

Operation with hydraulic flow reversed can cause malfunction. Failure to fully comply can result in severe injury or death.

# HOSES AND FITTINGS

**Care must be exercised in the use of hose and fittings** for use on hydraulic tools, especially in confined areas. Any obstruction or abrasive surrounding could damage the hose and cause a serious accident. Always use the recommended hose for the tool that is being used. Always consult the dealer or distributor for the correct hoses and purchase from him to ensure, from a safety standpoint that the materials used in the manufacture of the hoses is to the correct specification for the application. Fittings must meet the standards established by the industry to adequately assure safety. Poor quality or low rated fittings are not to be used. They invite a serious accident.

**Length:** Hose must be the correct length for the general use of the tool or for the specific function it is to provide. Pressure surge is an important factor in the selection of hoses. The hose should be rated above the expected surge pressure to ensure adequate safety. Hoses that are too long will have a tendency to coil, kink, or move in multiple directions creating a safety hazard. Hoses that are too long will rub or chafe against the ground or projecting objects, seriously shortening the life of the hose. It may be advisable to carefully restrain a hose which is temporarily too long for the current application. Pressure surge can cause whipping, and seriously damage the hose. Always keep the hose length as short as possible for the operation which is it intended.

**Size:** The hose must be large enough to carry the pressurized flow of fluid to the end application without creating undue heat generation or excessive turbulence. These factors could cause excessive wear to the hose from any or all of the above reasons.

**Pressure:** Hose selection must be made so that the *recommended maximum operating pressure is greater than the system pressure*. A surge or sudden drop in pressure will cause the hose to deteriorate faster if the maximum pressure of the hose is significantly below the surge pressure. A hose with a top rate of pressure as the line pressure of the installation is not an accepted safety practice. Always err on the side of safety.

**Temperature:** Hose can be seriously damaged by passing over or near hot objects. Avoid any situation that will heat the hose. Serious damage and/or failure will occur.

**Unusual Applications:** Careful thought and research should precede installation of hoses. Thorough and protected testing, with appropriate safety guards, must be done to avoid injury before general use.

**Connections:** Hoses must have the proper end fittings in order to mate correctly with connectors. Worn or damaged connectors and worn end fittings on the ends of the hose can cause a failure. Pressure surge can cause a slow or sudden failure at the connection causing serious damage or injury.

**Safety Check:** Before using any installation, perform a thorough checkout to determine if any of the above or unforeseen problems occur. Initial testing with safety guards is an invaluable safety precaution.

**Always consult** the distributor or manufacturer for the correct specifications regarding any of the items discussed above. **The correct hoses and fitting are available from your supplier.**



**WARNING**

There exists the potential for **SHOCK** in using anything other than certified non-conductive hoses and hydraulic oil with dielectric properties when using system components near **ENERGIZED ELECTRICAL LINES**. Failure to recognize these conditions could cause **ELECTROCUTION**.

Hoses and fittings used with this tool must comply with **S.A.E. J1273** recommended practice for selection, installation, and maintenance of hose assemblies.

**FAILURE TO COMPLY WITH THESE WARNINGS COULD RESULT IN SEVERE BODILY INJURY.**



**WARNING**

Operation/Safety methods may vary in accordance with the working guidelines established by each utility or contractor.

For your own safety, ensure that you fully comply with all safe operation guidelines required by your employer.

## **OPERATIONAL SAFETY WARNINGS**

**SHOCK, ELECTRICAL:** This is a non-insulated tool. The need for keeping the tool dry and clean is imperative. Using this tool in an energized electrical environment could be dangerous to the user. Failure to take this into account could result in electrocution.

**NEVER CONNECT** components or fittings to this unit unless power/pump source is turned off or disconnected.

**ALWAYS INSPECT** hydraulic hoses and fittings for wear or deterioration every day. Replace all parts that show signs of leaking, wear, or damage.

**KEEP ALL PARTS OF THE BODY AWAY** from moving parts of the tool when connected to the power source for the tool.

**MAKE SURE** there is no person in close proximity to you or the tool who could be injured by any operation being performed with the tool.

**DO NOT** overextend your position by overreaching or unbalancing the footing necessary to maintain physical control of your body.

**ALWAYS MAINTAIN** a firm grip on the tool to avoid having the tool slip out of the hands during an operation, causing a serious injury.

**DO NOT** side load or apply any type of indirect force.

Socket, bit, or adapter may be damaged creating a potentially dangerous situation.

**DEPRESSURIZE THE UNIT** before attempting to disassemble, connect, or disconnect any of the components. Check oil temperature before disconnecting or disassembling this unit. A serious burn could result from this exposure.

**SEE A DOCTOR IMMEDIATELY**, if a hot oil injury should occur.

**SEE A DOCTOR IMMEDIATELY**, if a pressurized oil injury should occur. Infection or serious reaction could result from any hydraulic pressure injury.

**USE THIS TOOL FOR THE MANUFACTURERS' INTENDED PURPOSE ONLY.**

**USE ALL APPROPRIATE AND APPLICABLE PERSONAL SAFETY EQUIPMENT** as required by the operating company.

**OBSERVE CLOSELY ALL SAFETY RULES FOR A PARTICULAR JOB CLASS**

**THE PURCHASER/OWNER** of this unit must be certain that all the users of this unit are properly trained in its use and in compliance with all appropriate industrial codes and/or practices.

**FAILURE TO HEED THESE WARNINGS COULD RESULT IN  
SERIOUS PERSONAL INJURY AND/OR PROPERTY DAMAGE.**

# OPERATING INSTRUCTIONS

## Correctly install fittings

1. Although the tool will work with the pressure and return lines backwards, the tool's performance will be adversely affected and this may create an unsafe condition in certain hydraulic systems. The pressure inlet is the smaller forward port. A 9/16–18 SAE fitting (Parker #6) is required. The return outlet requires a 3/4-18 SAE fitting (Parker #8.)
2. At this point, it is important to ensure that any couplers used are the correct type, and the flow is going in the right direction.

## Select Open-Center or Closed-Center NEW O/C SPOOL DESIGN

**IMPORTANT!** The operator of the tool MUST know the type of hydraulic system on which the tool is being used. Failure to observe all warnings and instructions could result in property damage, severe personal injury, and/or death.

The O/C knob has been engraved with an arrow indicating the direction for the appropriate OPEN/Closed Center setting.

**The O/C spool has been pre-set to an OPEN CENTER configuration at the factory.**

To Change spool setting for CLOSED CENTER operation: Turn O/C knob in the Clockwise direction. (Turn O/C knob completely) **HAND TIGHTEN ONLY**

**NOTE:** While using the tool, the operator should check the OC/CC alignment frequently in the event it becomes inadvertently disoriented.

## Installing a driver or drill into the chuck



WARNING

**USE ONLY IMPACT STYLE BITS, SOCKETS AND ACCESSORIES APPROVED FOR IMPACT USE.** Bits, sockets, and accessories not designed for impact applications can break and cause severe injury.

**INSPECT BITS, SOCKETS AND ACCESSORIES BEFORE USE.**

Discard damaged items. Damaged items can break and cause severe injury.

1. Ensure the power supply is disconnected. Squeeze the trigger to relieve any internal pressure.
2. Pull the chuck away from the front end of the REL-425 as far as it will go.
3. Slide the bit into the anvil. **Wear protective gloves: drill bits may cause injury.**
4. Release the chuck and ensure it snaps back into position. Check that the bit is being held securely in place.

## Using the REL-425

1. Before placing a load on the tool, squeeze the trigger a few times to ensure the wrench will start and stop correctly and the bit is turning in the right direction.
2. If the inlet and outlet lines are correct and the reversing spool is pushed toward the right, the anvil should turn clockwise. Check to be sure that the reversing spool is all the way toward the right or left as needed.
3. The trigger is designed to make it easy to “feather” the REL-425. For safest operation, squeeze and release the trigger slowly.
4. When the tool is not in use, remove it from the power source.

# MAINTENANCE

The life, reliability, and safety of the tool is dependent on proper maintenance.

## DAILY MAINTENANCE

**Clean** all surfaces including handle, trigger, chuck, main spool, reversing spool, fittings, and hoses.

**Inspect** tool for wear and damage.

Worn or damaged parts can cause malfunction during operation.

Inspect for cracked hoses and leaking fittings.

**Check** fluid level of the power source reservoir frequently.

**All the above items must be replaced with new parts if signs of wear are evident.**

**FLUID CONTAMINATION:** Cover the ends of fittings with a dust cap when disconnected. This will help keep the fluid from contamination.

**MONTHLY MAINTENANCE:** Inspect per Appendix A, SAE Standard J1273, 5/86 for hose or fitting damage such as wear, cracks or leakage, replace the necessary parts.

NOTE: Keep Label Set clean and legible. Replace decals when necessary. Part #RL13100



**WARNING**

BEFORE USING THIS PRODUCT READ THE SAFETY WARNINGS and recommended practices described in the manual. Failure by the operator to read and fully understand the warnings will leave this person unqualified to use and operate the tool.

Failure to observe all warnings and instructions could result in property damage, severe personal injury, and/or death.

**SPECIFICATIONS**

Chuck: 7/16 quick change  
 System: open or closed center  
 Flow Range: 4 - 8 gpm  
 (optimum 6 gpm)  
 Operating Pressure: 1000-2000 psi

REL-425B-SL

**CAUTION**

Operation and safety methods may vary in accordance with the guidelines established by each utility. For your safety, ensure that you fully comply with all safe operation guidelines established by your respective power utility.

REL-SM

**DANGER**

The user should be properly trained in the correct procedures required for work on or around electrical lines.

# HYDRAULIC FLUIDS

All hydraulic fluids that meet these listed specifications or the listed HTMA specifications may be used for this tool.

## S. U. S.

@ 100° F (38° C) ..... 140 TO 225

@ 210° F (99° C) ..... 40 minimum

**FLASH POINT** ..... 340° F min. (170° C min.)

**POUR POINT..** ..... -30° F min. (-34° C min.)

# DISASSEMBLING THE REL-425

## ALWAYS WEAR EYE PROTECTION!



WARNING

Before beginning any repair, the tool must be removed from the power source and the internal oil pressure must be relieved. Gloves and face protection should be worn. Carefully remove the inlet and outlet fittings. Squeeze the trigger and hold for a few seconds, then switch the reversing spool to the other direction and hold the trigger open again.

**NOTE:** Complete disassembly should be performed by factory authorized personnel only! Refer to the parts drawing while following these instructions.

## REMOVING THE TRIGGER

1. Place a solid support under the trigger while driving the two pins (37) out from the trigger nuts. **CAUTION:** Failing to properly support the trigger may break the body casting or bend the main spool (14.)
2. Remove the trigger nuts (5.)

## REMOVING THE CHUCK

1. Remove the front ring clip (66) from the anvil. **CAUTION:** the ring clip may fly off and strike you or someone standing nearby, and the cap (65) and spring (64) will want to shoot out when released. Take precautions to prevent these parts from becoming projectiles.
2. As you slide the nose piece (63) off the anvil, the two bearings (67) may drop out. If required, for further repair, remove the inner ring clip.
3. Examine the parts carefully and replace any worn or damaged parts. Ensure the ring clips were not deformed during removal. If in doubt, replace them.

## Disassembling the Impact Housing

1. Disassemble on a clean flat surface. Remove the three socket head screws (26.) Pull the shell (60) away from the body being careful not to loose any parts that may fall out. The cage (61) with the two hammers (50) and hammer pins (69) will drop off of the anvil. Take note of how the two identical hammers are set in the opposite direction of each other. During re-assembly it will not matter which way they go as long as they are 180° apart.
2. The large pin washer (68), spacer (44), and the thrust washers (10) and bearing (11) can be removed from the body.

## Removing the Reversing Spool

**Note:** The spool can be installed or removed from either side.

1. Remove both adjusting caps (82) from the reversing spool. **CAUTION:** do not use pliers. to hold the spool while loosening a screw.
2. Push the spool into one side of the body until the O-ring is exposed on the other side.
3. Remove the exposed O-ring.
4. Push the spool back in the opposite direction all the way out of the body. *Do not attempt to push an O-ring all the way through the body.*

## Disassembling the Motor

**NOTE:** Oil will run out when the cap is loosened.

1. Remove the eight socket head screws (28) from the back of the motor cap.
2. Pull the cap back just enough to drain the oil into a proper receptacle.
3. Pull the cap all the way off taking care not to lose any of the parts that may fall out.
4. Remove the idler shaft (40), pin (41), and lower gear.
5. Remove the circle clip (13) and upper gear.
6. The drive shaft can be pushed out through the front of the tool. Do not attempt to pull the drive shaft back through the motor end.
7. Examine the five needle bearings (30) in the body and cap. If the bearings in the cap are damaged, replace the cap. A new cap is supplied with bearings pressed in. If the bearings in the body are damaged, return it to the factory for repair or replace the body with the bearings already pressed in.

## Disassembling the Main Spool

**Caution:** The main spool is spring loaded. Wear proper protection to prevent injury in the event you lose control of the parts.

1. Drive out the coiled spring pin (37) and remove the OC/CC knob (17).
2. Pull the spool back which will compress the spring and secure it. This can be done by sliding a thin O-ring pick through the hole where the coiled spring pin came out of and wedging it over the ear on the back of the body.
3. Remove the spring clip (16) and washer (17) from the trigger end.
4. Carefully release the main spool and allow the spring to decompress.
5. Remove the spring clip (16) and washer (17) from the back end.

**NOTE:** It is difficult to remove the two spring clips without damaging them. We recommend replacing the spring clips every time they are removed.

6. Pull the main spool out the back end of the tool. Do not pull the spool out the trigger end.

# REASSEMBLING THE REL-425C

**NOTE:** Before reassembling the REL-425C, inspect all parts for damage or excessive wear. Nicks or burrs on the corners of the shafts or spools can be fatal to tool life. All old grease should be removed and the parts should be clean and free of foreign particles. It is recommended to replace the O-rings, the circle clip, and, most importantly, the two spring clips (16) on each end of the main spool each time the unit is reassembled.

## REASSEMBLING THE MAIN SPOOL (AS REVISED 06/08)

1. Replace the O-ring inside the hand body. (Not shown in diagram below. See pg 22)
2. Replace the O-ring on the main spool.
3. Replace the O-ring on the spool stem.
4. Pre-lubricate the passageway where the spool resides and all spool components with petroleum jelly or hydraulic oil.
5. Reinstall brass pintle.
6. Thread stem into spool body completely. (Hand tighten only)
7. Insert retaining clip into main spool body
8. Insert flat washer and retaining ring into trigger side of handle body.

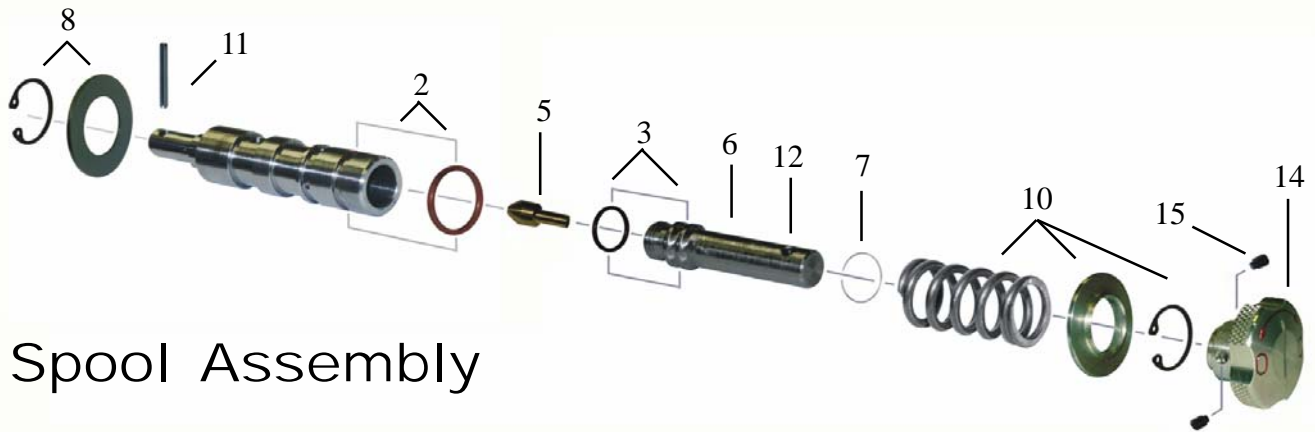

## Spool Assembly

9. Slide the spool into the back of the unit so that the narrow end with roll pin hole protrudes out of the front where the trigger attaches.
10. Insert trigger spring, support washer and retaining ring. Correct order is important.
11. **Re-connect trigger using long roll pin before installing O/C knob.**
12. Turn spool stem out until retaining clip stops progress.
13. Squeeze trigger fully and secure with roll pin hole exposed.
14. Install knob onto end of spool stem. Align roll pin hole with hole in the stem. (O/C marking orientation is not critical)
15. Using blue Loctite<sup>®</sup> install the set screws into OC/CC Knob. Align set screws with holes in spool body and tighten completely. (Do NOT over tighten)

NOTE: O/C Spool is now in the OPEN CENTER configuration. Adjust accordingly

## Reassembling the Motor

1. Replace the O-ring (35).
2. Apply petroleum jelly to the drive shaft to help it slide through the O-ring. Install the drive shaft. It will only go one way.
3. Install the Key (12). Petroleum jelly will keep it in place while installing the gear.
4. Install the upper gear (3).
5. Install the circle clip (13).
6. Assemble the lower gear (3), idler shaft (40), and it's pin (41) in their place.
7. Install the two dowel pins (31).
8. Install a new gasket (7).
9. Install the motor cap (6).
10. Install the eight socket head screws (28) as shown with their lockwashers (29).

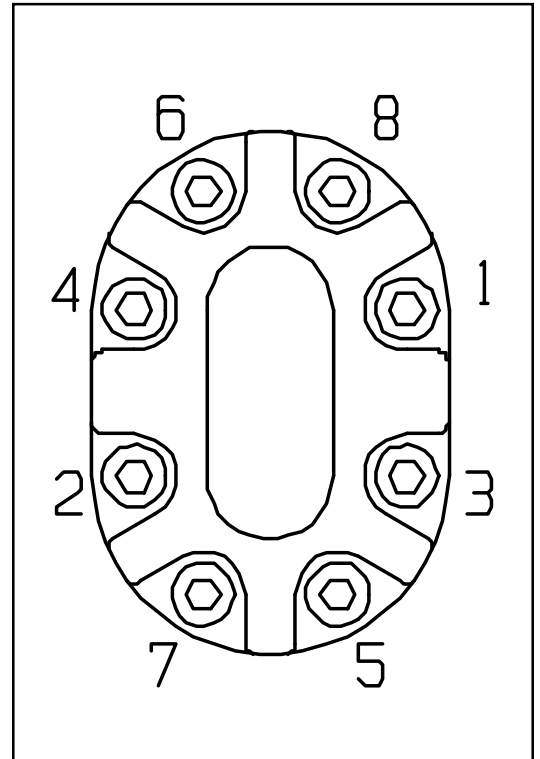

Replace any screw or lockwasher that appears defective.

A service removable liquid thread adhesive (e.g. blue Loctite®) is recommended.

First snug all screws, then torque in the sequence shown below to **80 in-lbs.**

## Reassemble the Trigger

1. Install the two trigger nuts (5). Screw the nuts all the way in, then back off approximately one turn.
2. Lay the unit on its side. Position the trigger over the nuts and place a support under the trigger.
3. Drive in the two coiled spring pins (37).

## Reassembling the Impact Housing

**NOTE:** Use a high quality lithium grease that is rated for at least 250° F. An HP or EP grease with an NGLI #2 rating is recommend.

1. Thoroughly grease the drive shaft (8).
2. Clean and inspect the thrust bearing (11) and two thrust washers (10) to ensure they roll freely. If in doubt, replace them. Repack the bearing with grease.
3. Install with the bearing between the two washers as shown in the parts list drawing by dropping the washer-bearing-washer over the drive shaft and into the pocket in the body.
4. Grease the inside of the spacer (44) and drop over the drive shaft.
5. Drop the pin washer (68) over the drive shaft so the raised boss is towards the spacer. Apply a light coating of grease to the face of the pin washer.

Set the body aside.

6. Thoroughly grease the inside of the anvil bushing (60) inside the shell (60), and install the anvil (62). Install adapter flange (70) into body (2) and work O-ring (71) into position around flange.
7. Reassemble the hammers (50) into the cage (61) using a light coating of grease over entire mechanism.

**NOTE:** The hammers must be turned 180° from each other. It does not matter which hammer points up or down as long as they are opposite. (Refer to illustration shown at right)

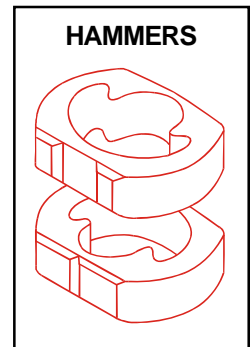

8. Install the long pins (69).
9. Apply a coating of grease to the anvil and insert into cage and hammer assembly.
10. Carefully add anvil and hammer assembly to body assembly. (*Support hammer pins*) Coat all moving parts liberally with recommended grease.

**DO NOT PACK NOSE ASSEMBLY WITH GREASE.** This can cause heat build up.

11. Install the shell over the hammer mechanism and onto the body.
12. Install and snug the three screws (26) and lockwashers (27). Use a removable liquid thread locking compound (e.g.: blue Loctite®).

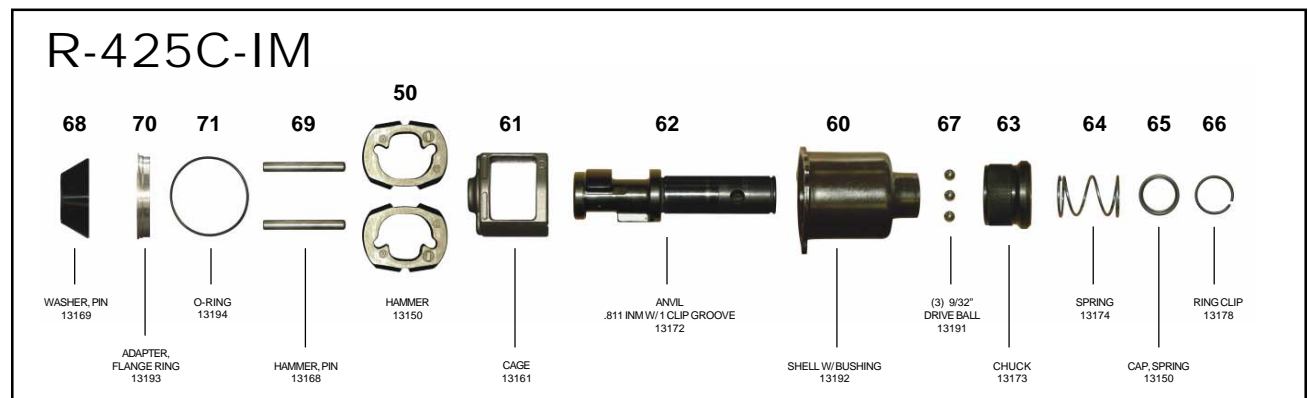

## Reassembling the Chuck

1. Install the drive balls (67).  
Filling the holes where the drive balls go with grease will hold them in place.
2. Wipe a thin film of grease over all the end of the anvil and install the chuck.
3. Insert the anvil spring (64).
4. Insert the spring cap (65) with the flat side toward the spring (see figure below).
5. Install the forward ring clip (66).

**WARNING: Wear face protection.**



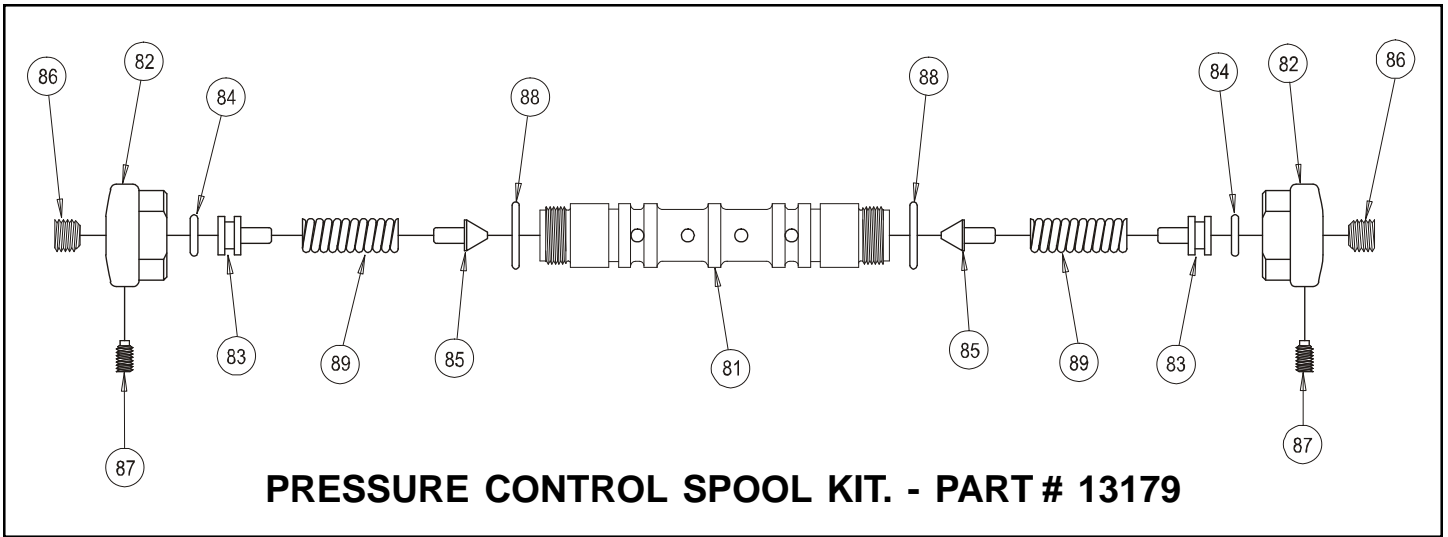

**PRESSURE CONTROL SPOOL KIT. - PART # 13179**

Item #	Description	Part Number	# Req.
81	SPOOL, REVERSING	13181	1
82	ADJUSTING CAP	13182	2
83	PLUG, ADJUSTING	13183	2
84 *	O-RING, PLUG (incl. in seal kit)	13184	2
85	PINTLE	13185	2
86	ADJUSTING SCREW, 5/16-24 FLAT POINT	13186	2
87	LOCK SCREW, 8-32 X 1/4 BRASS TIP	13187	2
88 *	O-RING, SPOOL (incl. in seal kit)	13188	2
89	SPRING	13189	2

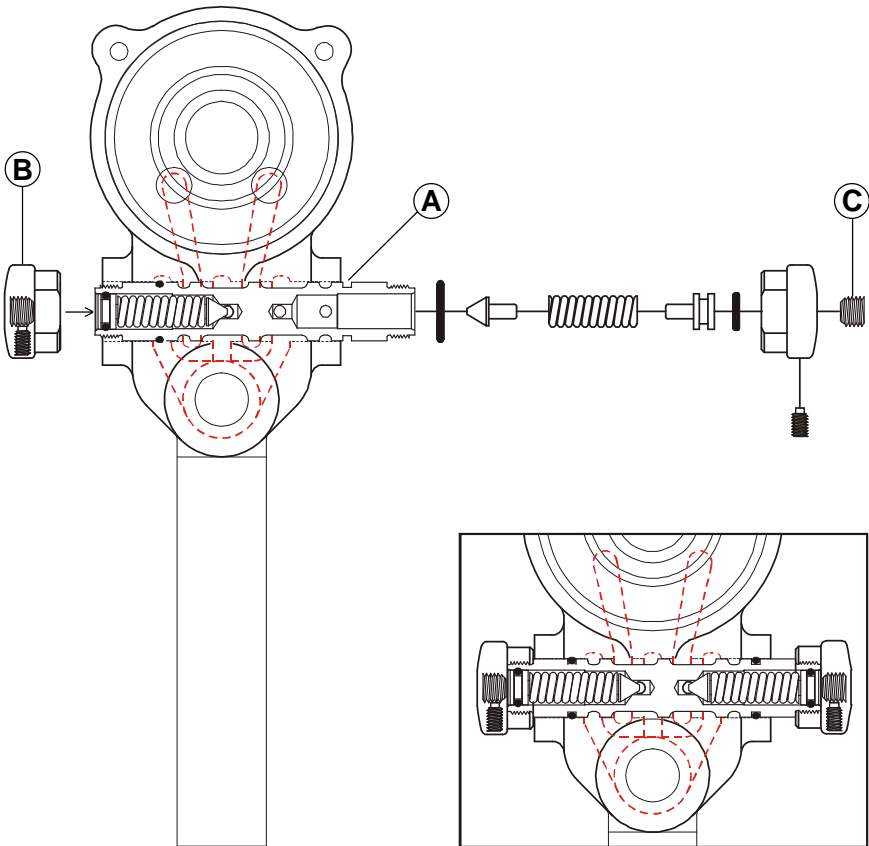

**PRESSURE CONTROL SPOOL ASSEMBLY**

Assemble the control spool as shown. Begin with left or right assembly.  
 NOTE: Do not install adjusting Cap (82)  
 Insert spool until O-ring groove (A) is seen. Install appropriate O-ring, and center spool. Assemble opposing side of spool. Install Adjusting Caps. (to 24 ft. lb. torque)  
 Test action and torque prior to use in field.

 **NOTICE:** Removal or improper replacement of adjusting screw (C) may affect torque setting. If torque setting is compromised wrench relief valve pressure must be reset and tested by a certified factory technician. Failure to observe this warning can result in tool failure and serious personal injury.

# REL-425C

## PARTS DRAWING

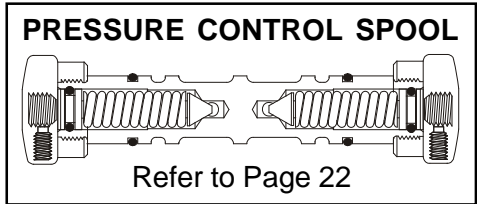
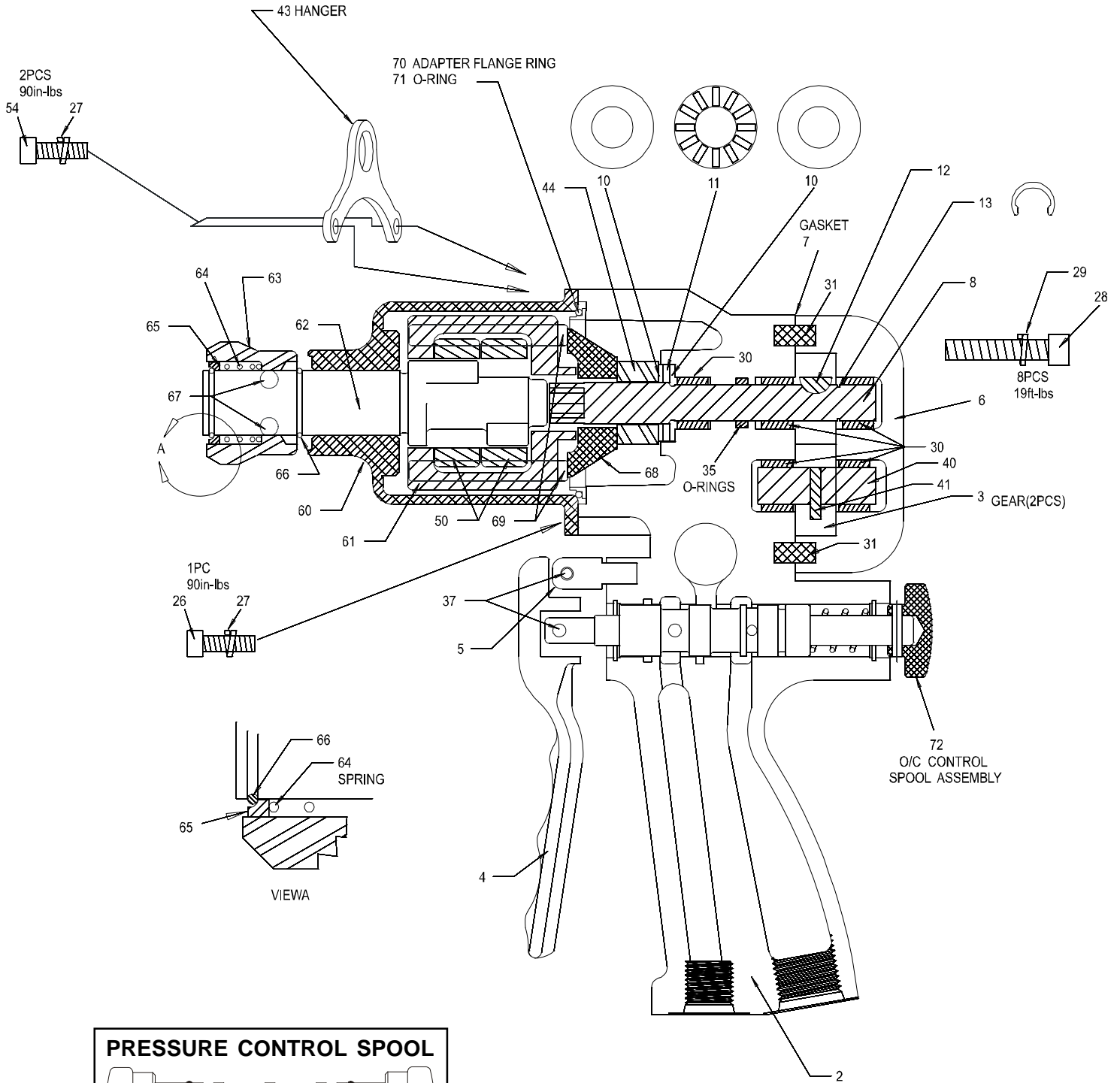

# REL-425C

## PARTS LIST - AFTER SERIAL #

Item #	Description	Part Number	# Req.
2	BODY**	46001K	1
NOTE: THIS PART IS NOT COMPATIBLE WITH PREVIOUS VERSIONS OF THE REL-425 IMPACT WRENCH			
3	GEAR	12875	2
4	TRIGGER	13104	1
5	NUT, TRIGGER	13105	1
6	MOTOR CAP**	13106	1
7*	GASKET, MOTOR-CAP, PURPLE PLASTIC	13107	1
8	DRIVESHAFT	13108	1
10	THRUST WASHER	13110	2
11	THRUST BEARING	13111	1
12	KEY, DRIVE	13112	1
13	CIRCLE CLIP, GEAR	13113	1
26	SCREW, FRONT END 5/8" LONG	13126	1
27	LOCKWASHER, FRONT END	13127	3
28	SOCKET HEAD SCREW, MOTOR-CAP	13128	8
29	LOCKWASHER, MOTOR-CAP	13129	8
30	NEEDLE BEARING	13130	5
31	DOWEL PIN	13131	2
35*	O-RING, DRIVE SHAFT	13135	1
37	COILED SPRING PIN	13137	2
40	IDLER SHAFT	13140	1
41	DRIVE PIN, IDLER	13141	1
42*	O-RING - INSIDE HANDLE BODY	46011	1
43	HANGER	13143	1
44	SPACER	13159	1
50	HAMMER	13150	2
54	SCREW, FRONT END, 3/4" LONG	13154	2
60	SHELL WITH BUSHING	13192	1
61	CAGE	13161	1
62	ANVIL	13172	1
63	CHUCK	13173	1
64	SPRING, ANVIL	13174	1
65	CAP, ANVIL SPRING	13177	1
66	RING CLIP	13178	1
67	DRIVE BALLS, 9/32"	13191	3
68	WASHER, PIN	13168	1
69	PINS, HAMMER	13169	2
70	ADAPTER FLANGE RING	13193	1
71*	O-RING FRONT END SEAL	13142	1
72	O/C SPOOL KIT (SEE PG 23 FOR PARTS)	46016	1
	HAND GUARD (OPTIONAL)	13158	1
	SCREW, HAND GUARD (REQ. W/ HAND GUARD)	13441	2
*	ITEMS IN SEAL KIT (SEE ALSO PG 22 AND PG 26)	46175	
**	SUPPLIED WITH BEARINGS PRESSED IN		

NOTE: THE REL-425C FEATURES AN UPDATED O/C SPOOL ASSEMBLY.

SEE PG #23 FOR PARTS AND ASSEMBLY DRAWING. SEE PAGE 16 FOR ASSEMBLY INSTRUCTIONS.

THE PRESSURE CONTROL SPOOL ASSEMBLY HAS NOT CHANGED FROM PREVIOUS MODEL REL-425B.

SEE PAGE 22 FOR CONTROL SPOOL ASSEMBLY DIAGRAM.

**REVISED REL-425C  
O/C SPOOL ASSEMBLY**  
BEGINNING WITH SERIAL # 9864

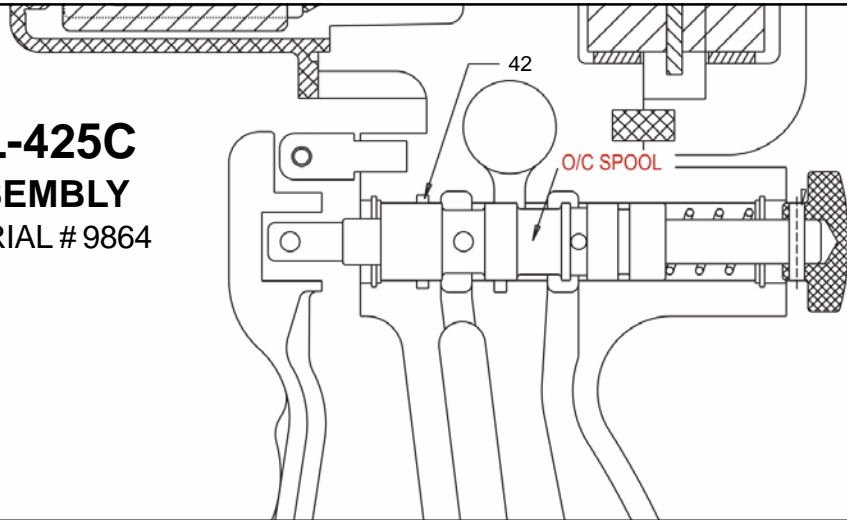

**REL-425C OPEN CENTER/CLOSED CENTER  
CONTROL SPOOL KIT PART # R46016**



Item #	Description	Part Number	# Req.
1	MAIN SPOOL	R46002	1
2*	O-RING, SPOOL	R46012	1
3*	O-RING, STEM	R46005	1
4	STEM	R46023	1
5	PINTLE	R46020	1
6	CLIP	R46006	1
7	SUPPORT WASHER	R46021	1
8*	SNAP RING	R46009	2
9	COILED SPRING PIN - TRIGGER (REFERENCED ON PG 20)	R13137	2
10	SPRING, MAIN SPOOL (REFERENCED ON PG 20)	R13109	1
11	O/C KNOB - REVISED 06/08	R46022	1
12	SET SCREW	R46024	2
13*	WASHER	R46010	1
42	O-RING - INSIDE HANDLE BODY	R46011	1

**NOTE: THE REL-425C FEATURES AN UPDATED O/C SPOOL ASSEMBLY.  
SEE PAGE 16 FOR ASSEMBLY INSTRUCTIONS.**

## REL-425TS

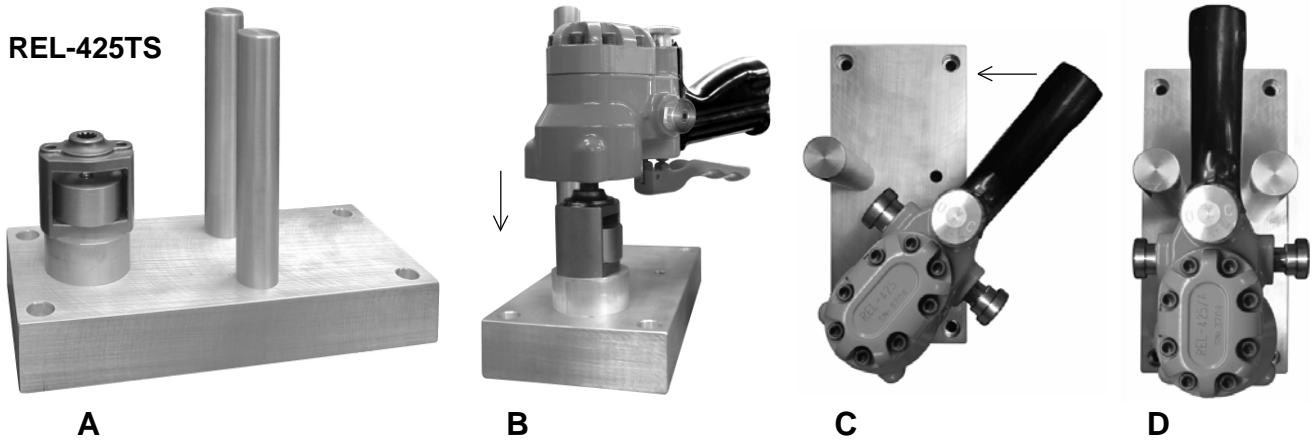

### WARNING

Wear proper eye protection.  
Do not lean over test assembly.  
Secure wrench into test stand before actuating trigger.  
Up to 80 inch-pounds of torque may be delivered!  
Failure to observe this warning may result in the wrench rotating at high speed causing tool damage and/or serious injury.

## SETTING RELIEF VALVE PRESSURE (USING REL-425TS TEST STAND)

### Checking Relief Valve Pressure

1. Position pressure control spool in forward direction.  
(The shaft rotates counter clockwise while looking at the hammer frame)
3. Place wrench into test stand **(A)**.  
Insert splined shaft of tool into test stand **(B)**.  
Rotate tool to center tool on test stand **(C)**.  
Insert removable safety post **(D)**.  
Connect test gauge into pressure port coupling, and Connect hoses from power source **(E)**.

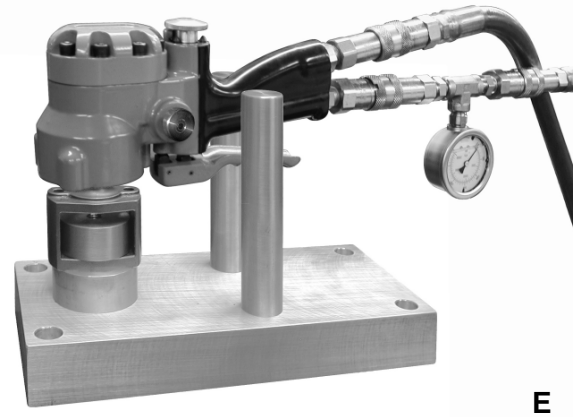

E

**NOTE:** Hydraulic power source should be set to 5 gpm at 2,000 psi

4. Hold handle securely and engage trigger on full ON position.
5. Read pressure on gauge. Pressure at gauge should be 1,300 psi  
**NOTE:** Reverse pressure at gauge should be 25 to 50 psi higher than forward setting.
6. If pressure is not in range, loosen small locking set screw (87).  
Turn large set screw (86) IN to raise pressure and OUT to lower pressure.
7. Turn large set screw (86) 1/4 turn at a time. Reset small locking set screw (87).
8. Repeat steps 4, 5, & 6, if necessary, until proper pressure setting is reached.
9. Position pressure control spool in reverse direction and repeat steps 1-8

### Final Assembly

1. Make sure locking set screws (87) are tight.
2. Recheck relief settings in both FORWARD and REVERSE positions.
3. Turn off power source. Depressurize hydraulic systems. Disconnect tool.
4. Reassemble impact housing as described on page 16.

