

OPERATORS' GUIDE

REL-58MC

MANUAL HYDRAULIC CUTTING TOOL

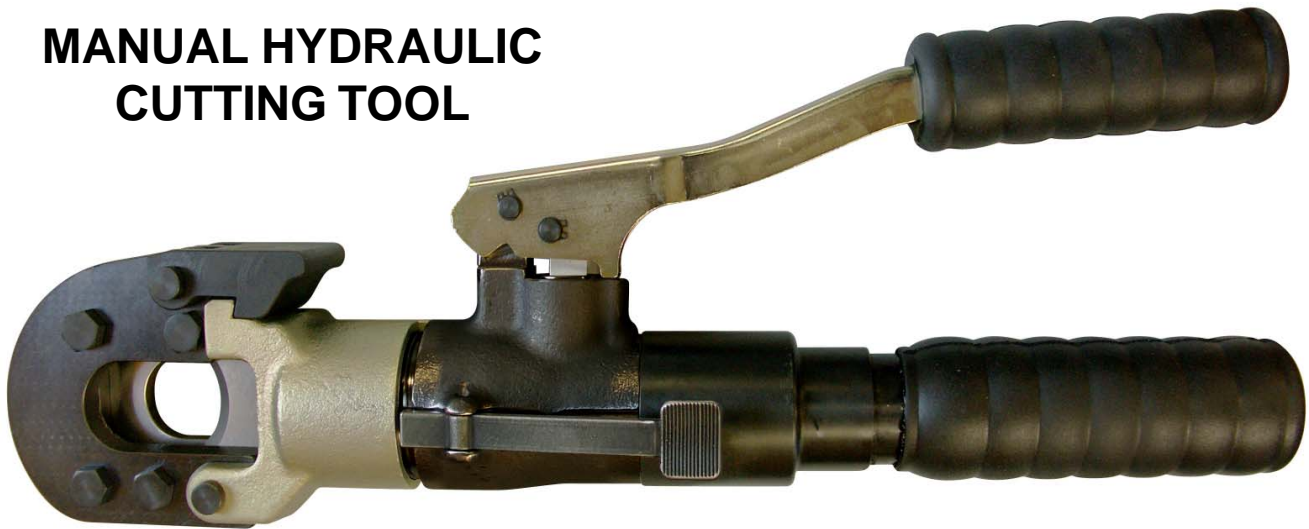

6 TONS OF CUTTING FORCE

WARNING



All information found in this guide must be read and understood before use or testing of this tool.

Failure to read and understand these warnings and safe handling instructions could result in severe personal injury and or death.

RELIABLE EQUIPMENT & SERVICE CO., INC.

92 Steamwhistle Drive • Ivyland, PA 18974 • USA

Phone: 215-357-3500 • Fax: 215-357-9193

MODEL: _____

MAX. PRESSURE: _____

SERIAL NO.: _____

YEAR: _____

NOTICE

Sizes, weights and tool specifications listed in this manual are subject to change without notice. Please consult factory for information and updates.



RELIABLE EQUIPMENT & SERVICE CO., INC.

REL-58MC Manual 07-06

DISTRIBUTED BY

REGISTRATION

UPON RECEIPT OF THIS TOOL, COMPLETE THE REGISTRATION BELOW.

COMPANY _____

ADDRESS _____

PHONE _____ FAX _____

SERIAL NUMBER _____

DATE OF PURCHASE _____

DEALER NAME _____



CAUTION

The information in this manual is intended to guide the user in the use and application of this tool. It is not intended as a substitute for proper training and experience in safe work practices for this type of equipment.

Consult your supervisor or safety personnel if you have any questions regarding the safe operation of this tool.

TABLE OF CONTENTS

DISTRIBUTOR INFORMATION.....	3
REGISTRATION	3
TABLE OF CONTENTS.....	4
TOOL SPECIFICATIONS	
REL-58MC - MANUAL HYDRAULIC.....	5
SAFETY INFORMATION AND WARNINGS.....	6-7
OPERATING INSTRUCTIONS	8
MAINTENANCE	9
GENERAL MAINTENANCE	9
PARTS DIAGRAM 1	10
PARTS DIAGRAM 2	11
PARTS DIAGRAM 3 (HEAD ASSEMBLY, EXPLODED VIEW)	12
PARTS DIAGRAM 4 (MULTIPLE COMPONENT ASSEMBLIES) ...	12
PARTS LIST	13
MAINTENANCE RECORDS	22
CONTACT INFORMATION	13

If you have any questions regarding the information found in this manual please contact RELIABLE EQUIPMENT at 800-966-3530 or FAX 215-357-9193.



THIS SYMBOL INDICATES ITEMS OF EXTREME IMPORTANCE.
Safety of user and others may be in jeopardy if these instructions are not read and understood.

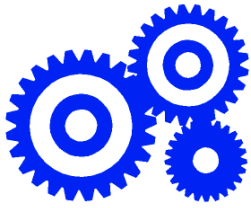

RELIABLE EQUIPMENT & SERVICE CO., INC.

REL-58MC MANUAL HYDRAULIC CUTTING TOOL

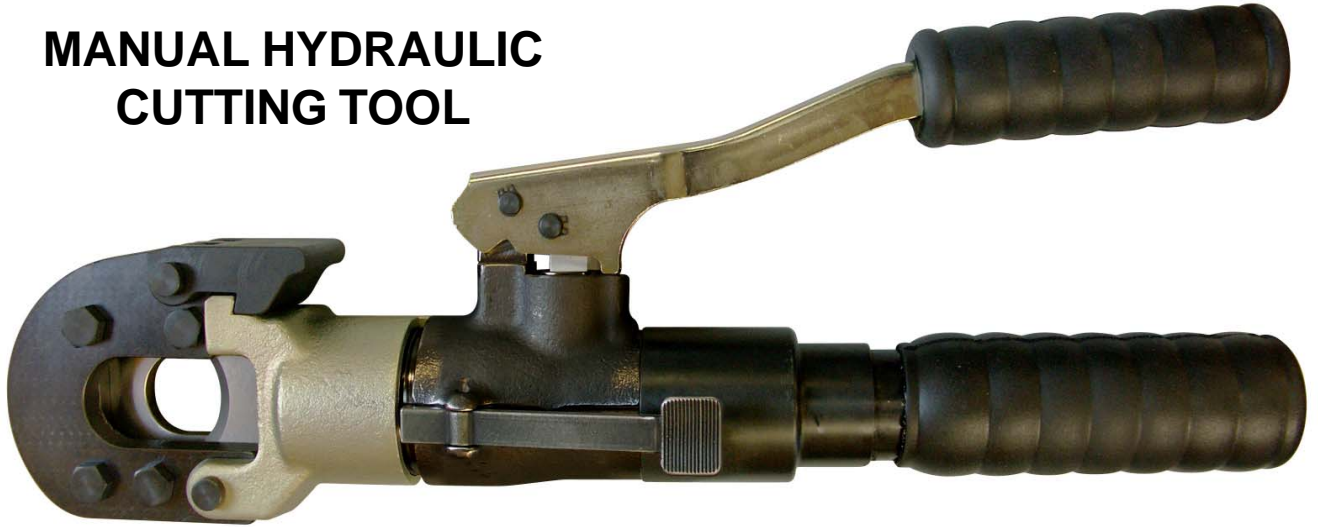

6 TONS OF CUTTING FORCE



REL-58MC

MANUAL HYDRAULIC CUTTER

Among the smallest hydraulic cutting tools available. Designed to cut copper, aldre, aluminum, aluminum-steel cables, EHS guy wire and steel ropes having a max overall diameter of 1" and steel ground rod up to 5/8". The tool features a double speed action. The blades are manufactured from high strength special steel, heat treated to ensure a long service life.

The head can rotate by 180 degrees, to enable the operator to work in the most comfortable position, and can easily be opened to allow the cutting of running cables. REL-58MC features an automatic safety valve to bypass oil when reaching maximum pressure; a pressure release device can also be operated at any stage of operation.

SPECIFICATIONS

Length	15.75 inches
Weight	7.7 lbs.
Pressure	10,000 psi (manual)
Capacity	1 in. Al., Guy Wire, Steel Rope
	5/8 in. Steel Ground Rod



RELIABLE EQUIPMENT & SERVICE CO., INC.

92 Steamwhistle Drive • Ivyland, PA 18974
Phone: 800-966-3530 • Fax: 215-357-9193
Visit us on the web at www.Reliable-Equip.com



WARNING

BEFORE USING THIS TOOL, READ THE WARNINGS and the recommended practices described in this manual. Failure by the operator to read and fully understand these warnings will leave this person unqualified to use and operate this tool. Property damage, severe personal injury, and/or death could result by not following these warnings.

These warnings will appear in appropriate locations when they are pertinent to the particular subject being shown. Read each one carefully and follow them strictly.



Eye Protection

WARNING

Always wear eye protection to avoid injury from flying debris or hydraulic oil leaks. Failure to do so can result in serious personal injury.



Skin Irritation

WARNING

Hydraulic oil may cause irritation. Use care to prevent contact with skin. In case of accidental contact, wash affected area immediately



Hard Hat

WARNING

Always wear a hard hat to avoid injury from falling debris. Failure to do so can result in serious personal injury.



Foot Protection

WARNING

Always wear foot protection. Failure to do so can result in serious personal injury.



Hearing Protection

WARNING

Always wear hearing protection, to avoid hearing loss due to long term exposure to high noise levels.



Protective Gloves

WARNING

Always wear protective gloves Failure to do so can result in serious personal injury.



CUTTING DANGER

This manual hydraulic cutting tool can cut and/or disable.
KEEP ALL PARTS OF THE BODY AWAY FROM MOVING PARTS.

WARNING

Failure to observe this warning could result in serious injury



ELECTRICAL SHOCK HAZARD

Always wear and use the necessary clothing, equipment and safety practices to protect against electrical shock. Failure to follow these rules can result in serious personal injury or death.

WARNING



GENERAL SAFETY



USE ALL APPROPRIATE AND APPLICABLE PERSONAL SAFETY EQUIPMENT as required by the operating company.

INSPECT TOOL BEFORE USE. Replace any worn, damaged or missing parts. A damaged or improperly assembled tool may injure operator and/or nearby personnel.

KEEP ALL PARTS OF THE BODY AWAY from moving parts of the tool.

KEEP HANDS OUT FROM BETWEEN CUTTING BLADES AT TOOL HEAD.

ALL BODY PARTS SHOULD BE OUTSIDE DANGER ZONE PRIOR TO CUTTING.

MAKE SURE there is no person in close proximity to you or the tool who could be injured by any operation being performed, tool malfunction or flying debris.

DO NOT OVEREXTEND your position by overreaching or unbalancing the footing necessary to maintain physical control of your body and the tool.

ALWAYS MAINTAIN a firm grip on the tool to avoid loss of control during an operation, causing property damage, serious injury or death.

USE THIS TOOL FOR THE MANUFACTURERS' INTENDED PURPOSE ONLY.

OBSERVE CLOSELY ALL OF THE SAFETY RULES FOR A PARTICULAR JOB CLASS

Operation/Safety methods may vary in accordance with the working guidelines established by each utility or contractor. Ensure that you fully comply with all safe operation guidelines required by your employer.

**FAILURE TO HEED THESE WARNINGS COULD RESULT IN
PROPERTY DAMAGE, SERIOUS PERSONAL INJURY OR DEATH.**

OPERATION

Read entire manual prior to using this tool. Refer to all safety cautions and warnings.

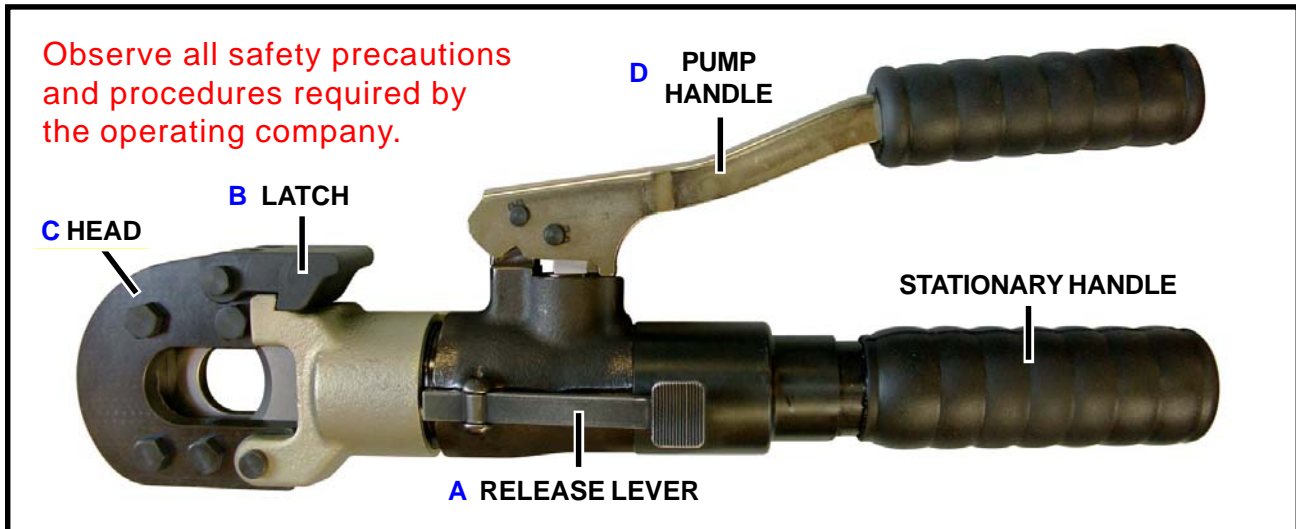

1. Before cutting, ensure that subject is within the capacity listed for the tool. (see page 4)
2. Retract blade completely by pressing hydraulic release lever (A).
3. Release latch (B), and open tool head for simple tool positioning around subject to be cut.
NOTE: Tool head rotates 180° to aid in proper alignment.
4. Place subject in tool head (C) and close latch securely.
NOTE: Failure to secure latch may result in severe tool damage and/or personal injury.
5. Position subject at a 90° angle to the tool head and cutting blade.
NOTE: Failure to cut subject at the proper 90° angle may result in severe tool damage and/or personal injury.



WARNING

Do not cut live conductors.

Hardened metals may fly when severed.

Take necessary precautions. wear safety glasses.

Keep all body parts away from cutting blades and moving parts.

Failure to follow these rules can result in serious personal injury or death.

6. Pump handle (D) to advance cutting blade up to subject. *Check tool alignment.*
7. Continue pumping handle until cut is complete.
8. Retract blade completely by pressing hydraulic release lever (A).

IF YOU HAVE ANY QUESTIONS REGARDING THE PROPER USE AND/OR OPERATION OF THIS TOOL, CONSULT YOUR AREA SUPERVISOR, OR CONTACT RELIABLE EQUIPMENT AT 800-966-3530

DAILY MAINTENANCE

The life, reliability, and safety of the tool is dependent on proper maintenance. Clean and inspect all surfaces including head, latch mechanism, blade, ram, body and handles.

WARNING blade, head and handles may cut or pinch. Please use extreme caution.

Worn or damaged parts (i.e. chipped or cracked blade) may malfunction during operation, causing more extensive damage to the tool and/or severe injury to the operator or bystander..

All parts must be replaced with new parts if signs of wear or damage are evident.

Keep Label Set clean and legible. Replace decals when necessary.



WARNING

Failure to observe all warnings and instructions could result in property damage, severe personal injury, and/or death.

BEFORE USING THIS PRODUCT READ THE SAFETY WARNINGS and recommended practices described in the manual. Failure by the operator to read and fully understand the warnings will leave this person unqualified to use and operate the tool.

Hardened metals may fly when severed. Take necessary precautions. wear safety glasses do not cut live conductors. Keep fingers away from cutting blades and moving parts.

Secure latch before operating. Failure to secure latch can result in severe tool damage and personal injury.



GENERAL MAINTENANCE

Complete disassembly is not recommended. Return the unit to an authorized dealer for total disassembly and/or repair.

All maintenance or disassembly should take place on a flat, clean work surface covered with towels or wipers so as to have a clean space for the disassembled parts.

Inspect each part during disassembly for wear, scratches, and cuts. Discard the worn or damaged parts and replace with new factory authorized parts. *See parts drawings on pg16-20.*

O-rings are sensitive to sharp edges. Inspect closely for cuts or damage. A small cut will cause a leak. When assembling or disassembling O-rings, use hydraulic fluid as a lubricant to help disassembly or installation.

When disposing of hydraulic parts or components observe all federal, state, and local guidelines.

IF YOU HAVE QUESTIONS REGARDING THE REPAIR AND MAINTENANCE OF THIS TOOL CONTACT RELIABLE EQUIPMENT AT 800-966-3530

REL-58MC PARTS DRAWING DIAGRAM 1

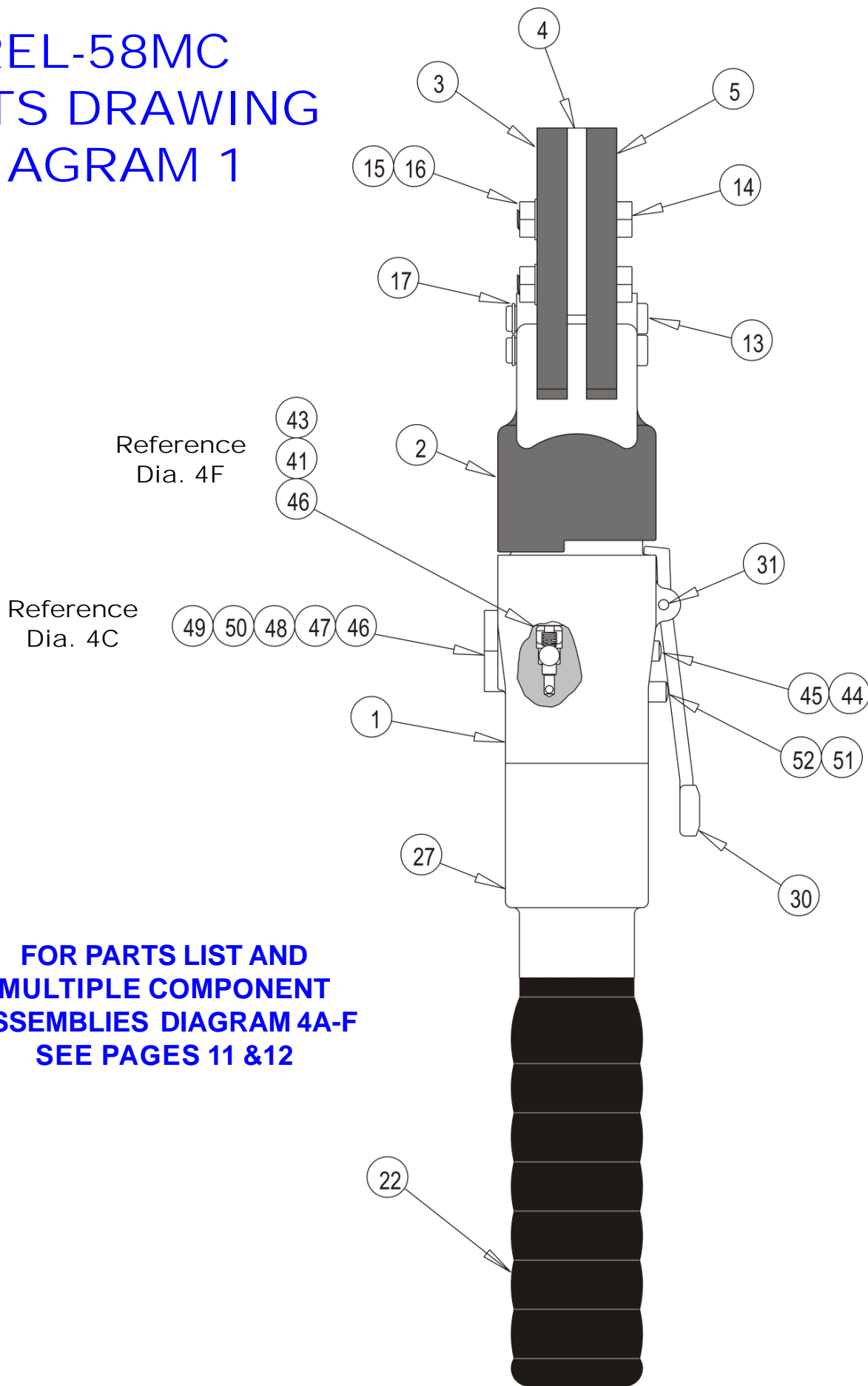

REL-58MC PARTS DRAWING DIAGRAM 2

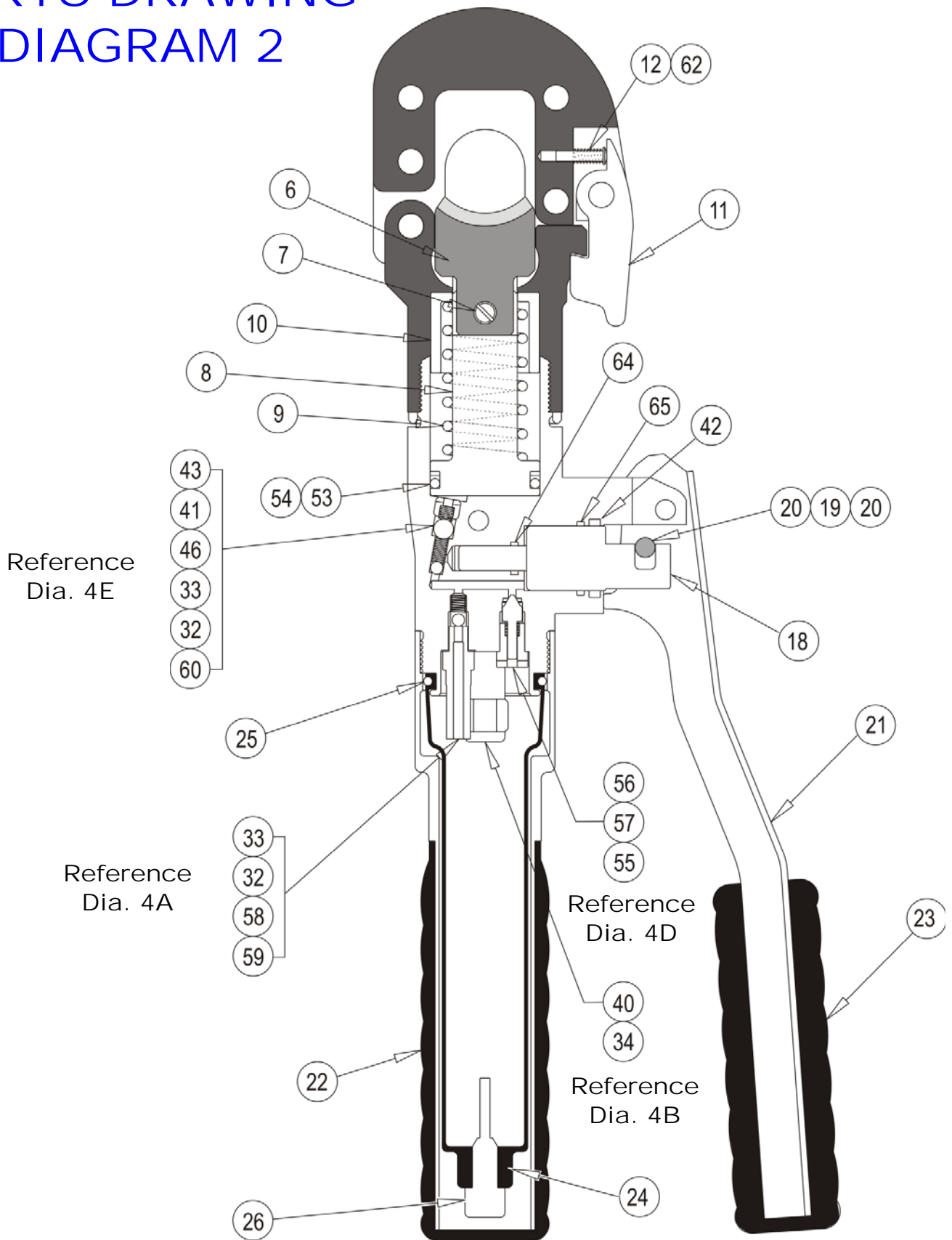

REL-58MC
EXPLODED HEAD
DIAGRAM 3

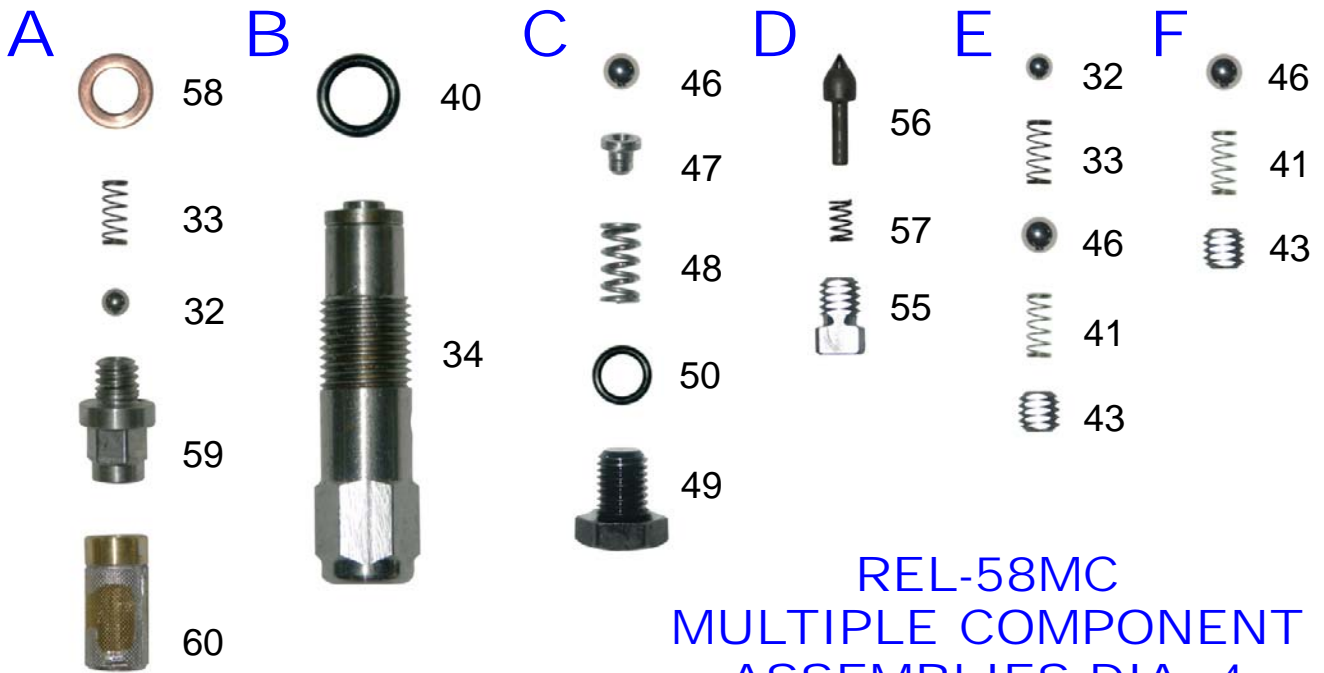
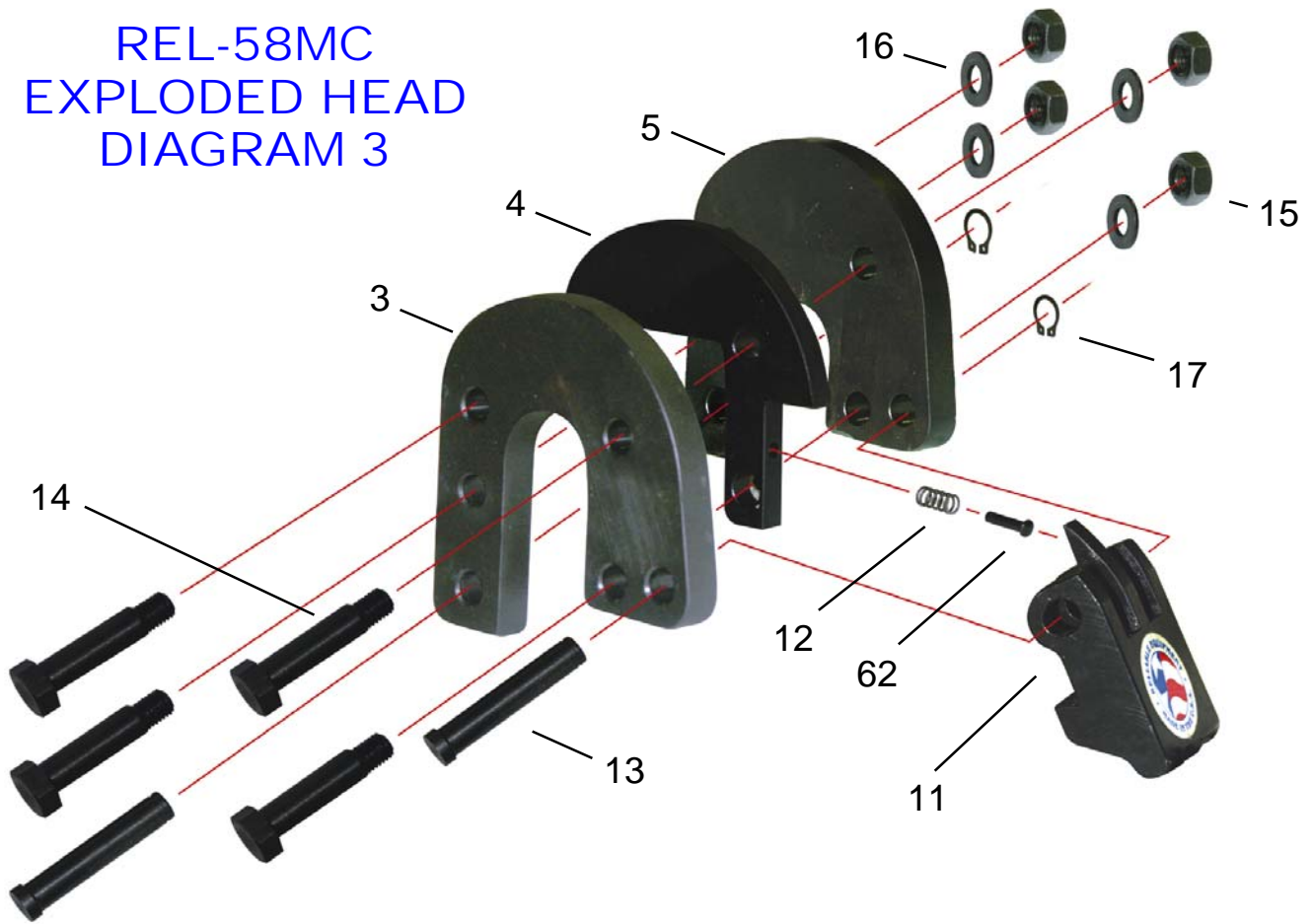

REL-58MC
MULTIPLE COMPONENT
ASSEMBLIES DIA. 4

ITEM	PART	QTY	DESCRIPTION
1	36001	1	BODY
2	36002	1	HEAD SUPPORT
3	36003	1	CUTTER HEAD
4	36004	1	SPACER, CUTTER HEAD
5	36005	1	SUPPORT, CUTTER HEAD
6	36006	1	CUTTER BLADE
7	36007	1	SCREW, BLADE HOLDER
8	36008	1	RAM
9	36009	1	SPRING, RAM
10	36010	1	GUIDE RING
11	36011	1	LATCH
12	24526	1	SPRING (LATCH)
13	36013	2	PIVOT PIN (HEAD ASSEMBLY)
14	36014	4	BOLT
15	36015	8	NUT
16	36016	8	WASHER
17	36017	2	C-CLIP (HEAD PIVOT PINS)
18	36018	1	INJECTOR
19	36019	2	PIN (MOVEABLE HANDLE)
20	36020	4	C-CLIP (MOVEABLE HANDLE)
21	36021	1	HANDLE, MOVEABLE
22	36022	1	LARGE GRIP
23	36023	1	SMALL GRIP
24	36024	1	OIL RESERVOIR
25	36025	1	O-RING (RESERVOIR)
26	36026	1	PLUG W/ MAGNET
27	36027	1	HANDLE
30	36030	1	LEVER
31	36031	1	COILED ROLL PIN (FOR LEVER)
32	36032	2	5/32 HARD BALL
33	36033	2	SPRING (FOR 5/32 HARD BALL)
34	36034	1	POP OFF VALVE
40	36040	1	O-RING, SEAT (POP-OFF VALVE)
41	36036	2	SPRING (FOR 7/32 DIA. BALL)
42	36037	1	WIPER (FOR PLUNGER)
43	36038	2	SCREW POSITIONING (FOR 7/32 DIA. BALL)
44	36039	1	PRESSURE RELEASE PIN
45	18208	1	O-RING (PRESSURE RELEASE PIN)
46	36041	3	7/32 DIA HARD BALL
47	36042	1	BALL SUPPORT (PRESSURE RELEASE ASSY)
48	36043	1	SPRING (GOES ON BALL SUPPORT)
49	36044	1	BOLT (PRESSURE RELEASE ASSY)
50	36045	1	O-RING (ASSEMBLE ON PRESSURE RELEASE BOLT)
51	36046	1	PIN LEVER SUPPORT
53	36047	1	SPRING (GOES WITH PIN LEVER SUPPORT)
54	36048	1	O-RING (GOES ON RAM)
55	36050	1	SCREW, FAST ADVANCE
56	36051	1	PINTLE, FAST ADVANCE
57	36052	1	SPRING, FAST ADVANCE
58	36053	1	COPPER WASHER
59	36054	1	INLET CHECK VALVE
60	36055	1	VENT
62	36057	1	SLIDE PIN (FOR LATCH)
63	36058	1	FINGER CLIP
64	36059	1	O-RING, SMALL (FOR PLUNGER)
65	36060	1	O-RING, LARGE (FOR PLUNGER)

