

OPERATORS' GUIDE

REL-58RH

SINGLE ACTING HYDRAULIC CUTTING TOOL



6 TONS OF CUTTING FORCE

RELIABLE EQUIPMENT & SERVICE CO., INC.

92 Steamwhistle Drive • Ivyland, PA 18974 • USA

Phone: 215-357-3500 • Fax: 215-357-9193

MODEL: _____

MAX. PRESSURE: _____

SERIAL NO.: _____

YEAR: _____

WARNING



All information found in this guide must be read and understood before use or testing of this tool.

Failure to read and understand these warnings and safe handling instructions could result in severe personal injury and or death.

NOTICE

Sizes, weights and tool specifications listed in this manual are subject to change without notice. Please consult factory for information and updates.

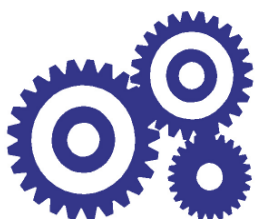

RELIABLE EQUIPMENT & SERVICE CO., INC.

REL-58MC Manual 03-07

DISTRIBUTED BY

REGISTRATION

UPON RECEIPT OF THIS TOOL, COMPLETE THE REGISTRATION BELOW.

COMPANY _____

ADDRESS _____

PHONE _____ FAX _____

SERIAL NUMBER _____

DATE OF PURCHASE _____

DEALER NAME _____



CAUTION

The information in this manual is intended to guide the user in the use and application of this tool. It is not intended as a substitute for proper training and experience in safe work practices for this type of equipment.

Consult your supervisor or safety personnel if you have any questions regarding the safe operation of this tool.

TABLE OF CONTENTS

DISTRIBUTOR INFORMATION.....	2
REGISTRATION	2
TABLE OF CONTENTS.....	3
TOOL SPECIFICATIONS	
REL-58RH - S/A REMOTE HYD. CUTTING TOOL	4
SAFETY INFORMATION AND WARNINGS.....	5-9
OPERATING INSTRUCTIONS	10
MAINTENANCE	11
GENERAL MAINTENANCE	11
PARTS DIAGRAM 1	12
PARTS DIAGRAM 2 (HEAD ASSEMBLY, EXPLODED VIEW)	12
PARTS LIST	13
MAINTENANCE RECORDS	14
CONTACT INFORMATION	14



If you have any questions regarding the information found in this manual please contact RELIABLE EQUIPMENT at 800-966-3530 or FAX 215-357-9193.



THIS SYMBOL INDICATES ITEMS OF EXTREME IMPORTANCE.
Safety of user and others may be in jeopardy if these instructions are not read and understood.

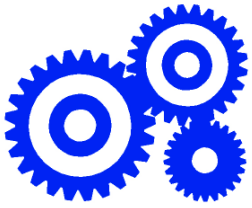

RELIABLE EQUIPMENT & SERVICE CO., INC.

REL-58RH

SINGLE ACTING HYDRAULIC CUTTING TOOL



6 TONS OF CUTTING FORCE



REL-58RH - SINGLE ACTING HYDRAULIC CUTTING TOOL

Among the smallest hydraulic cutting tools available. Designed to cut copper, aldre, aluminum, aluminum-steel cables, EHS guy wire and steel ropes having a max overall diameter of 1" and steel ground rod up to 5/8". The blades are manufactured from high strength special steel, heat treated to ensure a long service life.

The head will rotate by 180 degrees. Enabling the operator to work in the most comfortable position, reducing fatigue. The **REL-58RH** positive latch head opens easily to allow fast tool relocation, and simplify the cutting of running cables.

SPECIFICATIONS

Length	6.75 inch
Weight	4.0 lbs.
Pressure	10,000 psi
Wire Ropes	1 inch
Soft Steel Bolts	7/8 inch
Rebar, Ground & Anchor Rod	5/8 inch
Cu. & Al. Wire	1 inch
ACSR	1 inch
Stand. Guy Wire	7/8 inch
Lead Sheathed & Telephone Cable	DO NOT CUT



RELIABLE EQUIPMENT & SERVICE CO., INC.

92 Steamwhistle Drive • Ivyland, PA 18974
Phone: 800-966-3530 • Fax: 215-357-9193
Visit us on the web at www.Reliable-Equip.com



WARNING

BEFORE USING THIS TOOL, READ THE WARNINGS and the recommended practices described in this manual. Failure by the operator to read and fully understand these warnings will leave this person unqualified to use and operate this tool. Property damage, severe personal injury, and/or death could result by not following these warnings.

These warnings will appear in appropriate locations when they are pertinent to the particular subject being shown. Read each one carefully and follow them strictly.



Eye Protection

WARNING

Always wear eye protection to avoid injury from flying debris or hydraulic oil leaks. Failure to do so can result in serious personal injury.



Skin Irritation

WARNING

Hydraulic oil may cause irritation. Use care to prevent contact with skin. In case of accidental contact, wash affected area immediately



Hard Hat

WARNING

Always wear a hard hat to avoid injury from falling debris. Failure to do so can result in serious personal injury.



Foot Protection

WARNING

Always wear foot protection. Failure to do so can result in serious personal injury.



Hearing Protection

WARNING

Always wear hearing protection, to avoid hearing loss due to long term exposure to high noise levels.



Protective Gloves

WARNING

Always wear protective gloves Failure to do so can result in serious personal injury.



WARNING

SAFE OPERATION & CARE

USE THIS TOOL FOR ITS INTENDED PURPOSE ONLY

Any other use can result in personal injury or property damage.

INSPECT TOOL BEFORE USE. Replace any worn, damaged or missing parts. A damaged or improperly assembled tool may malfunction, injuring operator and/or nearby personnel.

INSPECT HYDRAULIC HOSES AND COUPLINGS before each use. Repair or replace if any cracking, leakage, wear or damage is found. Worn or damaged hoses may fail resulting in personal injury or property damage.

CLEAR WORK AREA of all bystanders and unnecessary personnel before operating this tool.

KEEP ALL PARTS OF THE BODY AWAY FROM MOVING PARTS.

Failure to observe this warning could result in serious injury.



WARNING

HYDRAULIC POWER SUPPLY

DO NOT attempt to make any changes to any of the component parts or accessories when connected to the power source.

DO NOT adjust, inspect, or clean tool while the tool is connected to the power source. The tool could accidentally start up and cause serious injury.

DO NOT lock the tool in the On Position. In an emergency, serious damage or injury could occur during the time required to stop the tool.



WARNING

TOOL HAZARD

DO NOT EXCEED THE MAXIMUM HYDRAULIC FLOW, RELIEF PRESSURE, OR BACK PRESSURE.

Failure to observe warnings could result in tool damage or injury.

IF YOU HAVE ANY QUESTIONS REGARDING THE SAFE USE AND/OR OPERATION OF THIS TOOL, CONSULT YOUR AREA SUPERVISOR, OR CONTACT RELIABLE EQUIPMENT AT 800-966-3530



WARNING

HOSES AND FITTINGS

There exists the potential for shock in using anything other than certified nonconductive hoses and hydraulic oil with dielectric properties, when using system components near energized electrical lines. Failure to recognize these conditions could cause electrocution.

Hoses and fittings used with this tool must comply with S.A.E. J1273 which covers recommended practice for selection, installation, and maintenance of hose and hose assemblies. The **correct hoses and fittings are available from your supplier.**

WARNING: Failure to comply with these warnings could result in severe bodily injury.



WARNING

UNIT/HOSE CONNECTIONS

ALWAYS DISCONNECT pump/power source and move toggle switch to **OFF** before connecting or disconnecting any components.

ALWAYS DEPRESSURIZE hydraulic system, before slowly disconnecting this unit or any of the systems components.

ALWAYS TIGHTEN couplings completely. Loose or improperly tightened couplings will not allow fluid to pass through the hose creating a blockage in the supply or return line.

ALWAYS INSPECT HOSES AND CONNECTORS before connection to tool. Replace or repair if any leakage is evident. Leakage is a sign of deterioration in component parts. Worn or leaking parts must be repaired or replaced, or tool damage or severe injury could result.



WARNING

OIL INJECTION INJURY

Hydraulic oil or fluid under the skin is a serious injury. Oil under pressure can penetrate the skin and may cause dismemberment or loss of life. Seek medical assistance immediately if such an injury should occur.

Always wear safety gloves, eye protection and all required safety equipment when operating or handling this tool.

DO NOT use fingers or hands to attempt to locate a leak.

DO NOT handle hoses or couplers while system is pressurized.

NEVER open or service the system before depressurizing.



WARNING

SERIOUS BURN HAZARD

HOT SURFACES MAY CAUSE SERIOUS BURN OR INJURY

The hydraulic cylinder may be hot during and after operation.

CAUTION: HYDRAULIC FLUID MAY CAUSE SERIOUS BURNS

Never disconnect tool, hoses, or fittings while the hydraulic power source is running or if the hydraulic fluid is hot.

Failure to observe this warning could result in serious injury.



WARNING

CUTTING DANGER

This hydraulic cutting tool can cut, dismember and/or disable.

KEEP ALL PARTS OF THE BODY AWAY FROM MOVING PARTS.

DO NOT lock the tool in the On Position. In an emergency, serious damage or injury could occur during the time required to stop the tool.

Failure to observe this warning could result in serious injury



WARNING

ELECTRICAL SHOCK HAZARD

Always wear and use the necessary clothing, equipment and safety practices to protect against electrical shock. Failure to follow these rules can result in serious personal injury or death.



WARNING

Operation/Safety methods may vary in accordance with the working guidelines established by each utility or contractor.

For your own safety, ensure that you fully comply with all safe operation guidelines required by your employer.

IF YOU HAVE ANY QUESTIONS REGARDING THE SAFE USE AND/OR OPERATION OF THIS TOOL, CONSULT YOUR AREA SUPERVISOR, OR CONTACT RELIABLE EQUIPMENT AT 800-966-3530



GENERAL SAFETY



USE ALL APPROPRIATE AND APPLICABLE PERSONAL SAFETY EQUIPMENT as required by the operating company.

INSPECT TOOL BEFORE USE. Replace any worn, damaged or missing parts. A damaged or improperly assembled tool may injure operator and/or nearby personnel.

KEEP ALL PARTS OF THE BODY AWAY from moving parts of the tool.

KEEP HANDS OUT FROM BETWEEN CUTTING BLADES AT TOOL HEAD.

ALL BODY PARTS SHOULD BE OUTSIDE DANGER ZONE PRIOR TO CUTTING.

MAKE SURE there is no person in close proximity to you or the tool who could be injured by any operation being performed, tool malfunction or flying debris.

DO NOT OVEREXTEND your position by overreaching or unbalancing the footing necessary to maintain physical control of your body and the tool.

ALWAYS MAINTAIN a firm grip on the tool to avoid loss of control during an operation, causing property damage, serious injury or death.

USE THIS TOOL FOR THE MANUFACTURERS' INTENDED PURPOSE ONLY.

OBSERVE CLOSELY ALL OF THE SAFETY RULES FOR A PARTICULAR JOB CLASS

Operation/Safety methods may vary in accordance with the working guidelines established by each utility or contractor. Ensure that you fully comply with all safe operation guidelines required by your employer.

**FAILURE TO HEED THESE WARNINGS COULD RESULT IN
PROPERTY DAMAGE, SERIOUS PERSONAL INJURY OR DEATH.**

OPERATION

Read entire manual prior to using this tool. Refer to all safety cautions and warnings. Observe all safety precautions and procedures required by the operating company. (Also refer to SAFETY information found on pages 6 through 10)

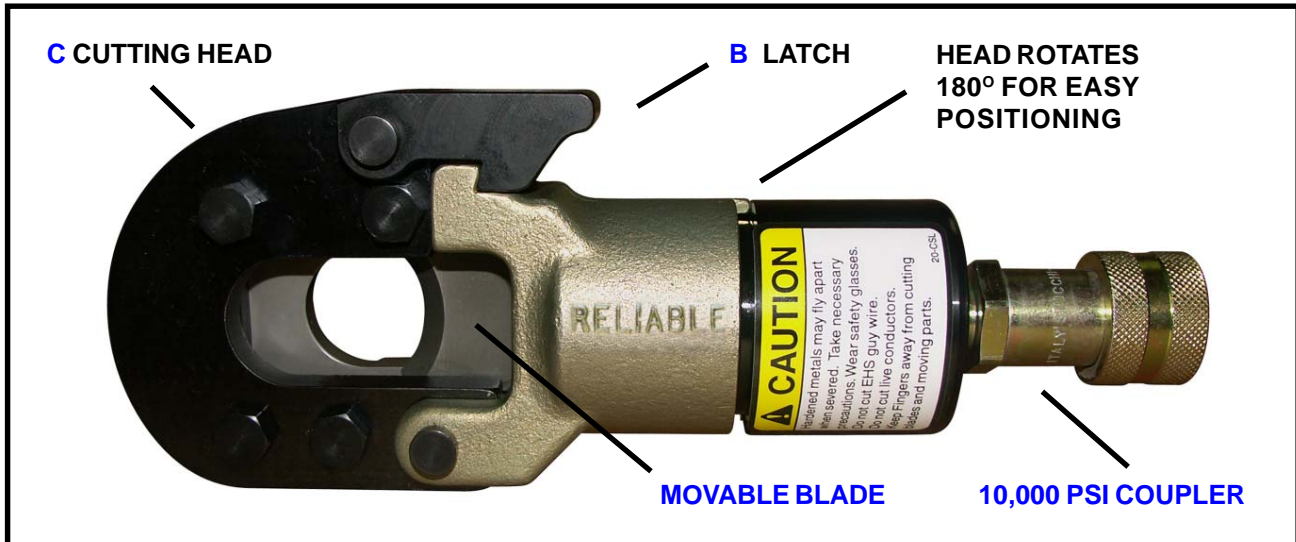

WARNING

Do not cut live conductors.

Hardened metals may fly when severed.

Take necessary precautions. wear safety glasses.

Keep all body parts away from cutting blades and moving parts.

Failure to follow these rules can result in serious personal injury or death.

1. Before cutting, ensure that subject is within the capacity listed for the tool. (see page 5)
2. Connect to a 10,000 psi power source with an audible “Pop Off” type relief valve. (Recommended for best operation) (Refer to page 8 UNIT/HOSE CONNECTION)
2. Ensure movable blade has retracted completely.
3. Release latch (B), and open tool head for simple tool positioning around subject to be cut.
NOTE: Tool head rotates 180° to aid in proper alignment.
4. Place subject in tool head (C) and close latch securely.
WARNING: Failure to secure latch may result in severe tool damage and/or personal injury.
5. Position subject at a 90° angle to the tool head and cutting blade.
NOTE: Failure to cut subject at the proper 90° angle may result in severe tool damage and/or personal injury.
7. Turn power source “ON” and activate control valve to advance movable blade up to subject. **Check tool alignment.**
8. Continue to advance until cut is complete.
9. Return source to the “OFF” position and allow movable blade to retract completely.

DAILY MAINTENANCE

The life, reliability, and safety of the tool is dependent on proper maintenance. Clean and inspect all surfaces including head, latch mechanism, blade, ram, and body.

WARNING blade, head may cut or pinch. Please use extreme caution.

Worn or damaged parts (i.e. chipped or cracked blade) may malfunction during operation, causing more extensive damage to the tool and/or severe injury to the operator or bystander..

All parts must be replaced with new parts if signs of wear or damage are evident.

Keep Label Set clean and legible. Replace decals when necessary.



WARNING

BEFORE USING THIS PRODUCT READ THE SAFETY WARNINGS and recommended practices described in the manual. Failure by the operator to read and fully understand the warnings will leave this person unqualified to use and operate the tool.

Failure to observe all warnings and instructions could result in property damage, severe personal injury, and/or death.

Hardened metals may fly when severed. Take necessary precautions. wear safety glasses do not cut live conductors. Keep fingers away from cutting blades and moving parts.

Secure latch before operating. Failure to secure latch can result in severe tool damage and personal injury.

CAUTION

Operation and safety methods may vary in accordance with the guidelines established by each utility. For your safety, ensure that you fully comply with all safe operation guidelines established by your respective power utility.

REL-SM

DANGER

 The user should be properly trained in the correct procedures required for work on or around electrical lines.

GENERAL MAINTENANCE

Complete disassembly is not recommended. Return the unit to an authorized dealer for total disassembly and/or repair.

All maintenance or disassembly should take place on a flat, clean work surface covered with towels or wipers so as to have a clean space for the disassembled parts.

Inspect each part during disassembly for wear, scratches, and cuts. Discard the worn or damaged parts and replace with new factory authorized parts. *See parts drawings on pg16-20.*

O-rings are sensitive to sharp edges. Inspect closely for cuts or damage. A small cut will cause a leak. When assembling or disassembling O-rings, use hydraulic fluid as a lubricant to help disassembly or installation.

When disposing of hydraulic parts or components observe all federal, state, and local guidelines.

IF YOU HAVE QUESTIONS REGARDING THE REPAIR AND MAINTENANCE OF THIS TOOL CONTACT RELIABLE EQUIPMENT AT 800-966-3530

REL-58RH SINGLE ACTING HYDRAULIC CUTTING TOOL

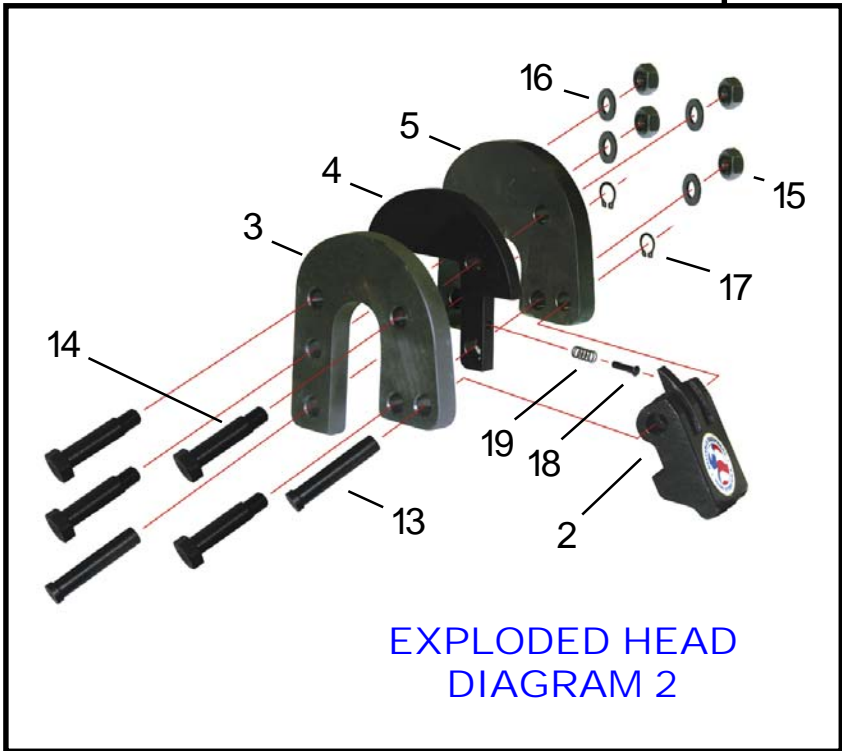
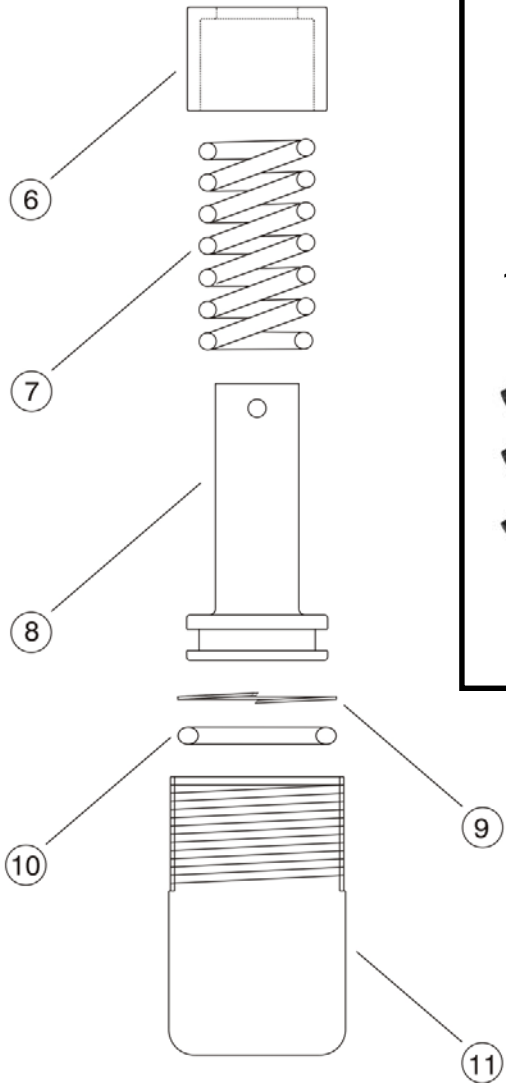
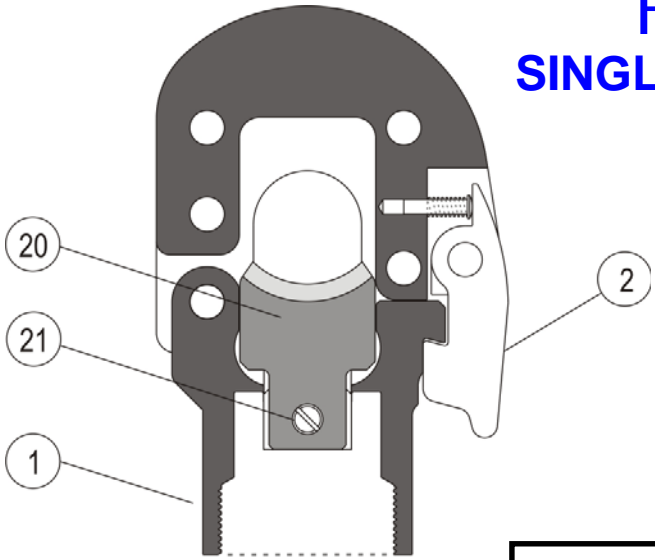

EXPLODED HEAD
DIAGRAM 2

DIAGRAM 1

REL-58RH - PARTS LIST

ITEM	PART	QTY	DESCRIPTION
1	R36002	1	HEAD SUPPORT
2	R36011	1	LATCH
3	R36003	1	CUTTER HEAD
4	R36004	1	SPACER, CUTTER HEAD
5	R36005	1	SUPPORT, CUTTER HEAD
6	R36010	1	GUIDE RING
7	R36009	1	SPRING
8	R43102	1	RAM
9	R41012	1	BACK-UP RING
10	R41013	1	O-RING
11	R43501	1	CYLINDER
12	-----	--	-----
13	R36013	2	PIVOT PIN (HEAD ASSEMBLY)
14	R36014	4	BOLT
15	R36015	8	NUT
16	R36016	8	WASHER
17	R36017	2	C-CLIP (HEAD PIVOT PINS)
18	R36057	1	SLIDE PIN (FOR LATCH)
19	R24526	1	SPRING (LATCH)
20	R36006	1	CUTTER BLADE
21	R36007	1	SCREW, BLADE HOLDER

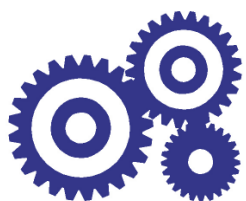

**RELIABLE EQUIPMENT
& SERVICE CO., INC.**

