

OPERATORS' GUIDE

REL-GRD-1 "THE DOOGIE DRIVER" GROUND ROD DRIVER

The **NEW** REL-GRD-1 Ground Rod Driver from **RELIABLE EQUIPMENT** has been designed to drive 1/2 - 5/8 inch galvanized ground rods **FAST**.

Optional: A 3/4-1 inch model is also available.

WARNING



All information found in this guide must be read and understood before use or testing of this tool.

Failure to read and understand these warnings and safe handling instructions could result in severe personal injury and or death.

NOTICE

Sizes, weights and tool specifications listed in this manual are subject to change without notice. Please consult factory for information and updates.

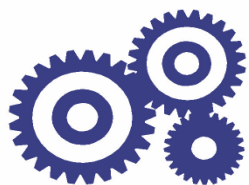

RELIABLE EQUIPMENT & SERVICE CO., INC.

REL-GRD-1 Manual 04-09

TABLE OF CONTENTS

Registration	2	PARTS DIAGRAMS AND LISTS	
Description	3	REL-GRD-1	12-14
General Safety	4-6	Parts List - REL-GRD-1	15
SPECIFICATIONS		Parts List - R27600 Valve	16
General	7	Accumulator - Charge & Test	16
Connections and Hoses	8	Trouble Shooting.....	17
Pre-Operation	9	Disassembly	18
ON/OFF Valve for O/C or C/C	9	Assembly Photo	19
Ground Rod Driver Operation ...	10	Maintenance Record	20
Disconnect Hoses	10	Contact Information	20
MAINTENANCE			
General	11		
Safety Labels	11		
Hydraulic Fluid	11		

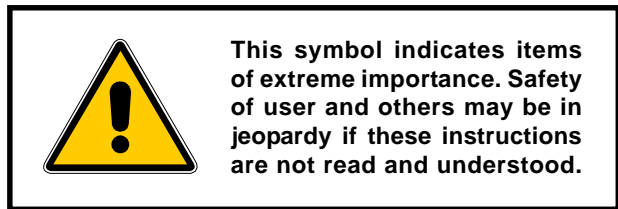

REGISTRATION

UPON RECEIPT OF THIS TOOL, COMPLETE THE REGISTRATION BELOW.

COMPANY _____

ADDRESS _____

PHONE _____ FAX _____

SERIAL NUMBER _____

DATE OF PURCHASE _____

DEALER NAME _____

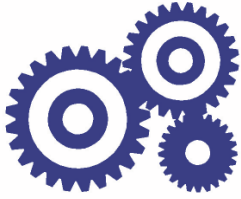

RELIABLE EQUIPMENT & SERVICE CO., INC.



REL-GRD-1 "THE DOOGIE DRIVER" GROUND ROD DRIVER

Available March 1st, 2009

The **NEW** REL-GRD-1 Ground Rod Driver from **RELIABLE EQUIPMENT** has been designed to drive 1/2 - 5/8 inch galvanized ground rods **FAST**.

A 3/4-1 inch model is also available.

Cushioned "Comfort Grip" handles run the length of the tool body providing two handed control while reducing operator fatigue.

70 inch whips with remote in-line ON/OFF valve provides convenient access to control for accurate drive depth.

Operate from any Open- or Closed- Center hydraulic systems.

The integral lifting eye allows the driver to be lifted and suspended above the rod reducing operator strain.

Flush face quick disconnect couplers are factory installed, so you may use the tool right out of the box.

SPECIFICATIONS

Pressure	2000 psi Max.
Flow	5-8 gpm (18-30 lpm)
Whip Set	70 inches (178 cm)
Ports	9/16 - 18 SAE O-Ring
Weight	44 lbs. (24.0 kg)
Length	25 1/2 inches (654 mm)



**RELIABLE
EQUIPMENT**
CRAFTED WITH PRIDE IN THE U.S.A.

92 Steamwhistle Drive • Ivyland, PA 18974
Phone: 800-966-3530 • Fax: 215-357-9193
Visit us on the web at www.Reliable-Equip.com



WARNING

BEFORE USING THIS TOOL, READ THE WARNINGS and the recommended practices described in this manual. Failure by the operator to read and fully understand these warnings will leave this person unqualified to use and operate this tool. Property damage, severe personal injury, and/or death could result by not following these warnings.

These warnings will appear in appropriate locations when they are pertinent to the particular subject being shown. Read each one carefully and follow them strictly.



Eye Protection

WARNING

Always wear eye protection to avoid injury from flying debris or hydraulic oil leaks. Failure to do so can result in serious personal injury.



Dust Mask

WARNING

Always wear a dust mask. Failure to observe this warning may result in serious health issues and/or breathing difficulty.



Hard Hat

WARNING

Always wear a hard hat to avoid injury from falling debris. Failure to do so can result in serious personal injury.



Foot Protection

WARNING

Always wear foot protection. Failure to do so can result in serious personal injury.



Hearing Protection

WARNING

Always wear hearing protection, to avoid hearing loss due to long term exposure to high noise levels.



Protective Gloves

WARNING

Always wear protective gloves. Failure to do so can result in serious personal injury.



WARNING

Safe Operation & Care

USE THIS TOOL FOR ITS INTENDED PURPOSE ONLY
Any other use can result in injury or property damage.
INSPECT TOOL BEFORE USE. Replace any worn, damaged or missing parts. A damaged or improperly assembled tool may malfunction, injuring operator and/or nearby personnel.
INSPECT HYDRAULIC HOSES AND COUPLINGS before each use. Repair or replace if any cracking, leakage, wear or damage is found. Worn or damaged hoses may fail resulting in personal injury or property damage.
CLEAR WORK AREA of all bystanders and unnecessary personnel before operating this tool.
KEEP ALL PARTS OF THE BODY AWAY FROM MOVING PARTS.
Failure to observe this warning could result in serious injury.



WARNING

Safety

DO NOT attempt to make any changes to any of the component parts or accessories when connected to the power source.
DO NOT adjust, inspect, or clean tool while the tool is connected to the power source. The tool could accidentally start up and cause serious injury.
DO NOT lock the tool in the On Position. In an emergency, serious damage or injury could occur during the time required to stop the tool.



WARNING

Oil Injection Injury

Hydraulic oil or fluid under the skin is a serious injury. Oil under pressure can penetrate the skin and may cause dismemberment or loss of life. Seek medical assistance immediately if such an injury should occur.
Always wear safety gloves, eye protection and all required safety equipment when operating or handling this tool.
DO NOT use fingers or hands to attempt to locate a leak.
DO NOT handle hoses or couplers while system is pressurized.
NEVER open or service the system before depressurizing.



WARNING

Burn Hazard

Do Not connect or disconnect tool, hoses or fittings while power source is running or while hydraulic fluid is hot. Hot hydraulic fluid may cause serious burns.

Failure to observe this warning could result in serious injury.



WARNING

Electrical Shock Hazard

Use only certified nonconductive hoses and fittings. Always wear and use the necessary clothing, equipment and safety practices to protect against electrical shock. Failure to follow these rules can result in serious personal injury or death.



CAUTION

Vibration Hazard

Apply just enough pressure to control the tool operation. Applying excess pressure to the tool may cause operator discomfort or temporary numbness.

Failure to observe this warning could result in serious injury.



CAUTION

Safe Handling

HYDRAULIC FLUID MAY CAUSE SKIN IRRITATION.

Prevent hydraulic fluid from making contact with skin.

IN THE EVENT OF SKIN CONTACT immediately wash thoroughly.

Failure to observe this warning could result in injury.



CAUTION

General Safety

Ensure that all fellow employees and bystanders are clear and protected from possible injury caused by this tool or the operations being performed. Persons in close proximity could be injured and property damaged if the tool were to malfunction.

This tool should always be used within the limits and purposes stated by the product manufacturer. Abuse or usage beyond the manufacturers' intended purposes could cause damage to the tool and severe injury to the operator.

TOOL SPECIFICATIONS

Overall Length (W/O HOSES) 25 1/2 in.
Handle Width 8.0 in.
Weight..... 44 lbs.

HYDRAULIC POWER SOURCE SPECIFICATIONS

The following requirements are essential for the safe operation of this tool.

Hydraulic System **Open- or Closed- Center**
Flow Range..... 6 gpm Minimum
..... 7 gpm Optimum
..... 8 gpm Maximum
Operating Pressure 1,800 - 2,200 psi
Filtration 10 Micron Nominal
Back Pressure 200 psi Maximum *
Pressure Port Thread..... 3/4-16 Female SAE O-Ring
Return Port Thread 3/4-16 Female SAE O-Ring

* 200 psi (1,379 kPa) is the maximum agreed standard for the HTMA (Hydraulic Tool Manufacturers Association).

If you have any questions regarding the information in this manual contact **RELIABLE EQUIPMENT** at the address, phone or fax numbers on page 3.



WARNING

These specifications must be strictly adhered to for the safe and effective operation of this tool.

HYDRAULIC FLOW MUST NOT EXCEED 8 GPM

LIMIT RELIEF SETTINGS TO 2,000 PSI (13,790 kPa)

Any deviation can result in severe injury or death to the operator and or extraneous personnel.



WARNING

HOSES AND FITTINGS

There exists the potential for shock in using anything other than certified nonconductive hoses and hydraulic oil with dielectric properties, when using system components near energized electrical lines. Failure to recognize these conditions could cause electrocution.

Hoses and fittings used with this tool must comply with S.A.E. J1273 which covers recommended practice for selection, installation, and maintenance of hose and hose assemblies. The **correct hoses and fittings are available from your supplier.**

WARNING: Failure to comply with these warnings could result in severe bodily injury.



WARNING

UNIT/HOSE CONNECTIONS

ALWAYS SHUT OFF pump/power source and move flow selector to **OFF** before connecting or disconnecting system components.

ALWAYS DEPRESSURIZE hydraulic system before slowly disconnecting this unit or any of the systems components.

ALWAYS TIGHTEN couplings completely. Loose or improperly tightened couplings will not allow fluid to pass through the hose creating a blockage in the supply or return line.

ALWAYS INSPECT HOSES AND CONNECTORS before connection to tool. Replace or repair if any leakage is evident. Leakage is a sign of deterioration in component parts. Worn or leaking parts must be repaired or replaced, or tool damage or severe injury could result.



CAUTION

HOSE INSTALLATION

Care must be taken to assure the correct connection of the hoses to the pressure “P” and return “T” ports.

Connect the return hose to the return port on the power source, then to the return “T” port on the tool.

Connect the pressure hose to the pressure port “P” on the tool, then to the pressure port on the power source.

Operation with hydraulic flow reversed can cause malfunction. Failure to fully comply can result in tool damage, injury, or death.

PRE-OPERATION OF TOOL



WARNING

DO NOT connect hoses or fittings to this unit before completing all of the instructions in this section.

Ensure power source is **OFF**, and hydraulic flow is lever is turned **OFF**.

Failure to comply with this warning can result in severe injury or death.

Before attempting to run or use the tool, check all connections, including hoses, and couplings. Ensure that valve is moving freely.

Wear all safety items required and make sure that the working area is clear of obstructions and non essential personnel.

Set the Valve to Open- or Closed-Center, according to which system the power supply pump provides. It is important to know which type of power system is supplying the tool so that the REL-GRD-1 can be properly set.

All these items are crucial to the safe operating procedure of the REL-GRD-1.

Tool Set-up for Open-Center or Closed-Center Systems

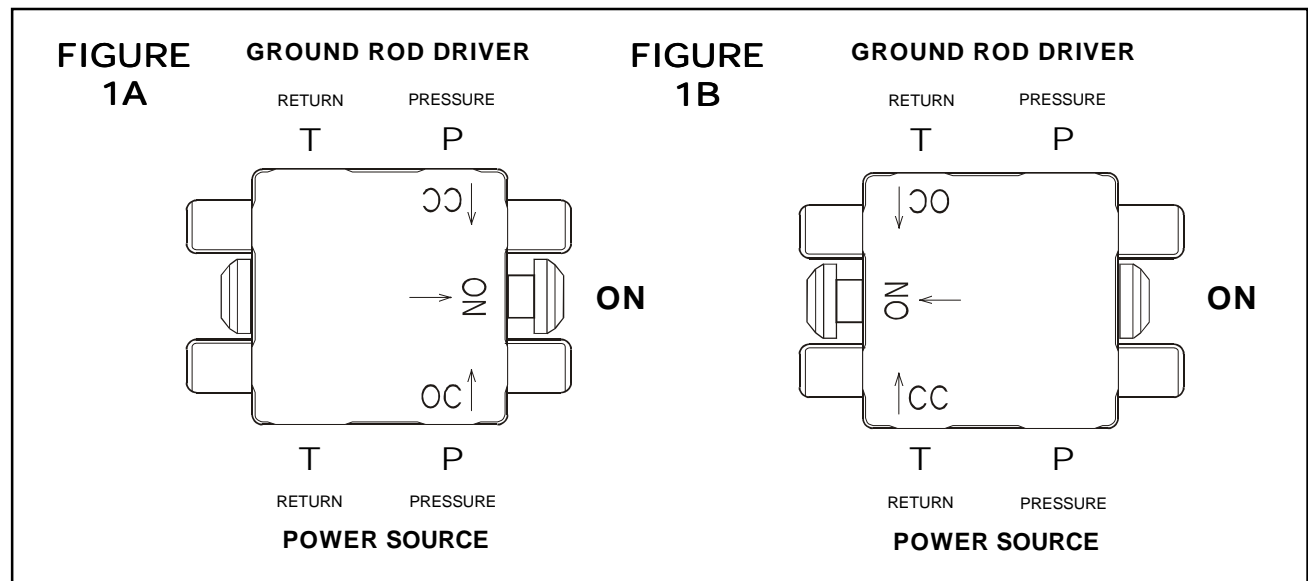

Model REL-GRD-1 (Refer to the illustration in **Figure 1A** above.)

This model is factory configured for Open-Center operation. (as shown above) Connect pressure and return from power source to OC ports on valve as shown above.

Valve Conversion for Closed-Center Operation: (Refer to **Figure 1B** above)

Rotate valve 180°. Connect return & pressure hoses from REL-GRD-1 to OC ports on valve. Connect return and pressure from power source to the CC ports on valve as shown above.

GROUND ROD DRIVER OPERATION

There are a number of safety items that need to be addressed when using the tool. Seek out the supervisor for basic instruction in handling the tool. Some basic problems are easily overcome by knowing the rules of operation.

Make sure that the correct anvil for the rod size being driven is inserted. (5/8" from Factory)

Inspect, set-up and connect the tool as described on the previous pages.

Start the hydraulic power source.

Allow the power source to run for a few minutes to warm the hydraulic fluid.

Slide the ground rod into the driver.

Raise the rod and driver to a vertical position and ensure adequate down pressure is applied.

NOTE: Due to the weight and raised position of the rod and the driver, it is recommended that the lifting procedure be performed by two persons for lift and transport.

Activate control valve or control spool to the **ON** position. (Refer to Figure 1A or 1B)

Firmly grasp the tube with both hands. Ensure proper footing and balance.

Apply light downward pressure to the REL-GRD-1.



WARNING: Driver operation does not require excessive pressure. Excess pressure may cause operator discomfort, fatigue or numbness.

Operator must maintain a firm grip and proper balance, controlling the tool with both hands at all times. Failure to maintain control of the tool could result in severe personal injury or death.

When finishing with the operation, move the control spool to the **OFF** position.

Move the flow lever on the power source to the **OFF** position.

Stop the hydraulic power source.



WARNING: DO NOT disconnect the tool, hoses, or fittings while the tool is running, hot, or under pressure. Serious injury or burns could result.

DISCONNECT HOSES

Move the flow lever on the power source to the **OFF** position.

Stop the hydraulic power source.

Disconnect the pressure hose from the pressure "P" port on the power source, then disconnect the hose from the pressure port on the tool.

Disconnect the return hose from the return "T" port on the tool, then disconnect the hose from the return port on the power source.

Install dust caps on all connectors to prevent dirt and contaminants from entering the hydraulic system.

MAINTENANCE

The life, reliability, and safety of the tool is dependent on proper maintenance.

DAILY MAINTENANCE

Clean all surfaces including handle, trigger, valve, fittings, hoses and housing.

Inspect tool for wear and damage.

Worn or damaged parts can cause malfunction during operation.

Inspect for cracked hoses and leaking fittings.

Check fluid level of the power source reservoir frequently.

All the above items must be replaced with new parts if signs of wear are evident.

FLUID CONTAMINATION: Cover the ends of fittings with a dust cap when disconnected. This will help keep the fluid from contamination.

MONTHLY MAINTENANCE: Inspect per Appendix A, SAE Standard J1273, 5/86 for hose or fitting damage such as wear, cracks or leakage, replace the necessary parts.

NOTE: Keep Label Set clean and legible. Replace decals when necessary. Part #RL27400



WARNING

BEFORE USING THIS PRODUCT READ THE SAFETY WARNINGS and recommended practices described in the manual. Failure by the operator to read and fully understand the warnings will leave this person unqualified to use and operate the tool.

Failure to observe all warnings and instructions could result in property damage, severe personal injury, and/or death.



WARNING

This tool is factory configured for Open-Center Tool Systems. Convert for Closed-Center Use

Rotate the valve 180°. Connect from tamper to OC ports on valve. Failure to observe all warnings could result in property damage, severe injury, and/or death. Connect return and pressure from power source to the CC ports on valve.



CAUTION

Operation and safety methods may vary in accordance with the guidelines established by each utility. For your safety, ensure that you fully comply with all safe operation guidelines established by your respective power utility.

REL-SM



DANGER

The user should be properly trained in the correct procedures required for work on or around electrical lines.

HYDRAULIC FLUIDS

All hydraulic fluids that meet these listed specifications or the listed HTMA specifications may be used for this tool.

S. U. S.

@ 100° F (38° C) 140 TO 225

@ 210° F (99° C) 40 minimum

FLASH POINT 340° F min. (170° C min.)

POUR POINT -30° F min. (-34° C min.)

REL-GRD-1

1/2 - 5/8 " HYDRAULIC GROUND ROD DRIVER

42 X 4 PLCS
TORQUE TO
154 FTLBS

45 X 4PLCS

46 X 2 PLCS
TORQUE TO
200 INLBS

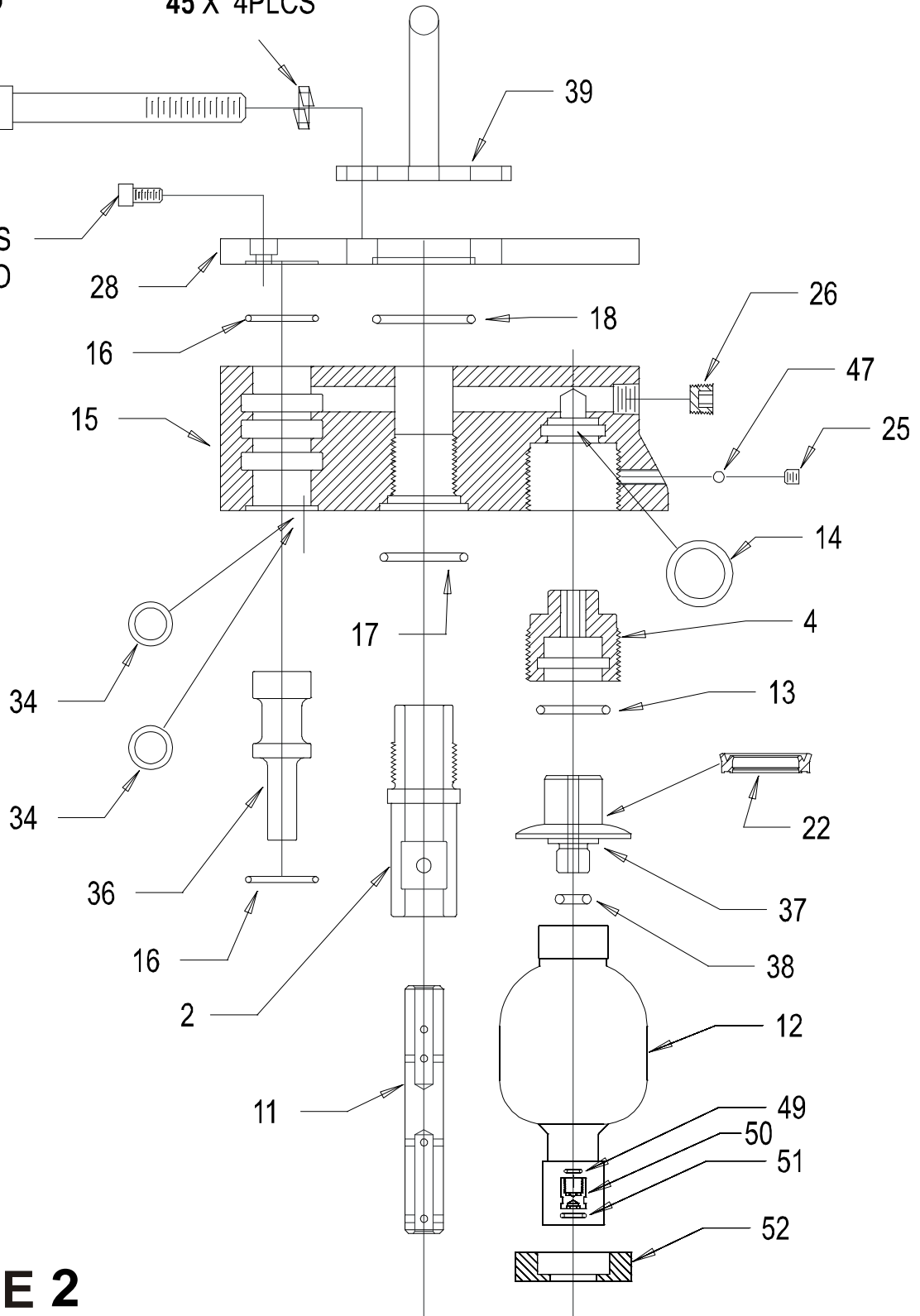
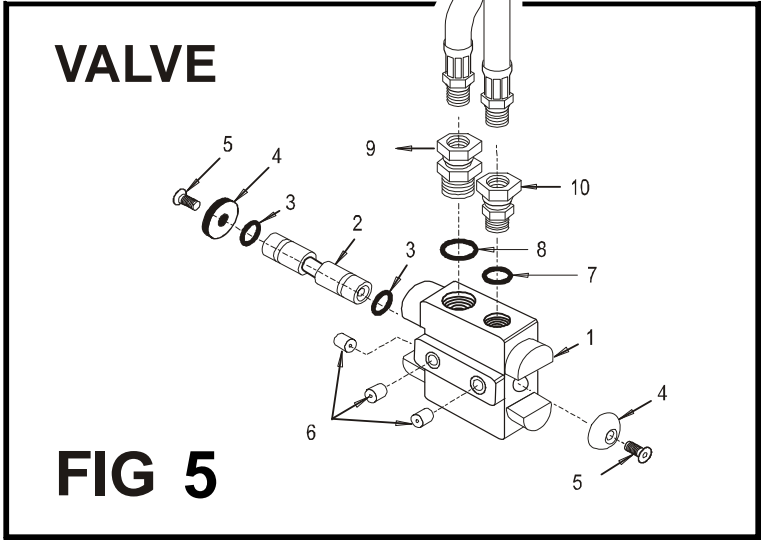
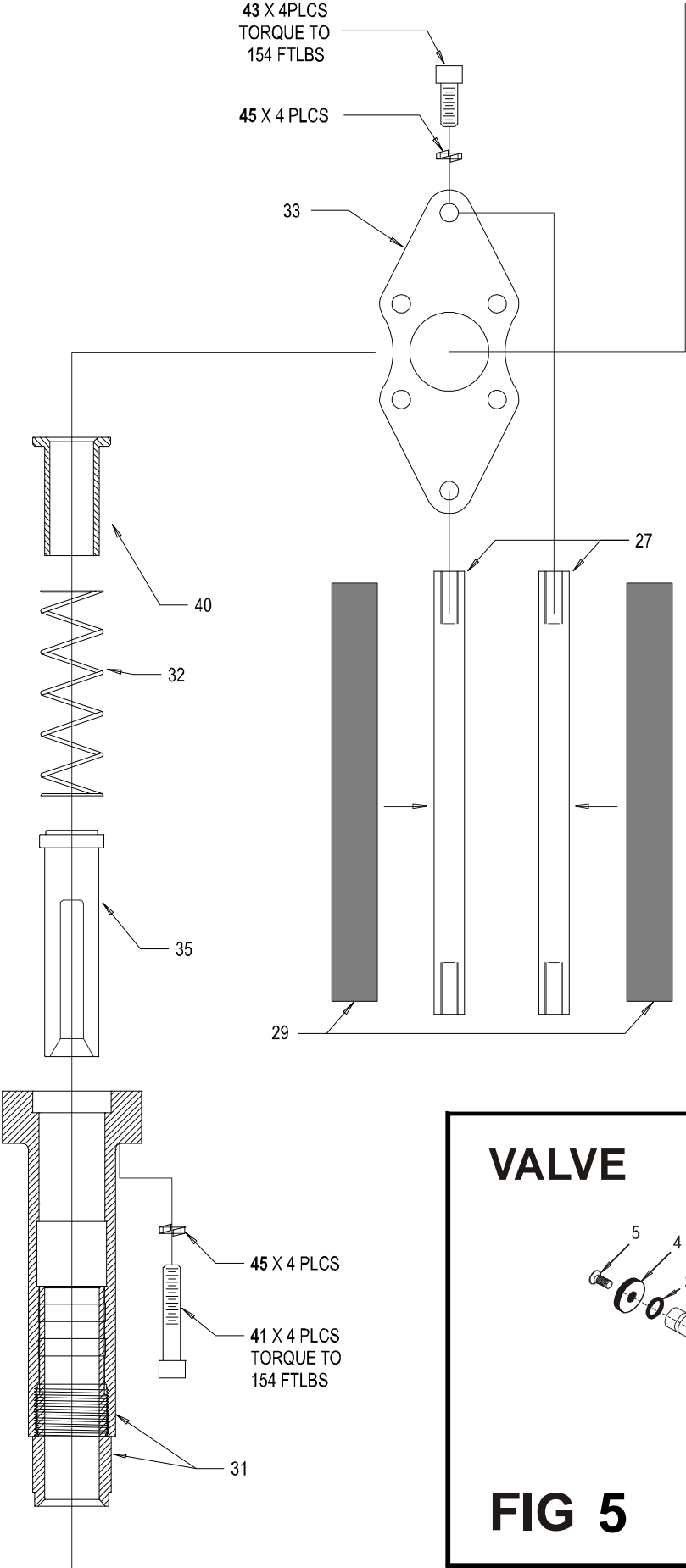

FIGURE 2

FIGURE 4



REL-GRD-1 - GROUND ROD DRIVER - Parts List

ITEM	PART #	QTY	DESCRIPTION	DRAWING
1	R48001	1	BODY	FIG. 2
2	R48002	1	BUSHING, PISTON	FIG. 1
3	R48003	1	END PLUG	FIG. 2
4	R48004	1	INSERT	FIG. 1
5	R48005	1	SPRING, SHUTTLE	FIG. 2
6	R48006	1	SHUTTLE SPOOL	FIG. 2
7	R48007	1	PLUNGER	FIG. 2
8	R48008	1	BUSHING, PLUNGER	FIG. 2
9	R48009 *	1	O-RING, PLUNGER BUSHING	FIG. 2
10	R48010 *	1	O-RING, END PLUG	FIG. 2
11	R48011	1	PISTON	FIG. 1
12	R48012	1	ACCUMULATOR	FIG. 1
13	R48013 *	1	O-RING, INSERT	FIG. 1
14	R48014 *	1	O-RING, VALVE BODY	FIG. 1
15	R48015	1	VALVE BODY	FIG. 1
16	R48016 *	2	O-RING, VALVE BODY	FIG. 1
17	R48017 *	1	O-RING, VALVE BODY	FIG. 1
18	R48018 *	1	O-RING, VALVE BODY	FIG. 1
19	R48019	1	GLAND	FIG. 2
20	R48020 *	2	O-RING, GLAND	FIG. 2
21	R48021 *	2	BACK-UP RING	FIG. 2
22	R48022 *	3	U-CUP	FIG. 1 & FIG. 2
23	R48023 *	1	WIPER	FIG. 2
24	R48024	1	RAM	FIG. 2
25	R48025	2	SET SCREW, 1/4 LG	FIG. 1 & FIG. 2
26	R48026	5	PLUG	FIG. 1 & FIG. 2
27	R48027	2	ROD, HANDLE	FIG. 3
28	R48028	1	END CAP	FIG. 1
29	R48048	2	CUSHION GRIP	FIG. 3
31	R48031	1	FRONT HOUSING, ASSY	FIG. 3
32	R48032	1	SPRING, FRONT HOUSING	FIG. 3
33	R48033	1	PLATE, FRONT HOUSING	FIG. 3
34	R48034 *	2	O-RING, VALVE BODY	FIG. 1
35	R48035	1	ANVIL, 5/8 INCH	FIG. 3
	R48075	1	ANVIL, 3/4 INCH	FIG. 3
	R48076	1	ANVIL, 1 INCH	FIG. 3
36	R48036	1	VALVE SPOOL	FIG. 1
37	R48037	1	PLUG, ACCUMULATOR	FIG. 1
38	R48038 *	1	O-RING, ACCUMULATOR PLUG	FIG. 1
39	R48039	1	LIFTING PLATE	FIG. 1
40	R48040	1	SLEEVE	FIG. 3
41	R48041	4	SCREW, FRONT HOUSING 2-3/4 LG	FIG. 3
42	R48042	4	SCREW, LIFTING PLATE 4 LG	FIG. 1
43	R48043	4	SCREW, HANDLE 1-1/4 LG	FIG. 3
44	R48044	1	PLUG, ACCUMULATOR	FIG. 2
45	R48045	12	LOCK WASHER	FIG. 1 & FIG. 3
46	R48046	2	SCREW, END CAP 1/2 LG	FIG. 1
47	R48047	2	PLASTIC BALL	FIG. 2
49	R48049 *	1	O-RING, NITROGEN SEAL	FIG. 2
50	R48050	1	NITROGEN SEAL	FIG. 2
51	R48051	1	SHOCK ABSORBER, ORING	FIG. 2
52	R48052	1	DAMPENER	FIG. 2
*	R48100	1	SEAL KIT (* ITEMS INCLUDED)	

R27600 - IN LINE REMOTE ON/OFF VALVE - Parts List

1	VALVE BODY	1	R27601
2	SPOOL	1	R27602
3	O-RING	2	R27052
4	BUTTON	2	13138
5	SCREW	2	13139
6	PIPE PLUG	3	12791
7	O-RING	1	R27030A
8	O-RING	1	R27074
9	RETURN LINE ADAPTER (LARGE)	4	R27073
10	PRESSURE LINE ADAPTER	2	R27071
11	HOSE ASSEMBLY, OUTSIDE (70 inches)	1	R48150
12	HOSE ASSEMBLY, INSIDE (69 inches)	1	R48151
13	PORT ADAPTER	2	R48060

TESTING AND CHARGING THE ACCUMULATOR

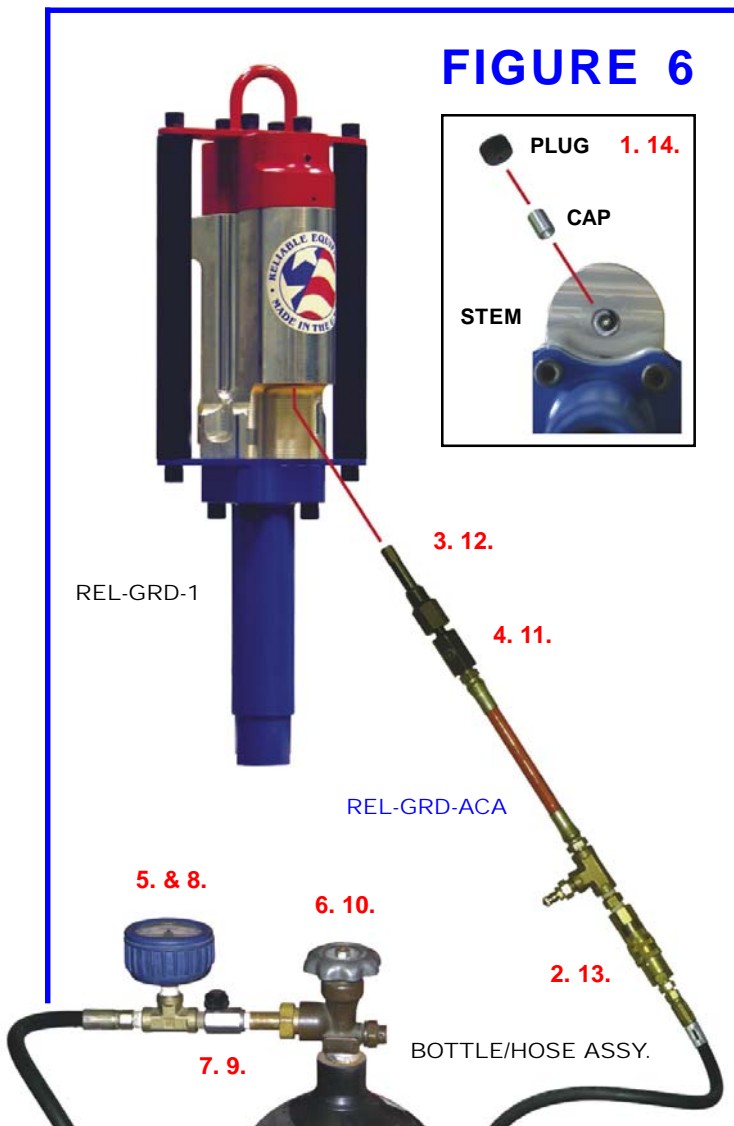

Testing or charging the accumulator will require charging assembly REL-GRD-ACA A **NITROGEN** bottle with Valve and Gauge. (min. 800 psi / 56 bar charge required) A length of compatible hose adequate to perform the tasks described without stretching or kinking the hose or assembly.

INSTRUCTIONS

1. Remove the Plug and Cap located at Tool Body bottom, opposite couplers.
2. Connect the Charging Assembly to the Hose / Bottle Assembly.
3. Thread the Charging Assembly onto the Accumulator Stem.
4. Tighten Swivel.
5. Check Pressure Gauge. (600 PSI Min.) If pressure is below 600 psi continue.
6. Turn on the Valve on NITROGEN Bottle.
7. Open In-Line Valve slowly.
8. Observe Gauge and fill to 650 psi.
9. Turn OFF supply at In-Line Valve.
10. Turn Off supply at the Bottle.
11. Release Swivel
12. Remove Assembly from Stem.
13. Remove Assembly from Hose / Bottle.
14. Replace Stem Cap and Plug.

TROUBLE SHOOTING

Determine the source (i.e. tool or hydraulic system) **of the problem before trouble shooting.**

NOTE: A mischarged accumulator may contribute to a variety of tool inconsistencies. Please refer to the **Accumulator Recharging Procedures** on page ____ of this manual.

Will not run

Ram is restricting hydraulic fluid	Apply light load to Ram by placing tool onto rod and raising to the verticle position.
Improper power source	Verify power source meets specifications
Low hydraulic fluid	Check fluid level
Incorrect viscosity	Use recommended fluid
Tool damaged	Disassemble and replace damaged parts
Hoses incorrectly connected	Switch hoses (<i>see hose connection in this manual</i>)
Dirt in tool	Disassemble, clean and repair

Tool runs slow

Power supply not functioning correctly	Reset to operator manual specs.
Fluid not warmed to correct temp	Allow tool a warm-up period
Fluid viscosity too high	See recommended viscosity
Air in hydraulic system	Check hoses for breaks, leaks, or loose connections
Hydraulic fluid level low	Fill to level. Check for leaks
Tool components loose	Tighten component hardware
Worn or damaged components	Replace worn or damaged components

Tool runs too fast

Power supply not functioning correctly	Reset to operator manual specs.
Excessive downward pressure	Do not apply downward pressure.

Tool operation is erratic

Hydraulic fluid not warm	Allow oil to warm up
Dirt or contaminants in tool	Clean and reassemble
Air in system	Check hoses for breaks, leaks, or loose connections

Tool runs continuously

Tool locked in "ON" position	Release trigger lever lock
------------------------------------	----------------------------

Valve operation is difficult

Tool valve spool dirty	Clean up spool so that spool slides freely
Components worn or damaged	Replace damaged components

Tool runs hot

Low fluid level	Fill pump reservoir to correct level
Fluid viscosity incorrect	Use recommended fluid
Fluid dirty	Drain tank, flush, and replace fluid
Power supply not functioning correctly	Reset to operator manual specs
Worn or damaged O-rings or gaskets	Replace worn or damaged components
Hydraulic fluid level low	Fill to level. Check for leaks

Tool is erratic

Hydraulic fluid not warm	Allow oil to warm up
Dirt or contaminants in tool	Clean and reassemble
Air in system	Check hoses for breaks, leaks, or loose connections

Tool leaks hydraulic fluid

Worn or damaged seals	Disassemble and replace worn or damaged seals
Components loose	Tighten component hardware

Tool lacks power

Control valve leaking	Worn part or seal rings
-----------------------------	-------------------------

READ BEFORE DISASSEMBLY



WARNING

Safety

DO NOT attempt to make any changes to any of the component parts or accessories when connected to the power source.

DO NOT adjust, inspect, or clean tool while the tool is connected to the power source. The tool could accidentally start up and cause serious injury.



WARNING

Before disassembly, disconnect hoses as described in this manual. Any residual pressure within the unit can and will spray at high velocity, injuring the person doing the disassembly. Hot or pressurized hydraulic fluid will cause serious injury or death.

Complete disassembly is not recommended. Return the unit to an authorized dealer for total disassembly and/or repair.

All maintenance or disassembly should take place on a flat, clean work surface covered with towels or wipers so as to have a clean space for the disassembled parts. Inspect each part during disassembly for wear, scratches, and cuts. Discard the worn or damaged parts and replace with new factory authorized parts.

O-rings are sensitive to sharp edges. Inspect closely for cuts or damage. A small cut will cause a leak. When assembling or disassembling O-rings, use hydraulic fluid as a lubricant to aid disassembly or installation.

The REL-GRD-1 is dedicated to the memory of Doug Phillips.

“The Doogie Driver”

Doug Phillips was a dedicated salesman, and a long time advocate for the production of a RELIABLE Ground Rod Driver.

We are sorry that Doug never got to introduce this tool to his customers, but we are convinced that the “Doogie Driver” will live up to his expectations.



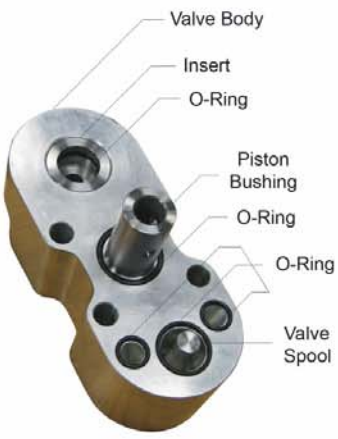

NOTE
 Orientation of Piston must be as shown





WARNING

Operation/Safety methods may vary in accordance with the working guidelines established by each Utility or Contractor.

For your own safety, ensure that you fully comply with all safe operation guidelines required by your employer.



MAINTENANCE RECORD

Date	Parts or Service Required

If you have any questions regarding the information in this manual please contact **RELIABLE EQUIPMENT** at the address, phone or fax numbers shown below.



RELIABLE EQUIPMENT & SERVICE CO., INC.

92 Steamwhistle Drive • Ivyland, PA 18974
Phone: 800-966-3530 • Fax: 215-357-9193
Visit us on the web at www.Reliable-Equip.com