

# OPERATORS' GUIDE

REL-LP-1.5-B



REL-LP-K-B

## REL-LP-B SERIES

12 TON HYDRAULIC CRIMPING TOOLS

### WARNING



All information found in this guide must be read and understood before use or testing of this tool.

Failure to read and understand these warnings and safe handling instructions could result in severe personal injury and or death.

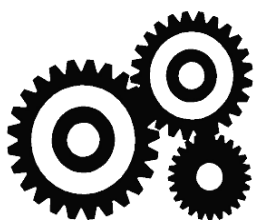

# RELIABLE EQUIPMENT & SERVICE CO., INC.

LP-12TN Manual 08-09

# DISTRIBUTED BY

## REGISTRATION

UPON RECEIPT OF THIS TOOL, COMPLETE THE REGISTRATION BELOW.

COMPANY \_\_\_\_\_

ADDRESS \_\_\_\_\_

\_\_\_\_\_

PHONE \_\_\_\_\_ FAX \_\_\_\_\_

SERIAL NUMBER \_\_\_\_\_

DATE OF PURCHASE \_\_\_\_\_

DEALER NAME \_\_\_\_\_



CAUTION

The information in this manual is intended to guide the user in the use and application of this tool. It is not intended as a substitute for proper training and experience in safe work practices for this type of equipment.

Consult your supervisor or safety personnel if you have any questions regarding the safe operation of this tool.

# TABLE OF CONTENTS

DISTRIBUTOR INFORMATION .....	2
REGISTRATION .....	2
TABLE OF CONTENTS .....	3
TOOL SPECIFICATIONS	
REL-LP-1.5-B .....	4
REL-LP-K-B .....	4
SAFETY INFORMATION AND WARNINGS .....	6-10
OPERATING INSTRUCTIONS .....	11
DIE INSTALLATION .....	12
DISCONNECTING HOSES .....	13
DAILY/GENERAL MAINTENANCE .....	14
INSPECTION AND TESTING .....	15
REL-LP-1.5-B HEAD ASSEMBLY (Drawing & Parts) .....	16
REL-LP-K-B HEAD ASSEMBLY (Drawing & Parts) .....	17
REL-LP-__-B BODY ASSEMBLY (Drawing) .....	18
REL-LP-__-B HANDLE ASSEMBLY (B) .....	19
PARTS LIST .....	20-21
MAINTENANCE RECORDS .....	22
CONTACT INFORMATION .....	22

If you have any questions regarding the information found in this manual please contact RELIABLE EQUIPMENT at 800-966-3530 or FAX 215-357-9193.



**THIS SYMBOL INDICATES ITEMS OF EXTREME IMPORTANCE.**

Safety of user and others may be in jeopardy if these instructions are not read and understood.

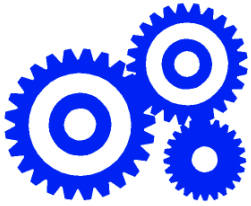

# RELIABLE EQUIPMENT & SERVICE CO., INC.

## REL-LP-1.5-B 12 TON, LOW PRESSURE, HYDRAULIC CRIMPING TOOL



Weight: 21 lbs. Dry  
Length: 19 in.

## REL-LP-1.5-B 12 TON, LOW PRESSURE, HYDRAULIC CRIMPING TOOL

Operate from any 1,700-2,500 psi hydraulic power source. NO H/P intensifier needed. Smaller than many equivalent 12 ton low pressure crimping tools currently available. Crimp up to 750 MCM Copper or Aluminum. Operate on Open- or Closed- Center systems. Exchange head from 12 ton "U" Style to 12 ton Kearney style without removing from service, using optional die holder and Kearney style head.

12 ton Kearney Style tool is also available. Handle swivels 360° for easy positioning.

Accepts current "U" style die inventories from Reliable Equipment, Burndy, Alcoa, Anderson, and Thomas & Betts.

### SPECIFICATIONS

<b>System</b>	Open/Closed Center
<b>Force</b>	24,000 lb.
<b>Pressure</b>	1,700-2,500 psi
<b>Flow</b>	4-8 gpm
<b>Capacity</b>	1.5 inch (750 mcm Cu. and Al.)

\* Dies not included.

### RELIABLE EQUIPMENT & SERVICE CO., INC.

92 Steamwhistle Drive • Ivyland, PA 18974  
Phone: 800-966-3530 • Fax: 215-357-9193  
Visit us on the web at [www.Reliable-Equip.com](http://www.Reliable-Equip.com)

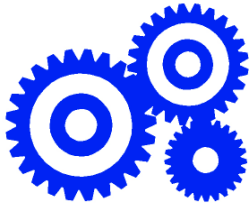

# RELIABLE EQUIPMENT & SERVICE CO., INC.

## REL-LP-K-B

### 12 TON, LOW PRESSURE, HYDRAULIC CRIMPING TOOL



Weight: 21 lbs. Dry  
Length: 19 in.

## REL-LP-K-B

### 12 TON, LOW PRESSURE, HYDRAULIC CRIMPING TOOL

Operate from any 1,700-2,500 psi hydraulic power source. NO H/P intensifier needed. Smaller than many equivalent 12 ton low pressure crimping tools currently available. Crimp up to 750 MCM Copper or Aluminum. Operate on Open- or Closed- Center systems. Exchange head from 12 ton Kearney Style to 12 ton Burndy "U" style without removing from service, using optional die holder and Burndy style head.

12 ton Burndy Style tool is also available. Handle swivels 360° for easy positioning.

Accepts current 12 ton Kearney style dies available from your Reliable Equipment sales representative.

### SPECIFICATIONS

<b>System</b>	Open/Closed Center
<b>Force</b>	24,000 lb.
<b>Pressure</b>	1,700-2,500 psi
<b>Flow</b>	4-8 gpm
<b>Capacity</b>	1.5 inch (750 mcm Cu. and Al.)

\* Dies not included.

### RELIABLE EQUIPMENT & SERVICE CO., INC.

92 Steamwhistle Drive • Ivyland, PA 18974  
Phone: 800-966-3530 • Fax: 215-357-9193  
Visit us on the web at [www.Reliable-Equip.com](http://www.Reliable-Equip.com)



**WARNING**

**BEFORE USING THIS TOOL, READ THE WARNINGS and the recommended practices described in this manual. Failure by the operator to read and fully understand these warnings will leave this person unqualified to use and operate this tool. Property damage, severe personal injury, and/or death could result by not following these warnings.**

These warnings will appear in appropriate locations when they are pertinent to the particular subject being shown. Read each one carefully and follow them strictly.



### **Eye Protection**

**WARNING**

**Always wear eye protection to avoid injury from flying debris or hydraulic oil leaks. Failure to do so can result in serious personal injury.**



### **Skin Irritation**

**WARNING**

**Hydraulic oil may cause irritation. Use care to prevent contact with skin. In case of accidental contact, wash affected area immediately**



### **Hard Hat**

**WARNING**

**Always wear a hard hat to avoid injury from falling debris. Failure to do so can result in serious personal injury.**



### **Foot Protection**

**WARNING**

**Always wear foot protection. Failure to do so can result in serious personal injury.**



### **Hearing Protection**

**WARNING**

**Always wear hearing protection, to avoid hearing loss due to long term exposure to high noise levels.**



### **Protective Gloves**

**WARNING**

**Always wear protective gloves. Failure to do so can result in serious personal injury.**



WARNING

## CRIMP DANGER

This hydraulic crimping tool can crush and/or disable. **KEEP ALL PARTS OF THE BODY AWAY FROM MOVING PARTS. DO NOT lock the tool in the On Position. In an emergency, serious damage or injury could occur during the time required to stop the tool.**  
Failure to observe this warning could result in serious injury



WARNING

## SERIOUS BURN HAZARD

**HOT SURFACES MAY CAUSE SERIOUS BURNS.**  
The hydraulic cylinder may be hot during and after operation. **CAUTION: HYDRAULIC FLUID MAY CAUSE SERIOUS BURNS.**  
Never disconnect tool, hoses, or fittings while the hydraulic power source is running or if the hydraulic fluid is hot.  
Failure to observe this warning could result in serious injury.



WARNING

## FIRE HAZARD

An incomplete crimp may pose a fire hazard.  
Always use the appropriate connector, die set, and compression tool, as required by the intended application.  
When the pressure relief valve sounds, the crimp tool has reached maximum pressure, and the crimp is complete.  
Compression tool should be tested on a regular schedule to ensure pressure relief valve activates at the proper pressure.  
Failure to observe this warning could result in serious injury.



WARNING

## TOOL HAZARD

**DO NOT OPERATE TOOL WITHOUT DIES.**  
**DO NOT EXCEED THE MAXIMUM HYDRAULIC FLOW, RELIEF PRESSURE, OR BACK PRESSURE.**  
Failure to observe warnings could result in tool damage or injury.



WARNING

## SAFE OPERATION & CARE

**USE THIS TOOL FOR ITS INTENDED PURPOSE ONLY**  
Any other use can result in personal injury or property damage.

**INSPECT TOOL BEFORE USE.** Replace any worn, damaged or missing parts. A damaged or improperly assembled tool may malfunction, injuring operator and/or nearby personnel.

**INSPECT HYDRAULIC HOSES AND COUPLINGS** before each use. Repair or replace if any cracking, leakage, wear or damage is found. Worn or damaged hoses may fail resulting in personal injury or property damage.

**CLEAR WORK AREA** of all bystanders and unnecessary personnel before operating this tool.

**KEEP ALL PARTS OF THE BODY AWAY FROM MOVING PARTS.**

Failure to observe this warning could result in serious injury.



WARNING

## HYDRAULIC POWER SUPPLY

**DO NOT** attempt to make any changes to any of the component parts or accessories when connected to the power source.

**DO NOT** adjust, inspect, or clean tool while the tool is connected to the power source. The tool could accidentally start up and cause serious injury.

**DO NOT** lock the tool in the On Position. In an emergency, serious damage or injury could occur during the time required to stop the tool.



WARNING

## OIL INJECTION INJURY

Hydraulic oil or fluid under the skin is a serious injury. Oil under pressure can penetrate the skin and may cause dismemberment or loss of life. Seek medical assistance immediately if such an injury should occur.

Always wear safety gloves, eye protection and all required safety equipment when operating or handling this tool.

**DO NOT** use fingers or hands to attempt to locate a leak.

**DO NOT** handle hoses or couplers while system is pressurized.

**NEVER** open or service the system before depressurizing.



WARNING

## HOSES AND FITTINGS

There exists the potential for shock in using anything other than certified nonconductive hoses and hydraulic oil with dielectric properties, when using system components near energized electrical lines. Failure to recognize these conditions could cause electrocution.

Hoses and fittings used with this tool must comply with S.A.E. J1273 which covers recommended practice for selection, installation, and maintenance of hose and hose assemblies. The **correct hoses and fittings are available from your supplier.**

**WARNING:** Failure to comply with these warnings could result in severe bodily injury.



WARNING

## UNIT/HOSE CONNECTIONS

**ALWAYS DISCONNECT** pump/power source and move toggle switch to **OFF** before connecting or disconnecting any components.

**ALWAYS DEPRESSURIZE** hydraulic system, before slowly disconnecting this unit or any of the systems components.

**ALWAYS TIGHTEN** couplings completely. Loose or improperly tightened couplings will not allow fluid to pass through the hose creating a blockage in the supply or return line.

**ALWAYS INSPECT HOSES AND CONNECTORS** before connection to tool. Replace or repair if any leakage is evident. Leakage is a sign of deterioration in component parts. Worn or leaking parts must be repaired or replaced, or tool damage and/or severe injury could result.



CAUTION

## HOSE INSTALLATION

### **ALWAYS ENSURE CONNECTORS ARE CLEAN**

Care must be taken to assure the correct connection of the hoses to the pressure and return (tank) ports.

Connect the return hose to the return (tank) port on the power source, then to the return port on the tool.

Connect the pressure hose to the pressure port on the tool, then to the "P" pressure port on the power source.

Operation with hydraulic flow reversed can cause malfunction. Failure to fully comply can result in severe injury or death.



WARNING

Operation/Safety methods may vary in accordance with the working guidelines established by each utility or contractor.

For your own safety, ensure that you fully comply with all safe operation guidelines required by your employer.



WARNING

## ELECTRICAL SHOCK HAZARD

Always wear and use the necessary clothing, equipment and safety practices to protect against electrical shock. Failure to follow these rules can result in serious personal injury or death.



## GENERAL SAFETY



**USE ALL APPROPRIATE AND APPLICABLE PERSONAL SAFETY EQUIPMENT** as required by the operating company.

**INSPECT TOOL BEFORE USE.** Replace any worn, damaged or missing parts. A damaged or improperly assembled tool may injure operator and/or nearby personnel.

**KEEP ALL PARTS OF THE BODY AWAY** from moving parts of the tool.

**KEEP HANDS OUT FROM BETWEEN CRIMPING JAWS AT TOOL HEAD.**

**ALL BODY PARTS SHOULD BE OUTSIDE DANGER ZONE PRIOR TO CRIMPING.**

**MAKE SURE** there is no person in close proximity to you or the tool who could be injured by any operation being performed, tool malfunction or flying debris.

**DO NOT OVEREXTEND** your position by overreaching or unbalancing the footing necessary to maintain physical control of your body and the tool.

**ALWAYS MAINTAIN** a firm grip on the tool to avoid loss of control during an operation, causing property damage, serious injury or death.

**USE THIS TOOL FOR THE MANUFACTURERS' INTENDED PURPOSE ONLY.**

**OBSERVE CLOSELY ALL SAFETY RULES FOR A PARTICULAR JOB CLASS**

**FAILURE TO HEED THESE WARNINGS COULD RESULT IN PROPERTY DAMAGE, SERIOUS PERSONAL INJURY OR DEATH.**

# OPERATION

Read entire manual prior to using this tool.

(Refer to all safety recommendations and warnings)

Observe all safety precautions and procedures required by the operating company.

(Also refer to SAFETY information found on pages 6 through 10)

## Select Open-Center or Closed-Center (No tools Required)

1. The person operating the tool must know the type of hydraulic system on which the tool is being used.
2. On the top of the handle body, just in front of the OC/CC knob, there is an arrow cast into the body. For open-center systems, the "O" on the Knob should be aligned with the marking, and for closed-center systems the "C" is aligned.
3. While using the tool, the operator should check the OC/CC alignment frequently in the event it becomes inadvertently disoriented.

Before crimping, ensure that crimp is within the capacity listed for the tool.

Refer to connector manufacturer's instructions for cable preparation and crimping procedure.

Ensure that you are using the proper die, as recommended by the connector manufacturer.

Insert proper die into die seat. Refer to appropriate **DIE INSTALLATION** on next page.



## NEVER OPERATE TOOL WITHOUT DIES

Serious damage or personal injury could occur.



Place tool over connector. Center connector between the dies.

Align jaw as necessary to ensure proper crimp.

Press the trigger to advance the dies.

Compress trigger partially for slow advance.

Compress trigger completely for fast advance.

**NOTE:** Jaw may be released as needed at any point in the crimp cycle.

Continue cycle until pressure has been achieved. Crimp is complete.

Ram will retract automatically when trigger is released.

Repeat steps above as specified by connector manufacturer.

To reduce heat and wear on tool components, stop the power source, when the tool is not in use.

Manufacturer recommends regular testing for proper pressure and operation.

Test at least every 6 months, test more often under heavy usage.

**IF YOU HAVE ANY QUESTIONS REGARDING THE PROPER USE  
AND/OR OPERATION OF THIS TOOL, CONSULT YOUR AREA SUPERVISOR,  
OR CONTACT RELIABLE EQUIPMENT AT 800-966-3530**

# DIE INSTALLATION

Observe safety precautions and procedures required by the operating company.

Turn flow control lever to the OFF position.

Turn hydraulic power source OFF.

Ensure crimp is within the capacity for the tool.

Refer to connector manufacturer's instructions for cable preparation and crimping procedure.

Ensure that you are using the proper die, as recommended by the connector manufacturer.

## REL-LP-1.5-B

**Inserting die half into upper die retainer.**

Pull up on the die retainer knob.

Slide the die half beneath the upper retaining lip.

Release retainer knob.

Check to ensure die is securely seated.

**Inserting die half into lower die retainer.**

Compress/push lower die button on ram.

Slide the die half beneath the lower retaining lip.

Release retainer button.

Check to ensure die is securely seated.

## REL-LP-K-B

**INSERT DIE HALF INTO UPPER RETAINER**

Insert the die in to the upper die button receiver.

Tighten retaining screw on front of head.\*

Check to ensure die is securely seated.

**INSERT DIE HALF INTO LOWER RETAINER**

Insert the die in to the lower die button receiver.

Tighten retaining screw.\*

Check to ensure die is securely seated.

\*Hex driver supplied

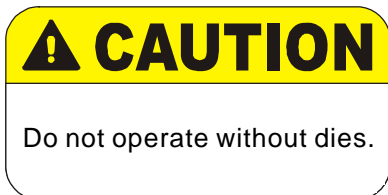
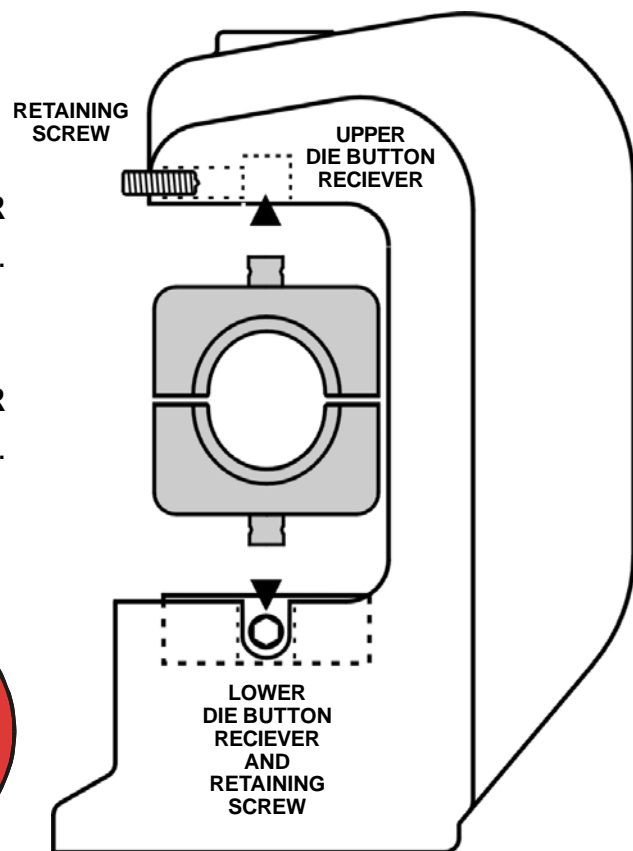
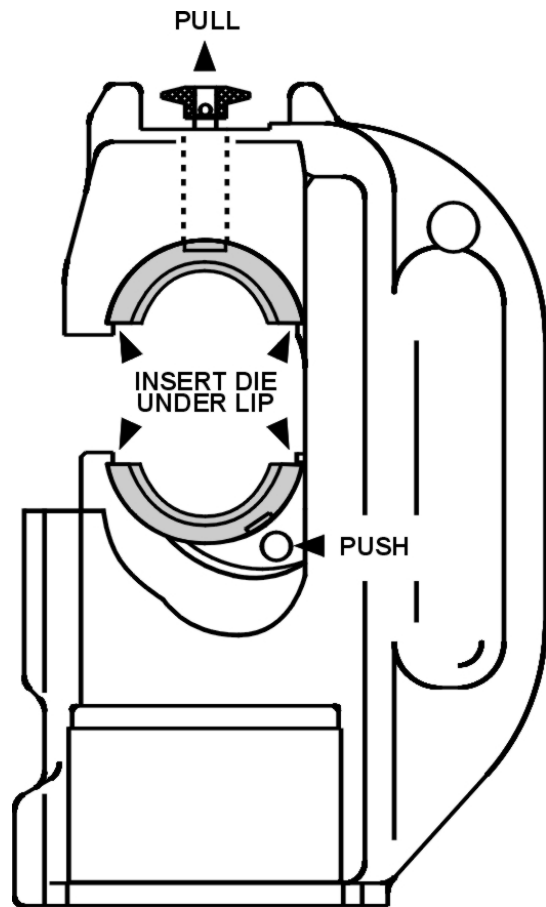



WARNING

## SERIOUS BURN HAZARD

**HOT SURFACES MAY CAUSE SERIOUS BURNS.**

The hydraulic cylinder may be hot during and after operation.

**CAUTION: HYDRAULIC FLUID MAY CAUSE SERIOUS BURNS.**

Never disconnect tool, hoses, or fittings while the hydraulic power source is running or if the hydraulic fluid is hot.

Failure to observe this warning could result in serious injury.



CAUTION

## DISCONNECTING HOSES

**ALWAYS CAP HOSE & TOOL CONNECTORS WHEN NOT IN USE**

Turn flow control lever to the **OFF** position.

Turn hydraulic power source **OFF**.

**CAUTION: TOOL AND/OR HYDRAULIC FLUIDS MAY BE HOT.**

**CAUTION: TOOL/HOSES MAY STILL BE UNDER PRESSURE.**

Follow the sequence below to prevent pressure buildup.

Loosen all connections slowly in case pressure has built up.

Disconnect the pressure hose from the power source.

Disconnect the pressure hose from the tool.

Disconnect the return/tank hose from the tool.

Disconnect the return/tank hose from the power source.

**Failure to fully comply could result in severe injury or death.**



WARNING

## HOSE/CONNECTOR INSPECTION

**ALWAYS DISCONNECT** pump/power source and move toggle switch to **OFF** before connecting or disconnecting any components.

**ALWAYS DEPRESSURIZE** hydraulic system, before slowly disconnecting this unit or any of the systems components.

**ALWAYS INSPECT HOSES AND CONNECTORS.** Replace or repair if any leakage is evident. Leakage is a sign of deterioration in component parts. Worn or leaking parts must be repaired or replaced.

Loose or improperly tightened couplings will not allow fluid to pass through the hose creating a blockage in the supply or return line.

**Failure to fully comply can result in severe injury or death.**

# DAILY MAINTENANCE

The life, reliability, and safety of the tool is dependent on proper maintenance. Clean all surfaces including head, die seat, ram, and body.

Install dust caps over the hydraulic ports when tool is disconnected.

Inspect tool, hoses, and couplers for leaks, cracks, wear, and damage.

Worn or damaged parts may malfunction during operation.

**All parts must be replaced with new parts if signs of wear or damage are evident.**

Keep Label Set clean and legible. Replace decals when necessary.



**WARNING**

BEFORE USING THIS PRODUCT READ THE SAFETY WARNINGS and recommended practices described in the manual. Failure by the operator to read and fully understand the warnings will leave this person unqualified to use and operate the tool.

Failure to observe all warnings and instructions could result in property damage, severe personal injury, and/or death.



**CAUTION**

Operation and safety methods may vary in accordance with the guidelines established by each utility. For your safety, ensure that you fully comply with all safe operation guidelines established by your respective power utility.

REL-SM

**DANGER**

 The user should be properly trained in the correct procedures required for work on or around electrical lines.

**CAUTION**

Do not operate without dies.

## GENERAL MAINTENANCE

**Complete disassembly is not recommended. Return the unit to an authorized dealer for total disassembly and/or repair.**

All maintenance or disassembly should take place on a flat, clean work surface covered with towels or wipers so as to have a clean space for the disassembled parts.

Inspect each part during disassembly for wear, scratches, and cuts. Discard the worn or damaged parts and replace with new factory authorized parts. *See parts drawings on pg16-20.*

O-rings are sensitive to sharp edges. Inspect closely for cuts or damage. A small cut will cause a leak. When assembling or disassembling O-rings, use hydraulic fluid as a lubricant to help disassembly or installation.

When disposing of hydraulic parts or components observe all federal, state, and local guidelines.

**IF YOU HAVE QUESTIONS REGARDING THE REPAIR AND MAINTENANCE OF THIS TOOL CONTACT RELIABLE EQUIPMENT AT 800-966-3530**

# INSPECTION AND TESTING

## MONTHLY

Perform a thorough inspection of the hydraulic hoses and fittings as described in Publication SAE J1273 Hose and Hose Assemblies.

Apply a light oil to all moving parts.

## QUARTERLY OR EVERY 500 CRIMPS

Perform a Pressure Relief Valve Check, to ensure proper pressure/activation of the pressure relief valve.

Test the crimping tool with a Reliable Load Cell part #REL-CG-12TN, and test dies part #R12-TD.

## USING THE REL-CG-12TN - LOAD CELL

Insert or install appropriate test die set Part #R12-TD. (See Die Installation on page #12)

Insert Load Cell between test dies.

Perform a test crimp.

Pressure relief should occur at 9,500-10,500 psi on gauge. (Equivalent to 12 ton)

If pressure relief occurs outside of the specified range, send the crimping tool to an Authorized Reliable Service Center.

## ANNUALLY

If required by the regulations of your employer, organization, or safety committee guidelines, send the crimping tool to an Authorized Reliable Service Center for testing and evaluation.



WARNING

Inspection & Testing requirements may vary in accordance with the working guidelines established by each utility or contractor.

For your own safety, ensure that you fully comply with all safe operation guidelines required by your employer.

**IF YOU HAVE QUESTIONS REGARDING THE TESTING AND MAINTENANCE OF THIS TOOL CONTACT RELIABLE EQUIPMENT AT 800-966-3530**

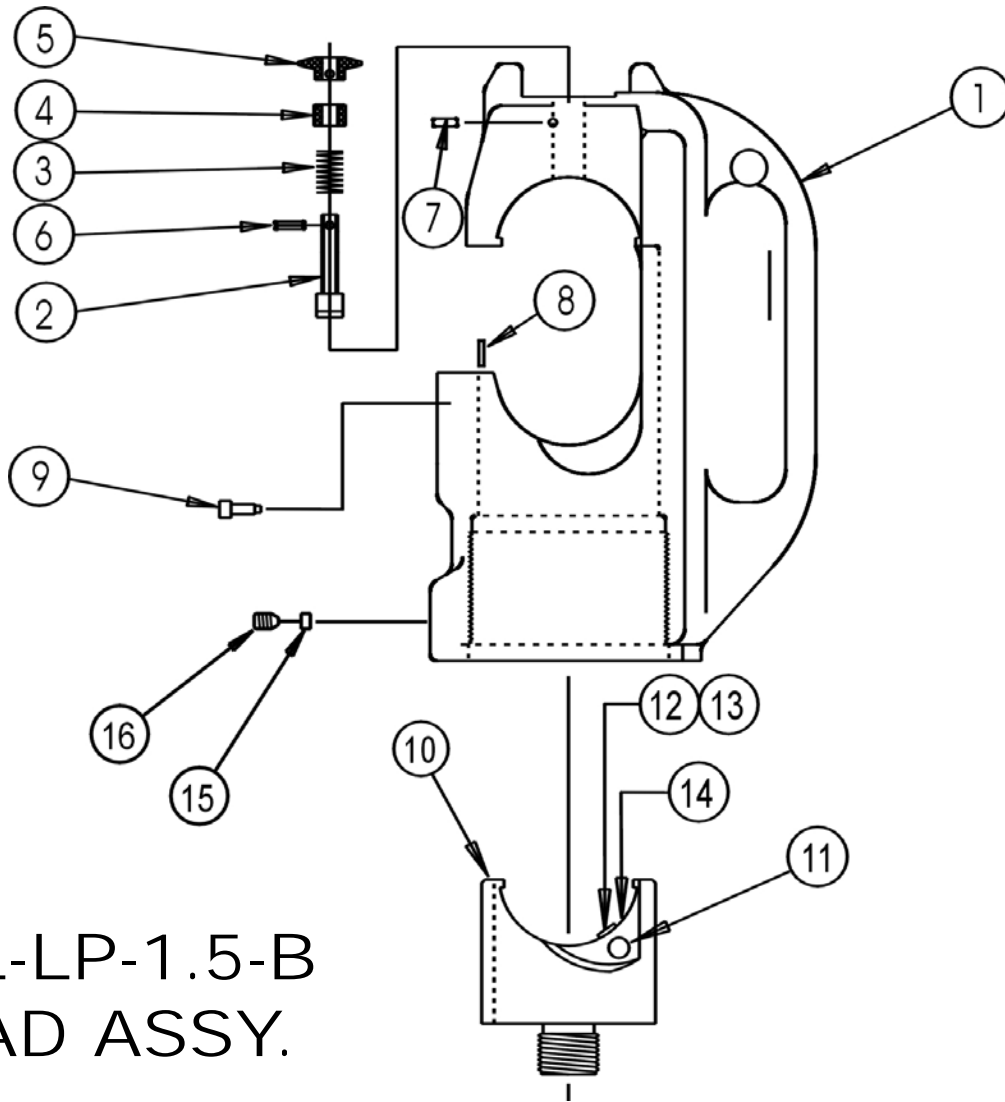

# REL-LP-1.5-B HEAD ASSY.

ITEM	PART	QTY	DESCRIPTION
1	R19100	1	C-FRAME
2	1220-5	1	DIE RETAINING PIN
3	1220-4	1	SPRING
4	1220-3	1	SCREW WITH THRU HOLE
5	1220-20D	1	KNOB
6	1220-16	1	DRIVE PIN
7	R19053	1	PIN
8	1220-6	1	RAM ROTARY KEY
9	1220-7	1	LOCKING SCREW
10	R32030	1	DIE HOLDER, U-DIE
11	R13810	1	DIE BUTTON
12	R13817	1	SPRING
13	R13811	1	DIE RETAINER
14	R13813	1	SPRING PIN
15	R28026	1	PLASTIC INSERT
16	R28025	1	SET SCREW

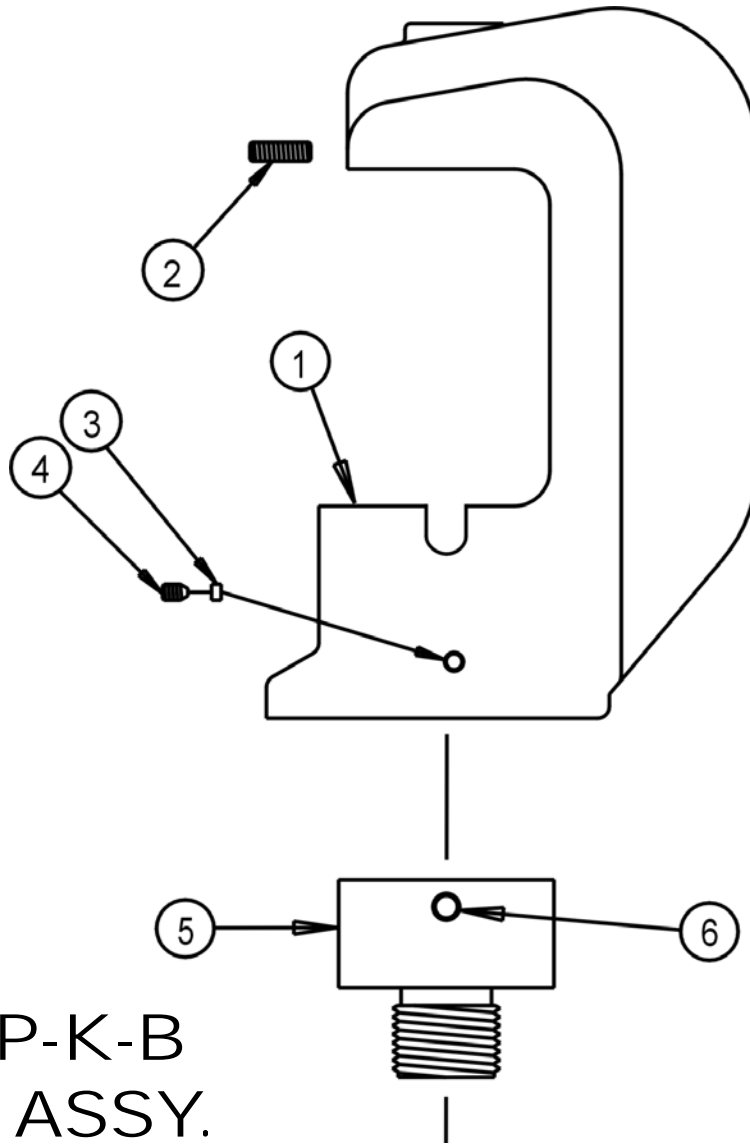

REL-LP-K-B  
HEAD ASSY.

ITEM	PART	QTY	DESCRIPTION
1	R28030	1	C-FRAME
2	R28021	1	SET SCREW (DIE RETAINER)
3	R28026	1	PLASTIC INSERT
4	R28025	2	SET SCREW
5	R32031	1	DIE HOLDER, KEARNY STYLE
6	R21024	1	SET SCREW (DIE RETAINER)
	R32133	1	SLOTTED SET SCREW (OPTIONAL)

**IF YOU HAVE ANY QUESTIONS REGARDING PARTS  
OR SERVICE OF THIS TOOL, CONSULT YOUR AREA SUPERVISOR,  
OR CONTACT RELIABLE EQUIPMENT AT 800-966-3530**

# REL-LP-\_\_-B Body Assembly

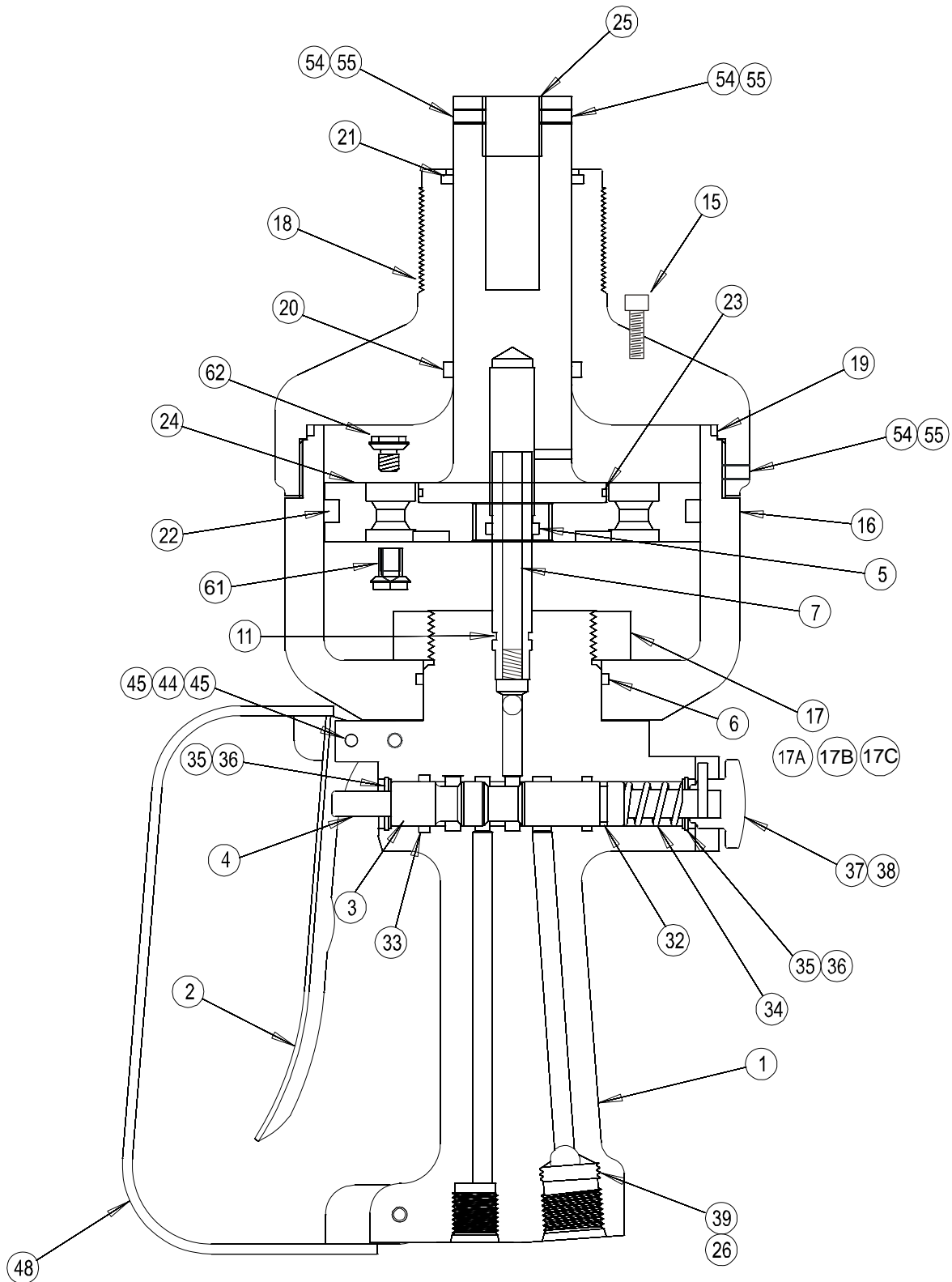

# REL-LP-\_\_-B Handle Assembly (B)

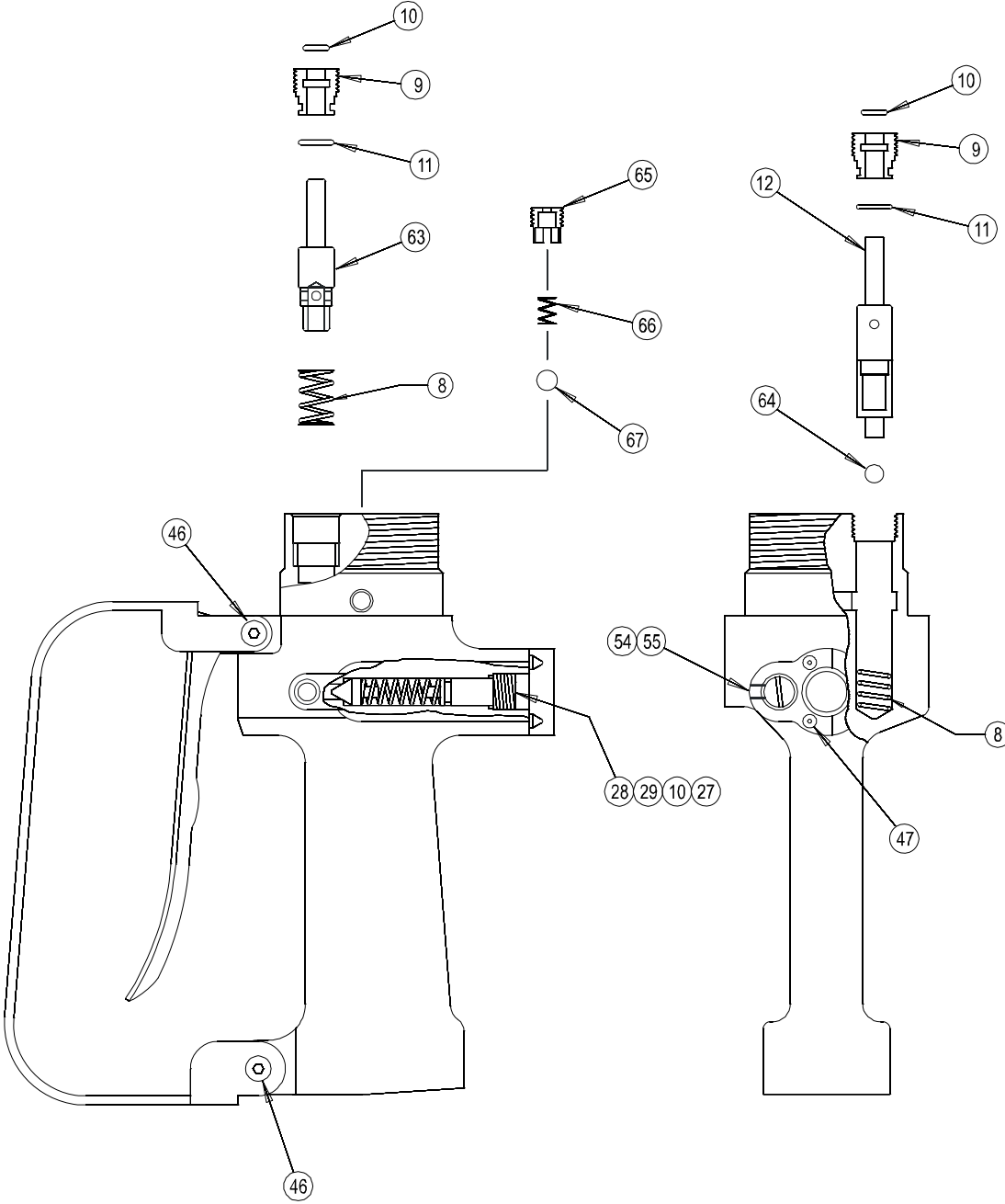

**IF YOU HAVE ANY QUESTIONS REGARDING THE PROPER OPERATION OR MAINTENANCE OF THIS TOOL, CONSULT YOUR AREA SUPERVISOR, OR CONTACT RELIABLE EQUIPMENT AT 800-966-3530**

## REL-LP-\_\_-B PARTS LIST

KEY #	PART #	QTY	DESCRIPTION
1	32701	1	HANDLE
2	32002	1	TRIGGER
3	32003	1	MAIN SPOOL
4	32004	1	PLUG, SPOOL
5	32005	1*	O-RING
6	32006	1*	O-RING
7	32307	1	CENTER TUBE
8	32008	2	SPRING, CHECKASSY
9	32009	2	CAP, PLUNGER
10	32010	3*	O-RING
11	32011	3*	O-RING
12	32055	1	PLUNGER ASSY
15	R32306	1	HEAD STOP SCREW
16	32016	1	CYLINDER, 12 TON
17	32017	1	LOCKING RING
17A	32042	1	SCREW, LOCKING RIN
17B	32043	1	LOCKING PIN
17C	32044	1	PLASTIC WAFER
18	32018	1	NOSE, 510 STYLE
19	32019	1*	O-RING, CYL NOSE
20	32020	1*	O-RING, NOSE RAM
21	32021	1*	WIPER
22	32022	1*	SEAL, DISK
23	32023	1*	O-RING, PAM
24	32060	1	DISK
25	32025	1	RAM, 12 TON
26	32026	1	CHECK STOP
27	32027	1	ADJUSTING NUT
28	32028	1	PINTLE
29	32029	1	SPRING, REGULATOR
32	13133	1*	O-RING

REL-LP-\_\_-B PARTS LIST *Continued . . .*

KEY #	PART #	QTY	DESCRIPTION
33	13134	1*	O-RING
34	10109	1	SPRING, MAIN
35	13115	2	RETAINING WASHER
36	13116	2	RETAINING SPRING CLIP
37	13171	1	OC/CC KNOB
38	13136	1	SPRING PIN
39	12744	1	BALL 3/8 DIA.
44	13430	1	TRIGGER PIN
45	13457	2	C-CLIP
46	13441	4	SCREW
47	13156	2	PIN
48	32034	1	GUARD
50	12791	4	NPT PLUG, 1/16
51	32035	1	NPT PLUG, 1/8
54	32125	4	SET SCREW
55	32126	4	PLASTIC INSERT
61	32061	2	POPPET BODY
62	32062	2	POPPET TOP
63	32073	1	SHUT OFF PLUNGER
64	18048	1	1/4 BALL
65	18020	1	CHECK CAP
66	18039	1	SPRING (UPPER CHECK)
67	18051	1	9/32 BALL

32050	1*	SEAL KIT
* DENOTES ITEMS IN SEAL KIT		

**IF YOU HAVE ANY QUESTIONS REGARDING THE PROPER OPERATION OR MAINTENANCE OF THIS TOOL, CONSULT YOUR AREA SUPERVISOR, OR CONTACT RELIABLE EQUIPMENT AT 800-966-3530**

