

OPERATORS' GUIDE

REL-POC/PCC SERIES

6 TON LOW PRESSURE CRIMPING TOOLS

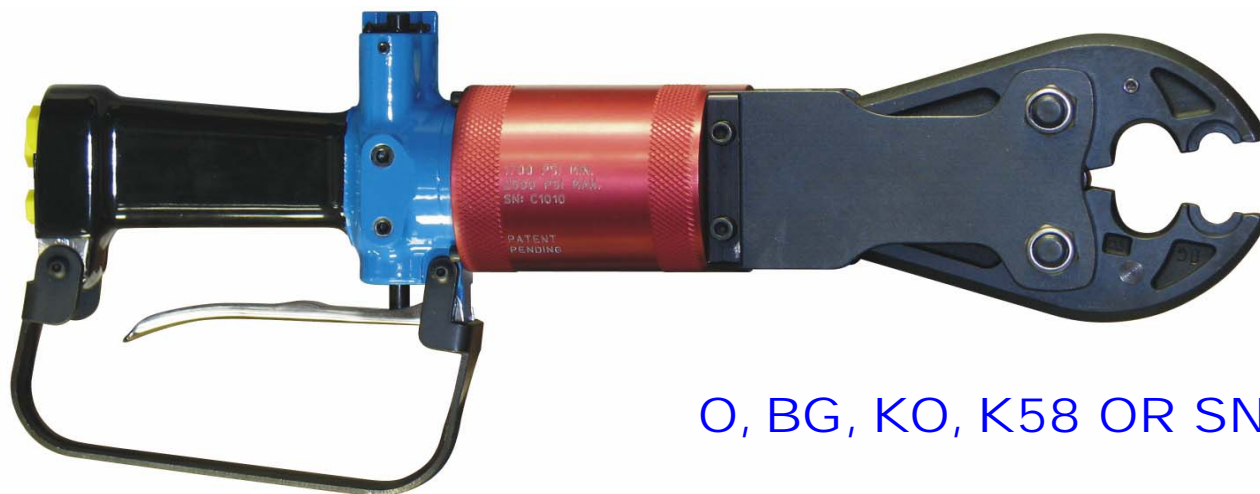

O, BG, KO, K58 OR SN



RELIABLE EQUIPMENT & SERVICE CO., INC.

92 Steamwhistle Drive • Ivyland, PA 18974 • USA
Phone: 215-357-3500 • Fax: 215-357-9193

MODEL: _____

MAX. PRESSURE: _____

SERIAL NO.: _____

YEAR: _____

WARNING



All information found in this guide must be read and understood before use or testing of this tool.

Failure to read and understand these warnings and safe handling instructions could result in severe personal injury and or death.



RELIABLE EQUIPMENT & SERVICE CO., INC.

REL-POC/PCC-____ Manual 03-10

DISTRIBUTED BY

REGISTRATION

UPON RECEIPT OF THIS TOOL, COMPLETE THE REGISTRATION BELOW.

COMPANY _____

ADDRESS _____

PHONE _____ FAX _____

SERIAL NUMBER _____

DATE OF PURCHASE _____

DEALER NAME _____



CAUTION

The information in this manual is intended to guide the user in the use and application of this tool. It is not intended as a substitute for proper training and experience in safe work practices for this type of equipment.

Consult your supervisor or safety personnel if you have any questions regarding the safe operation of this tool.

TABLE OF CONTENTS

DISTRIBUTOR INFORMATION	2
REGISTRATION	2
TABLE OF CONTENTS	3
TOOL SPECIFICATIONS	
REL-POC/PCC___ 6 ton Series	4
SAFETY INFORMATION AND WARNINGS	5-9
OPERATING INSTRUCTIONS	10
DIE INSTALLATION	11
DISCONNECTING HOSES	12
MAINTENANCE, INSPECTION & TESTING	13
GENERAL MAINTENANCE	14
JAW STYLE DIAGRAM.....	15
PARROT STYLE JAW ASSEMBLY	
DRAWING	16
PARTS LIST.....	17
MAINTENANCE RECORDS	18
CONTACT INFORMATION	18

If you have any questions regarding the information found in this manual please contact RELIABLE EQUIPMENT at 800-966-3530 or FAX 215-357-9193.



THIS SYMBOL INDICATES ITEMS OF EXTREME IMPORTANCE.

Safety of user and others may be in jeopardy if these instructions are not read and understood.

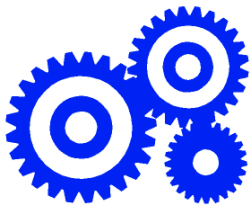

RELIABLE EQUIPMENT & SERVICE CO., INC.

REL-POC/PCC SERIES

6 TON LOW PRESSURE CRIMPING TOOLS



O, BG, KO, K58 OR SN



Fixed O or BG Nose with D3 Die Seat Accepts R6 & W Style Dies



Fixed O or 5/8 Nose Accepts Kearney Dies



D3 Die Seat Accepts R6 & W Style Dies

REL-POC/PCC__ Series

6 TON, LOW PRESSURE, HYDRAULIC CRIMPING TOOL

Operate from any 1,500-2,500 psi hydraulic power source. NO H/P intensifier needed.

Smaller than many equivalent 6 ton low pressure crimping tools currently available.

Crimp up to 4/O Copper or Aluminum.

Operate on Open- or Closed- Center systems.

Crimping head swivels 180° on handle.

D3 seat accepts R6 and "W" style dies.

"K" models accept Kearney style dies.

SPECIFICATIONS

System	Open/Closed Center
Force	12,000 lb.
Pressure	1,500-2,500 psi
Flow	3-9 gpm
Capacity	4/O Copper and Aluminum

* Dies not included.



RELIABLE EQUIPMENT & SERVICE CO., INC.

92 Steamwhistle Drive • Ivyland, PA 18974
Phone: 800-966-3530 • Fax: 215-357-9193
Visit us on the web at www.Reliable-Equip.com



WARNING

BEFORE USING THIS TOOL, READ THE WARNINGS and the recommended practices described in this manual. Failure by the operator to read and fully understand these warnings will leave this person unqualified to use and operate this tool. Property damage, severe personal injury, and/or death could result by not following these warnings.

These warnings will appear in appropriate locations when they are pertinent to the particular subject being shown. Read each one carefully and follow them strictly.



Eye Protection

WARNING

Always wear eye protection to avoid injury from flying debris or hydraulic oil leaks. Failure to do so can result in serious personal injury.



Skin Irritation

WARNING

Hydraulic oil may cause irritation. Use care to prevent contact with skin. In case of accidental contact, wash affected area immediately



Hard Hat

WARNING

Always wear a hard hat to avoid injury from falling debris. Failure to do so can result in serious personal injury.



Foot Protection

WARNING

Always wear foot protection. Failure to do so can result in serious personal injury.



Hearing Protection

WARNING

Always wear hearing protection, to avoid hearing loss due to long term exposure to high noise levels.



Protective Gloves

WARNING

Always wear protective gloves Failure to do so can result in serious personal injury.



WARNING

CRIMP DANGER

This hydraulic crimping tool can crush and/or disable. **KEEP ALL PARTS OF THE BODY AWAY FROM MOVING PARTS. DO NOT lock the tool in the On Position.** In an emergency, serious damage or injury could occur during the time required to stop the tool.
Failure to observe this warning could result in serious injury



WARNING

SERIOUS BURN HAZARD

HOT SURFACES MAY CAUSE SERIOUS BURNS.
The hydraulic cylinder may be hot during and after operation. **CAUTION: HYDRAULIC FLUID MAY CAUSE SERIOUS BURNS.**
Never disconnect tool, hoses, or fittings while the hydraulic power source is running or if the hydraulic fluid is hot.
Failure to observe this warning could result in serious injury.



WARNING

FIRE HAZARD

An incomplete crimp may pose a fire hazard.
Always use the appropriate connector, die set, and compression tool, as required by the intended application.
When the pressure relief valve sounds, the crimp tool has reached maximum pressure, and the crimp is complete.
Compression tool should be tested on a regular schedule to ensure pressure relief valve activates at the proper pressure.
Failure to observe this warning could result in serious injury.



WARNING

TOOL HAZARD

DO NOT OPERATE TOOL WITHOUT DIES.
DO NOT EXCEED THE MAXIMUM HYDRAULIC FLOW, RELIEF PRESSURE, OR BACK PRESSURE.
Failure to observe warnings could result in tool damage or injury.



WARNING

SAFE OPERATION & CARE

USE THIS TOOL FOR ITS INTENDED PURPOSE ONLY
Any other use can result in personal injury or property damage.

INSPECT TOOL BEFORE USE. Replace any worn, damaged or missing parts. A damaged or improperly assembled tool may malfunction, injuring operator and/or nearby personnel.

INSPECT HYDRAULIC HOSES AND COUPLINGS before each use. Repair or replace if any cracking, leakage, wear or damage is found. Worn or damaged hoses may fail resulting in personal injury or property damage.

CLEAR WORK AREA of all bystanders and unnecessary personnel before operating this tool.

KEEP ALL PARTS OF THE BODY AWAY FROM MOVING PARTS.

Failure to observe this warning could result in serious injury.



WARNING

HYDRAULIC POWER SUPPLY

DO NOT attempt to make any changes to any of the component parts or accessories when connected to the power source.

DO NOT adjust, inspect, or clean tool while the tool is connected to the power source. The tool could accidentally start up and cause serious injury.

DO NOT lock the tool in the On Position. In an emergency, serious damage or injury could occur during the time required to stop the tool.



WARNING

OIL INJECTION INJURY

Hydraulic oil or fluid under the skin is a serious injury. Oil under pressure can penetrate the skin and may cause dismemberment or loss of life. Seek medical assistance immediately if such an injury should occur.

Always wear safety gloves, eye protection and all required safety equipment when operating or handling this tool.

DO NOT use fingers or hands to attempt to locate a leak.

DO NOT handle hoses or couplers while system is pressurized.

NEVER open or service the system before depressurizing.



WARNING

HOSES AND FITTINGS

There exists the potential for shock in using anything other than certified nonconductive hoses and hydraulic oil with dielectric properties, when using system components near energized electrical lines. Failure to recognize these conditions could cause electrocution.

Hoses and fittings used with this tool must comply with S.A.E. J1273 which covers recommended practice for selection, installation, and maintenance of hose and hose assemblies. The **correct hoses and fittings are available from your supplier.**

WARNING: Failure to comply with these warnings could result in severe bodily injury.



WARNING

UNIT/HOSE CONNECTIONS

ALWAYS DISCONNECT pump/power source and move toggle switch to **OFF** before connecting or disconnecting any components.

ALWAYS DEPRESSURIZE hydraulic system, before slowly disconnecting this unit or any of the systems components.

ALWAYS TIGHTEN couplings completely. Loose or improperly tightened couplings will not allow fluid to pass through the hose creating a blockage in the supply or return line.

ALWAYS INSPECT HOSES AND CONNECTORS before connection to tool. Replace or repair if any signs of wear, damage, or leakage are evident. Leakage is a sign of deterioration in component parts. Worn or leaking parts must be repaired or replaced, or tool damage and/or severe injury could result.



CAUTION

HOSE INSTALLATION

ALWAYS ENSURE CONNECTORS ARE CLEAN

Care must be taken to assure the correct connection of the hoses to the pressure and return (tank) ports.

Connect the return hose to the return (tank) port on the power source, then to the return port on the tool.

Connect the pressure hose to the pressure port on the tool, then to the "P" pressure port on the power source.

Operation with hydraulic flow reversed can cause malfunction. Failure to fully comply can result in severe injury or death.



WARNING

Operation/Safety methods may vary in accordance with the working guidelines established by each utility or contractor.

For your own safety, ensure that you fully comply with all safe operation guidelines required by your employer.



WARNING

ELECTRICAL SHOCK HAZARD

Always wear and use the necessary clothing, equipment and safety practices to protect against electrical shock. Failure to follow these rules can result in serious personal injury or death.



GENERAL SAFETY



USE ALL APPROPRIATE AND APPLICABLE PERSONAL SAFETY EQUIPMENT as required by the operating company.

INSPECT TOOL BEFORE USE. Replace any worn, damaged or missing parts. A damaged or improperly assembled tool may injure operator and/or nearby personnel.

KEEP ALL PARTS OF THE BODY AWAY from moving parts of the tool.

KEEP HANDS OUT FROM BETWEEN CRIMPING JAWS AT TOOL HEAD.

ALL BODY PARTS SHOULD BE OUTSIDE DANGER ZONE PRIOR TO CRIMPING.

MAKE SURE there is no person in close proximity to you or the tool who could be injured by any operation being performed, tool malfunction or flying debris.

DO NOT OVEREXTEND your position by overreaching or unbalancing the footing necessary to maintain physical control of your body and the tool.

ALWAYS MAINTAIN a firm grip on the tool to avoid loss of control during an operation, causing property damage, serious injury or death.

USE THIS TOOL FOR THE MANUFACTURERS' INTENDED PURPOSE ONLY.

OBSERVE CLOSELY ALL SAFETY RULES FOR A PARTICULAR JOB CLASS

FAILURE TO HEED THESE WARNINGS COULD RESULT IN PROPERTY DAMAGE, SERIOUS PERSONAL INJURY OR DEATH.

OPERATION

Read entire manual prior to using this tool.

(Refer to all safety recommendations and warnings)

Observe all safety precautions and procedures required by the operating company.
(Also refer to SAFETY information found on pages 6 through 10)

This tool is factory set for operation on a Open-Center or Closed-Center hydraulic system.

The POC indicates that the tool should be used on an Open-Center System.

The PCC indicates that the tool should be used on a Closed-Center System.

1. The person operating the tool must know the type of hydraulic system on which the tool is being used.
2. The Spool Button (opposite handle) is marked OC or CC

Compress trigger partially for slow advance.

Compress trigger completely for fast advance.

NOTE: Jaw may be released as needed at any point in the crimp cycle.

Continue cycle until pressure has been achieved. Crimp is complete.

Ram will retract automatically when trigger is released.

Repeat steps above as specified by connector manufacturer.

NOTE: To reduce heat and wear on tool components, stop the power source, when the tool is not in use.

Manufacturer recommends regular testing for proper pressure and operation.

Test at least every 6 months, test more often under heavy usage.

**IF YOU HAVE ANY QUESTIONS REGARDING THE PROPER USE
AND/OR OPERATION OF THIS TOOL, CONSULT YOUR AREA SUPERVISOR,
OR CONTACT RELIABLE EQUIPMENT AT 800-966-3530**

DIE INSTALLATION

Observe safety precautions and procedures required by the operating company.

Turn flow control lever to the OFF position.

Turn hydraulic power source OFF.

Ensure crimp is within the capacity for the tool.

Refer to connector manufacturer's instructions for cable preparation and crimping procedure.

Ensure that you are using the proper die, as recommended by the connector manufacturer.

REL-POC/PCC-O, BG, or SN INSERT "W" STYLE DIE INTO DIE RETAINER

Open tool jaw completely.

Push down on die retainer pin. (Illustration A)

Slide die half into die seat and on the die pin.

Release retainer pin.

Check to ensure die is securely seated.

Repeat steps above for opposing die half.

REL-POC/PCC-KO, or K58 INSERT KEARNEY STYLE DIE INTO JAW

Open tool jaw completely.

Slide the die into die seat. (Illustration B)

Ball detent will snap into position.

Check to ensure die is securely seated.

Repeat steps above for opposing die half.

INSERT "W" STYLE DIE WITH D3 ADAPTER

Open tool jaw completely.

Slide the Kearney D3 die adapter into the jaw. (Illustration B) Ensure die is securely seated.

Push down on die retainer pin. (Illustration C)

Slide die half into die seat and on the die pin.

Release retainer pin.

Check to ensure die is securely seated.

Repeat steps above for opposing die half.



A. R6/W Style Die Installation

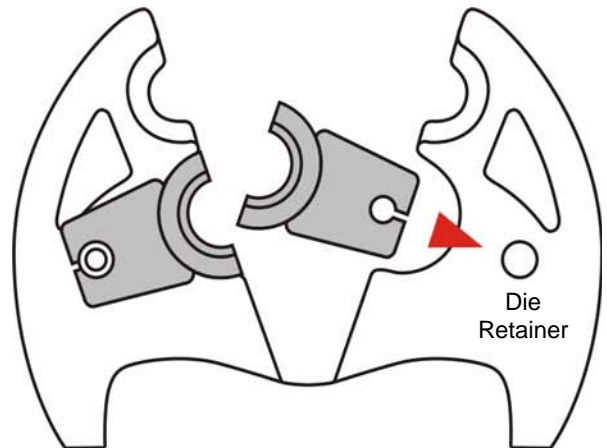

B. Kearney Style Die Installation

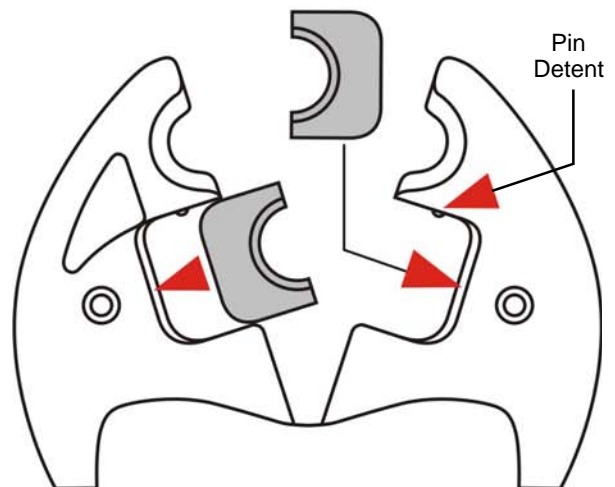

C. R6/W Die Installation with Kearney D3 Nest Die

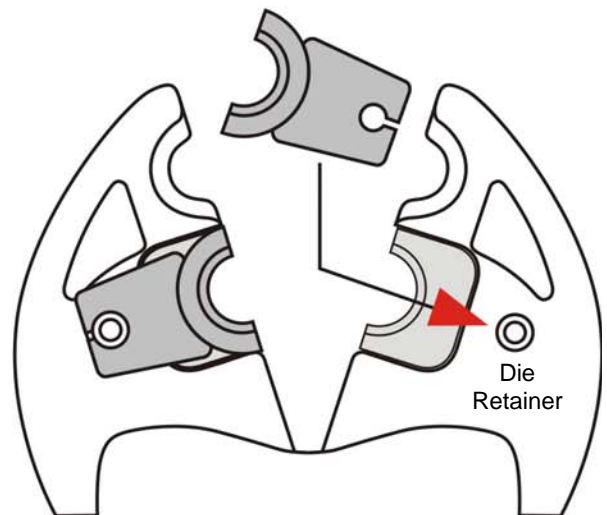



WARNING

SERIOUS BURN HAZARD

HOT SURFACES MAY CAUSE SERIOUS BURNS.

The hydraulic cylinder may be hot during and after operation.

CAUTION: HYDRAULIC FLUID MAY CAUSE SERIOUS BURNS.

Never disconnect tool, hoses, or fittings while the hydraulic power source is running or if the hydraulic fluid is hot.

Failure to observe this warning could result in serious injury.



CAUTION

DISCONNECTING HOSES

ALWAYS CAP HOSE & TOOL CONNECTORS WHEN NOT IN USE

Turn flow control lever to the **OFF** position.

Turn hydraulic power source **OFF**.

CAUTION: TOOL AND/OR HYDRAULIC FLUIDS MAY BE HOT.

CAUTION: TOOL/HOSES MAY STILL BE UNDER PRESSURE.

Follow the sequence below to prevent pressure buildup.

Loosen all connections slowly in case pressure has built up.

Disconnect the pressure hose from the power source.

Disconnect the pressure hose from the tool.

Disconnect the return/tank hose from the tool.

Disconnect the return/tank hose from the power source.

Failure to fully comply could result in severe injury or death.



WARNING

HOSE/CONNECTOR INSPECTION

ALWAYS DISCONNECT pump/power source and move toggle switch to **OFF** before connecting or disconnecting any components.

ALWAYS DEPRESSURIZE hydraulic system, before slowly disconnecting this unit or any of the systems components.

ALWAYS INSPECT HOSES AND CONNECTORS. Replace or repair if any leakage is evident. Leakage is a sign of deterioration in component parts. Worn or leaking parts must be repaired or replaced.

Loose or improperly tightened couplings will not allow fluid to pass through the hose creating a blockage in the supply or return line.

Failure to fully comply can result in severe injury or death.

DAILY MAINTENANCE

The life, reliability, and safety of the tool is dependent on proper maintenance. Clean all surfaces including head, die seat, ram, and body.

Install dust caps over the hydraulic ports when tool is disconnected.

Inspect tool, hoses, and couplers for leaks, cracks, wear, and damage.

Worn or damaged parts may malfunction during operation.

All parts must be replaced with new parts if signs of wear or damage are evident.

Keep Label Set clean and legible. Replace decals when necessary.



WARNING

BEFORE USING THIS PRODUCT READ THE SAFETY WARNINGS and recommended practices described in the manual. Failure by the operator to read and fully understand the warnings will leave this person unqualified to use and operate the tool.

Failure to observe all warnings and instructions could result in property damage, severe personal injury, and/or death.



CAUTION

Operation and safety methods may vary in accordance with the guidelines established by each utility. For your safety, ensure that you fully comply with all safe operation guidelines established by your respective power utility.

REL-SM

DANGER

 The user should be properly trained in the correct procedures required for work on or around electrical lines.

CAUTION

Do not operate without dies.

MONTHLY

Perform a thorough inspection of the hydraulic hoses and fittings as described in Publication SAE J1273 Hose and Hose Assemblies.

Apply a light oil to all moving parts.

QUARTERLY OR EVERY 500 CRIMPS

Perform a Pressure Relief Valve Check, to ensure proper pressure/activation of the pressure relief valve.

Test the crimping tool with 6 ton Test Slugs and Gauge, or Reliable 6 ton Load Cell. Consult your Reliable Equipment representative for test accessories.

ANNUALLY

If required by the regulations of your employer, organization, or safety committee guidelines, send the crimping tool to an Authorized Reliable Service Center for testing and evaluation.



WARNING

Inspection & Testing requirements may vary in accordance with the working guidelines established by each utility or contractor. For your own safety, ensure that you fully comply with all safe operation guidelines required by your employer.

GENERAL MAINTENANCE

NOTE: If your crimping tool requires adjustment or service, it is recommended that you send your tool to Reliable Equipment, for factory authorized service and testing.

Complete disassembly is not recommended. Return the unit to an authorized dealer for total disassembly and/or repair.

All maintenance or disassembly should take place on a flat, clean work surface covered with towels or wipers so as to have a clean space for the disassembled parts.

Inspect each part during disassembly for wear, scratches, and cuts. Discard the worn or damaged parts and replace with new factory authorized parts. *See parts drawings on pg16-20.*

O-rings are sensitive to sharp edges. Inspect closely for cuts or damage. A small cut will cause a leak. When assembling or disassembling O-rings, use hydraulic fluid as a lubricant to help disassembly or installation.

When disposing of hydraulic parts or components observe all federal, state, and local guidelines.

**IF YOU HAVE QUESTIONS REGARDING THE REPAIR AND MAINTENANCE
OF THIS TOOL CONTACT RELIABLE EQUIPMENT AT 800-966-3530**

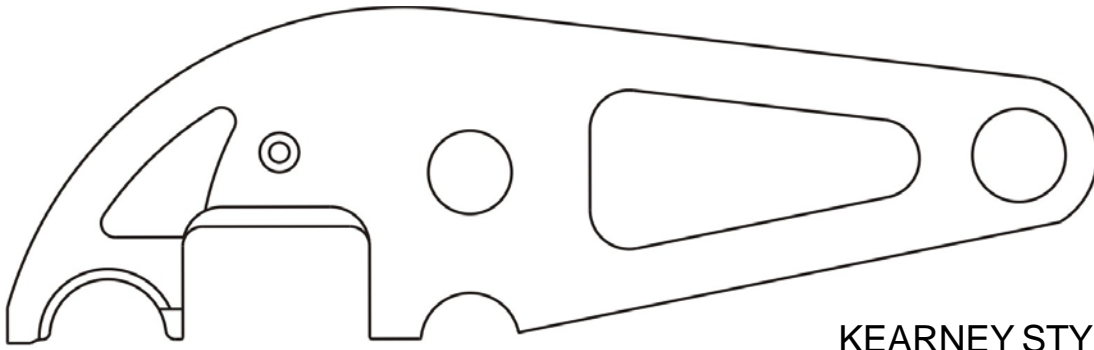

KEARNEY STYLE JAW
WITH O OR 58 FIXED NOSE DIE
D3 die adapter available

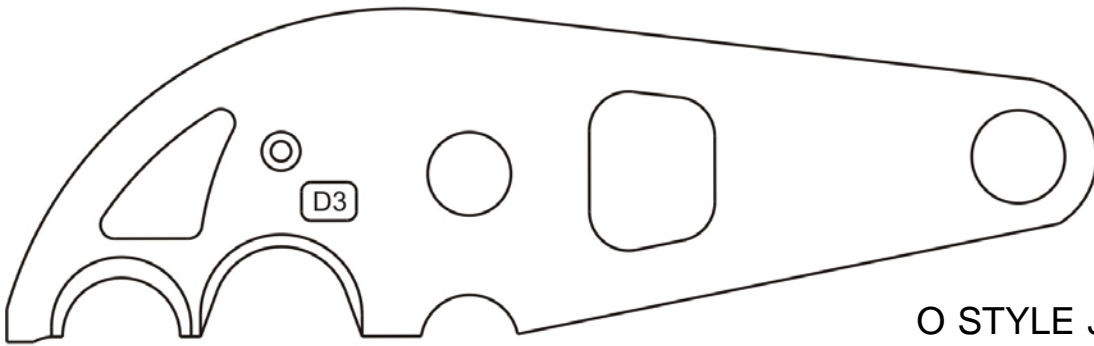

O STYLE JAW
WITH FIXED D3 SEAT

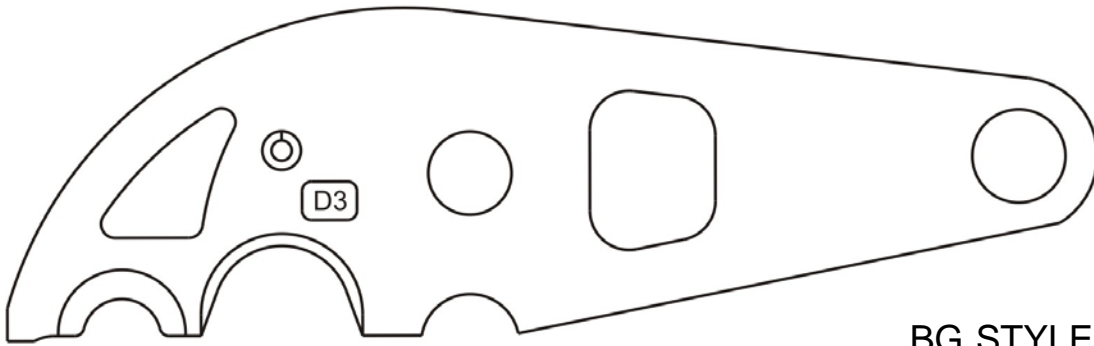

BG STYLE JAW
WITH FIXED D3 SEAT

ACCESS
CONFINED
SPACES

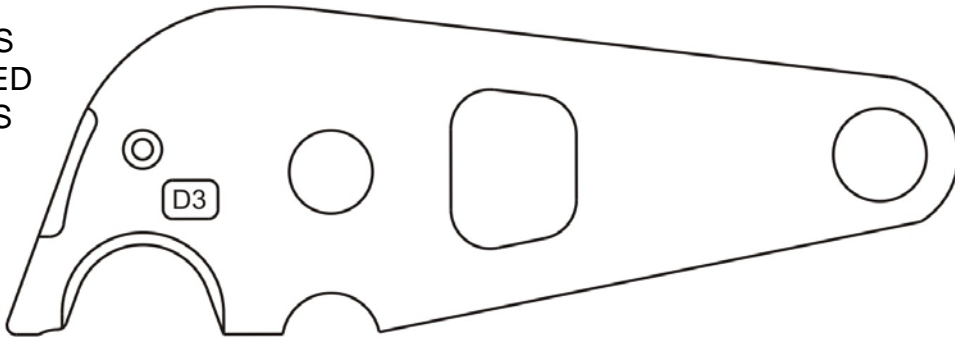

SNUB NOSE JAW WITH D3 SEAT

PARROT STYLE JAW ASSEMBLY

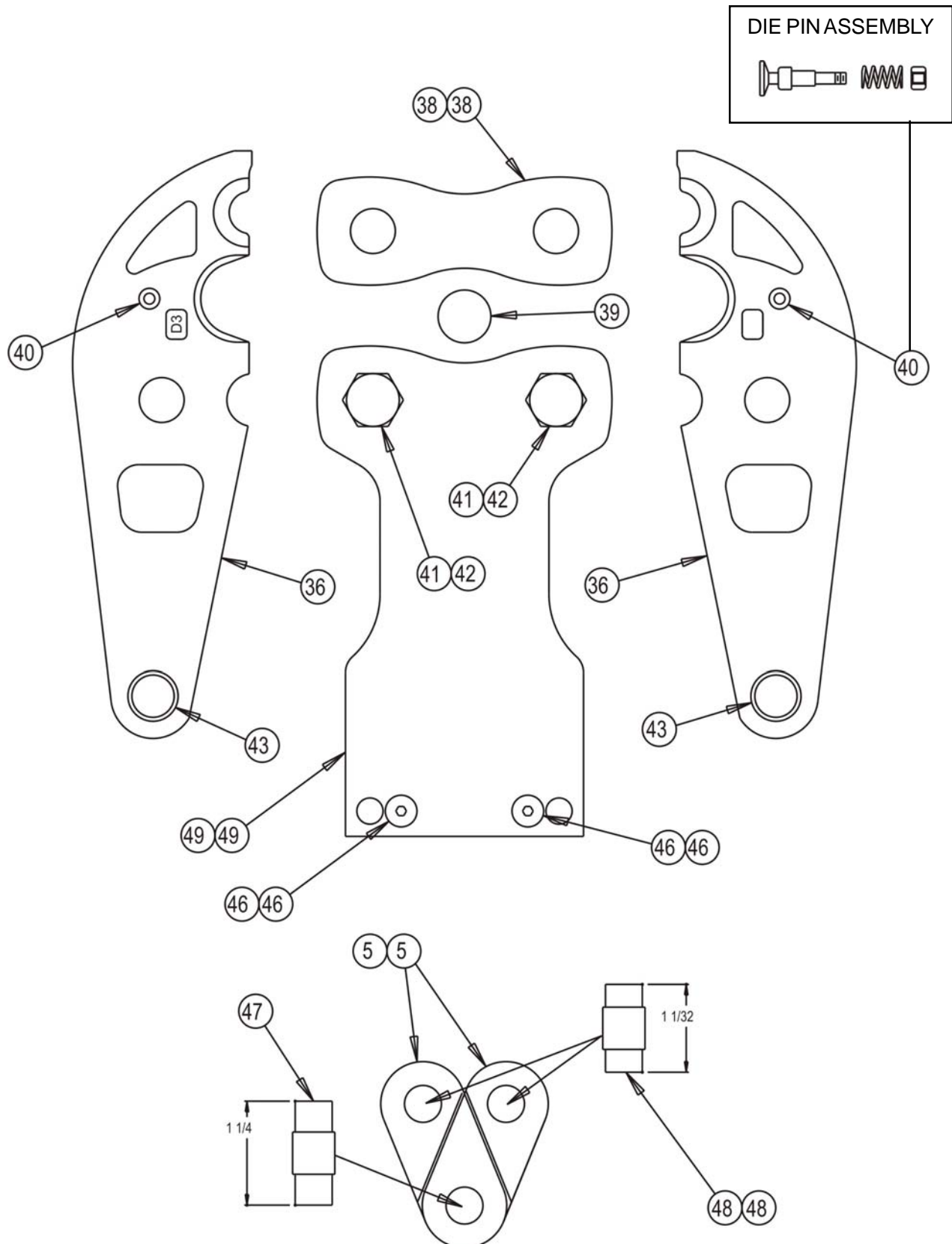

PARROT STYLE JAW ASSEMBLY

ITEM	PART	QTY	DESCRIPTION
5	14005	4	LINK
36	12847	2	CRIMPHEAD, BG
	12848	2	CRIMP HEAD, O
	12890	2	CRIMP HEAD, SNUB
	12891	2	CRIMP HEAD, KEARNY
38	12852	2	BOWTIE
39	12853	1	PIVOT PIN
40	K2854	2	DIE RELEASE PIN ASSEMBLY
41	14008	2	FRAME BOLT
42	12861	2	NUT, (FRAME BOLT)
43	12866	3	BUSHING
46	14009	4	SCREW, BUTTON HEAD
47	14012	1	DRIVE PIN
48	14013	2	LINK NPIN
49	13204	2	FRAME
	32351	1	SEAL KIT

* Indicates items included in Seal Kit. (kit includes items from pages 16-20)

