

# OPERATORS' GUIDE

## REL-TMP HYDRAULIC TAMPERS

Reliable's **REL-TMP** Series makes quick work of setting poles, asphalt patch and general construction backfill compacting.

### WARNING



All information found in this guide must be read and understood before use or testing of this tool.

Failure to read and understand these warnings and safe handling instructions could result in severe personal injury and or death.

### NOTICE

Sizes, weights and tool specifications listed in this manual are subject to change without notice. Please consult factory for information and updates.



REL TMP 60V  
Valve on Hose

REL TMP 72  
Valve on Tube

REL TMP 60  
Hose on Tube

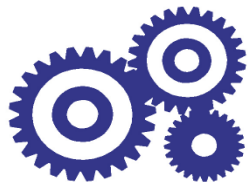

# RELIABLE EQUIPMENT & SERVICE CO., INC.

# TABLE OF CONTENTS

Registration .....	2	PARTS DIAGRAMS AND LISTS	
Description .....	3	REL TMP 72 .....	12-13
General Safety .....	4-6	REL TMP 60 .....	14-15
<b>SPECIFICATIONS</b>		REL TMP 60V .....	16-17
General .....	7	<b>TROUBLE SHOOTING</b>	
Connections and Hoses .....	8	Descriptions .....	18
Pre-Operation .....	9	Disassembly .....	19
Spool Selector .....	9	Maintenance Record .....	19
Tamper Operation .....	10	Contact Information .....	20
Disconnect Hoses .....	10		
<b>MAINTENANCE</b>			
General .....	11		
Safety Labels .....	11		
Hydraulic Fluid .....	11		

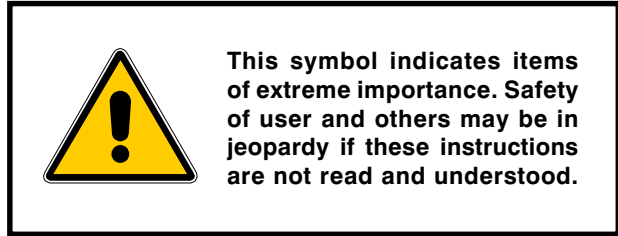

---

## REGISTRATION

UPON RECEIPT OF THIS TOOL, COMPLETE THE REGISTRATION BELOW.

COMPANY \_\_\_\_\_

ADDRESS \_\_\_\_\_  
\_\_\_\_\_

PHONE \_\_\_\_\_ FAX \_\_\_\_\_

SERIAL NUMBER \_\_\_\_\_

DATE OF PURCHASE \_\_\_\_\_

DEALER NAME \_\_\_\_\_

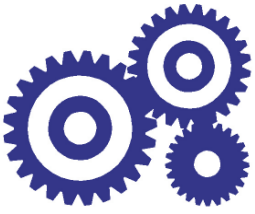

# RELIABLE EQUIPMENT & SERVICE CO., INC.

## REL-TMP

### HYDRAULIC POLE TAMPERERS

Reliable's **REL-TMP** Series will make quick work of setting poles, asphalt patch and general construction backfill compacting. Only 3 moving parts for low maintenance. Reversible On/Off valve for Open- and Closed-Center systems (hose-end models). Standard with kidney-shaped foot. Rotate trigger selector for Open and Closed Center systems (valve on tube models).

### TAMPER - OPTIONS

- REL TMP 72 72" Tamper Valve on Tube
- REL TMP 60 60" Tamper Direct Coupled
- REL TMP 60V 60" Tamper Direct Coupled

### SPECIFICATIONS

- Width: 4"
- Flow Range: 4-6 gpm
- Pressure: 1,000-2,000 psi
- Pressure Port Thread: 9/16-18 SAE O-Ring
- Return Port Thread: 3/4-16 SAE O-Ring
- Standard Foot Size: 2.5 x 8" kidney-shaped
- Blows Per Minute: 1,160 @ 5 gpm

Consult your **RELIABLE** representative for more information about our complete line of hydraulic tools.



Shown with Kidney Shaped Pole Foot

### RELIABLE EQUIPMENT & SERVICE CO., INC.

92 Steamwhistle Drive • Ivyland, PA 18974  
Phone: 800-966-3530 • Fax: 215-357-9193  
Visit us on the web at [www.Reliable-Equip.com](http://www.Reliable-Equip.com)



**WARNING**

BEFORE USING THIS TOOL, READ THE WARNINGS and the recommended practices described in this manual. Failure by the operator to read and fully understand these warnings will leave this person unqualified to use and operate this tool. Property damage, severe personal injury, and/or death could result by not following these warnings.

These warnings will appear in appropriate locations when they are pertinent to the particular subject being shown. Read each one carefully and follow them strictly.



**Eye Protection**

**WARNING**

Always wear eye protection to avoid injury from flying debris or hydraulic oil leaks. Failure to do so can result in serious personal injury.



**Dust Mask**

**WARNING**

Always wear a dust mask. Failure to observe this warning may result in serious health issues and/or breathing difficulty.



**Hard Hat**

**WARNING**

Always wear a hard hat to avoid injury from falling debris. Failure to do so can result in serious personal injury.



**Foot Protection**

**WARNING**

Always wear foot protection. Failure to do so can result in serious personal injury.



**Hearing Protection**

**WARNING**

Always wear hearing protection, to avoid hearing loss due to long term exposure to high noise levels.



**Operation/Safety** methods may vary in accordance with the working guidelines established by each utility or contractor.

**WARNING**

For your own safety, ensure that you fully comply with all safe operation guidelines required by your employer.



**WARNING**

## Safe Operation & Care

**USE THIS TOOL FOR ITS INTENDED PURPOSE ONLY**

Any other use can result in injury or property damage.

**INSPECT TOOL BEFORE USE.** Replace any worn, damaged or missing parts. A damaged or improperly assembled tool may malfunction, injuring operator and/or nearby personnel.

**INSPECT HYDRAULIC HOSES AND COUPLINGS** before each use.

Repair or replace if any cracking, leakage, wear or damage is found. Worn or damaged hoses may fail resulting in personal injury or property damage.

**CLEAR WORK AREA** of all bystanders and unnecessary personnel before operating this tool.

**KEEP ALL PARTS OF THE BODY AWAY FROM MOVING PARTS.**

Failure to observe this warning could result in serious injury.



**WARNING**

## Safety

**DO NOT** attempt to make any changes to any of the component parts or accessories when connected to the power source.

**DO NOT** adjust, inspect, or clean tool while the tool is connected to the power source. The tool could accidentally start up and cause serious injury.

**DO NOT** lock the tool in the On Position. In an emergency, serious damage or injury could occur during the time required to stop the tool.



**WARNING**

## Oil Injection Injury

Hydraulic oil or fluid under the skin is a serious injury. Oil under pressure can penetrate the skin and may cause dismemberment or loss of life. Seek medical assistance immediately if such an injury should occur.

Always wear safety gloves, eye protection and all required safety equipment when operating or handling this tool.

**DO NOT** use fingers or hands to attempt to locate a leak.

**DO NOT** handle hoses or couplers while system is pressurized.

**NEVER** open or service the system before depressurizing.



**WARNING**

## Burn Hazard

Do Not connect or disconnect tool, hoses or fittings while power source is running or while hydraulic fluid is hot. Hot hydraulic fluid may cause serious burns.

Failure to observe this warning could result in serious injury.



**WARNING**

## Electrical Shock Hazard

Use only certified nonconductive hoses and fittings. Always wear and use the necessary clothing, equipment and safety practices to protect against electrical shock. Failure to follow these rules can result in serious personal injury or death.



**CAUTION**

## Vibration Hazard

Apply just enough pressure to control the tool operation. Applying excess pressure to the tool may cause operator discomfort or temporary numbness.

Failure to observe this warning could result in serious injury.



**CAUTION**

## Safe Handling

HYDRAULIC FLUID MAY CAUSE SKIN IRRITATION.

Prevent hydraulic fluid from making contact with skin.

IN THE EVENT OF SKIN CONTACT immediately wash thoroughly.

Failure to observe this warning could result in injury.



**CAUTION**

## General Safety

Ensure that all fellow employees and bystanders are clear and protected from possible injury caused by this tool or the operations being performed. Persons in close proximity could be injured and property damaged if the tool were to malfunction.

This tool should always be used within the limits and purposes stated by the product manufacturer. Abuse or usage beyond the manufacturers' intended purposes could cause damage to the tool and severe injury to the operator.

# TOOL SPECIFICATIONS

Overall Length (W/O HOSES) .....	72 in.	REL TMP 72
.....	60 in.	REL TMP 60
.....	60 in.	REL TMP 60
Width .....	4 in.	
Standard Foot Size .....	2.5 x 8"	Kidney Type
Weight .....	22 lbs.	REL TMP 72
.....	20 lbs.	REL TMP 60

## HYDRAULIC POWER SOURCE SPECIFICATIONS

The following requirements are essential for the safe operation of this tool.

Hydraulic System .....	Open- or Closed- Center	
Flow Range .....	4 gpm	Minimum
.....	5 gpm	Optimum
.....	6 gpm	Maximum
Operating Pressure .....	1,000 - 2,000 psi	
Relief Setting .....	2,000 psi	
Filtration .....	10 Micron	Nominal
Back Pressure .....	200 psi	Maximum *
Blows Per Minute .....	980 bpm	@ 4 gpm
.....	1,160 bpm	@ 5 gpm
.....	1,300 bpm	@ 6 gpm
Pressure Port Thread .....	9/16-18 Female	SAE O-Ring
Return Port Thread .....	3/4-16 Female	SAE O-Ring

\* 200 psi (1,379 kPa) is the maximum agreed standard for the HTMA (Hydraulic Tool Manufacturers Association).



### WARNING

These specifications must be strictly adhered to for the safe and effective operation of this tool.

**HYDRAULIC FLOW MUST NOT EXCEED 6 GPM**

**LIMIT RELIEF SETTINGS TO 2,000 PSI** (13,790 kPa)

Any deviation can result in severe injury or death to the operator and or extraneous personnel.



**WARNING**

## HOSES AND FITTINGS

There exists the potential for shock in using anything other than certified nonconductive hoses and hydraulic oil with dielectric properties, when using system components near energized electrical lines. Failure to recognize these conditions could cause electrocution.

Hoses and fittings used with this tool must comply with S.A.E. J1273 which covers recommended practice for selection, installation, and maintenance of hose and hose assemblies. The **correct hoses and fittings are available from your supplier.**

**WARNING:** Failure to comply with these warnings could result in severe bodily injury.



**WARNING**

## UNIT/HOSE CONNECTIONS

**ALWAYS SHUT OFF** pump/power source and move flow selector to **OFF** before connecting or disconnecting system components.

**ALWAYS DEPRESSURIZE** hydraulic system before slowly disconnecting this unit or any of the systems components.

**ALWAYS TIGHTEN** couplings completely. Loose or improperly tightened couplings will not allow fluid to pass through the hose creating a blockage in the supply or return line.

**ALWAYS INSPECT HOSES AND CONNECTORS** before connection to tool. Replace or repair if any leakage is evident. Leakage is a sign of deterioration in component parts. Worn or leaking parts must be repaired or replaced, or tool damage or severe injury could result.



**CAUTION**

## HOSE INSTALLATION

Care must be taken to assure the correct connection of the hoses to the pressure “P” and return “T” ports.

Connect the return hose to the return port on the power source, then to the return “T” port on the tool.

Connect the pressure hose to the pressure port “P” on the tool, then to the pressure port on the power source.

Operation with hydraulic flow reversed can cause malfunction. Failure to fully comply can result in severe injury or death.

# PRE-OPERATION OF TOOL



**WARNING**

**DO NOT** connect hoses or fittings to this tamper before completing all of the instructions in this section.

Ensure power source is **OFF**, and hydraulic flow is lever is turned **OFF**.

Failure to comply with this warning can result in severe injury or death.

Before attempting to run or use the Tamper, check all connections, including hoses, and couplings. Ensure that valve is moving freely.

Wear all safety items required and make sure that the working area is clear of obstructions and non essential personnel. Set the Tamper to Open- or Closed-Center, according to which system the power supply pump provides. It is important to know which type of power system is supplying the tool so that the tamper can be properly set. All these items are crucial to the safe operating procedure of the tamper.

## Tool Set-up for Open-Center or Closed-Center Systems

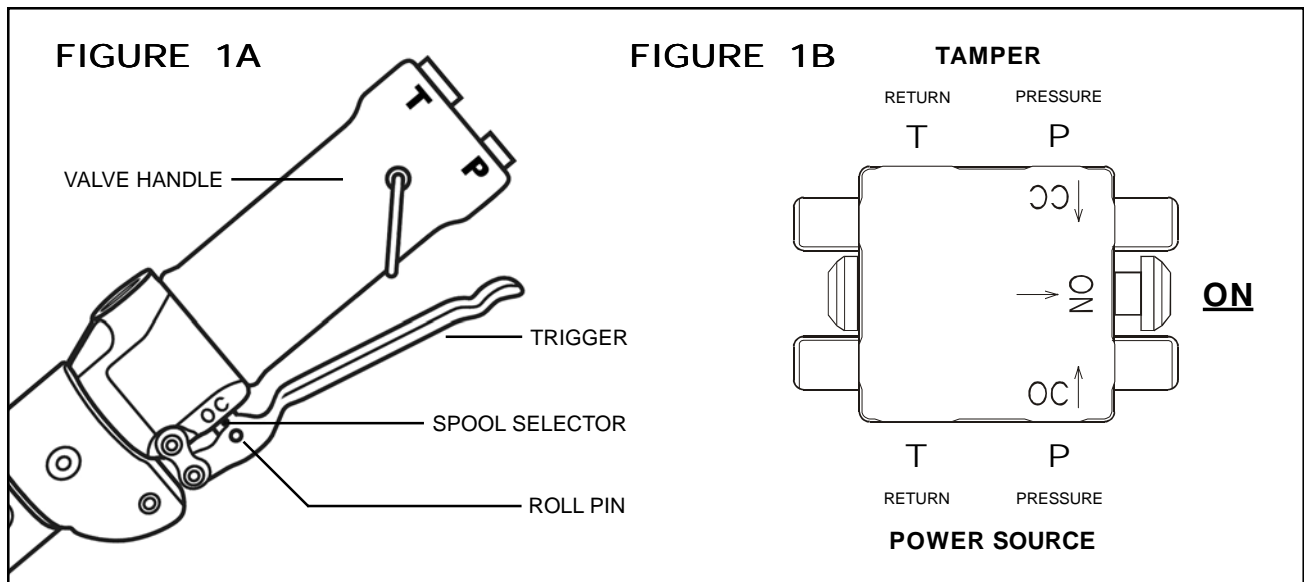

**Model REL TMP 72:** Refer to the illustration in **Figure 1A** above.

Remove the roll pin which connects the trigger to the spool selector.

To select Open-Center operation rotate the spool selector so that the 1/8" diameter gold indentation is aligned with letters "OC" stamped into the valve handle.

To select Closed-Center operation rotate the spool selector so that the 1/8" diameter gold indentation is aligned with letters "CC" stamped into the valve handle.

**Model REL TMP 60V:** Refer to the illustration in **Figure 1B** above.

This model is factory configured for Open-Center operation. (as shown above)

Connect pressure and return from power source to OC ports on valve as shown above.

### Valve Conversion for Closed-Center Operation:

Rotate the valve 180°. Connect return and pressure hoses from tamper to OC ports on valve.

Connect return and pressure from power source to the CC ports on valve as shown above.

# TAMPER OPERATION

There are a number of safety items that need to be addressed when using the tool. Seek out the supervisor for basic instruction in handling the tool. Some basic problems are easily overcome by knowing the rules of operation.

Inspect, set-up and connect the tool as described on the previous pages.

Start the hydraulic power source.

Allow the power source to run for a few minutes to warm the hydraulic fluid.

Set the tamper foot onto the material to be compacted.

Firmly grasp the tube with both hands. Ensure proper footing and balance.

Activate control valve or control spool to the **ON** position. (as shown in figure 1B)

Apply light downward pressure to the tamper.



**WARNING:** Tamper operation does not require excessive pressure. Excess pressure may cause operator discomfort, fatigue or numbness.



**WARNING:** Operator must maintain a firm grip and proper balance, controlling the tool with both hands at all times. Failure to maintain control of the tool could result in severe injury or death.

When finishing with the tamping operation, release the control valve or move the control spool to the **OFF** position.

Move the flow lever on the power source to the **OFF** position.

Stop the hydraulic power source.



**WARNING:** DO NOT disconnect the tool, hoses, or fittings while the tool is running, hot, or under pressure. Serious injury or burns could result.

# DISCONNECT HOSES

Move the flow lever on the power source to the **OFF** position.

Stop the hydraulic power source.

Disconnect the pressure hose from the pressure “P” port on the power source, then disconnect the hose from the pressure port on the tool.

Disconnect the return hose from the return “T” port on the tool, then disconnect the hose from the return port on the power source.

Install dust caps on all connectors to prevent dirt and contaminants from entering the hydraulic system.

# MAINTENANCE

The life, reliability, and safety of the tool is dependent on proper maintenance.

## DAILY MAINTENANCE

**Clean** all surfaces including handle, trigger, valve, fittings, hoses and housing.

**Inspect** tool for wear and damage.

Worn or damaged parts can cause malfunction during operation.

Inspect for cracked hoses and leaking fittings.

**Check** fluid level of the power source reservoir frequently.

**All the above items must be replaced with new parts if signs of wear are evident.**

**FLUID CONTAMINATION:** Cover the ends of fittings with a dust cap when disconnected. This will help keep the fluid from contamination.

**MONTHLY MAINTENANCE:** Inspect per Appendix A, SAE Standard J1273, 5/86 for hose or fitting damage such as wear, cracks or leakage, replace the necessary parts.

**NOTE:** Keep Label Set clean and legible. Replace decals when necessary. Part #RL27400



**WARNING**

BEFORE USING THIS PRODUCT READ THE SAFETY WARNINGS and recommended practices described in the manual. Failure by the operator to read and fully understand the warnings will leave this person unqualified to use and operate the tool.

Failure to observe all warnings and instructions could result in property damage, severe personal injury, and/or death.



**WARNING**

**Tamper is Factory Configured for Open-Center Tool Systems. Convert for Closed-Center Use**

Rotate the valve 180°. Connect from tamper to OC ports on valve.

Connect return and pressure from power source to the CC ports on valve.

Failure to observe all warnings could result in property damage, severe injury, and/or death.



**CAUTION**

Operation and safety methods may vary in accordance with the guidelines established by each utility. For your safety, ensure that you fully comply with all safe operation guidelines established by your respective power utility.

REL-SM



**DANGER**

The user should be properly trained in the correct procedures required for work on or around electrical lines.

## HYDRAULIC FLUIDS

All hydraulic fluids that meet these listed specifications or the listed HTMA specifications may be used for this tool.

**S. U. S.**

@ 100° F (38° C) ..... 140 TO 225

@ 210° F (99° C) ..... 40 minimum

**FLASH POINT** ..... 340° F min. (170° C min.)

**POUR POINT** ..... -30° F min. (-34° C min.)



# REL TMP 72 - RELIABLE 72" TAMPER WITH VALVE ON TUBE

ITEM	DESCRIPTION	QTY	PART#
1	TAMPER BODY	1	R27001
2	RAM	1	R27002
3	PACKING NUT (w/o SEALS)	1	R27003
4 *	U-CUP SEAL	1	*
5 *	U-CUP SEAL	1	*
6 *	O-RING	1	*
7 *	RAM WIPER	1	*
8	DRIVER SHAFT	1	R27008
9	SHUTTLE SPOOL	1	R27009
10	VALVE BODY	1	R27010
11	PLUG	1	R27011
12	SPOOL STOP	1	R27012
13	COMPRESSION SPRING	1	R27013
14	PLUG	1	R27014
15 *	O-RING	2	*
16 *	O-RING	3	*
17 *	O-RING	1	*
18	CAP SCREW	8	R27018
19	LOCK WASHER	8	R27019
20	CAP SCREW	1	R27020
21	FOOT, KIDNEY SHAPED	1	R27021
22	FLAT WASHER	1	R27022
23	CAP SCREW	1	R27023
24	ADAPTER	2	R27024
25	TUBE	1	R27025
29	HOSE ASSEMBLY	2	R27029
30	ADAPTER	2	R27030
30A *	O-RING	2	*
31	GUARD, TWO PIECE (includes item #20)	1	R27031
32	CAP SCREW	2	R27032
33	DOUBLE WASHER	2	R27033
34	WASHER	2	R27034
35	CAP SCREW	2	R27035
36	NUT, COUNTERSINK	2	R27036
37	TRIGGER LEVER	1	R27037
38	LINK	2	R27038
39	CAP SCREW	2	R27039
40	NUT, HEX LOCKING	2	R27040
41	ROLL PIN	1	R27041
43	BRASS SLEEVE	1	R27043
44	TRIGGER LOCK	1	R27044
45	HANDLE, INSULATED	1	R27045
46	CONTROL SPOOL, (OPEN-CENTER / CLOSED-CENTER)	1	R27046
47	COMPRESSION SPRING	1	R27047
48	END CAP	1	R27048
49	WASHER	1	R27049
50	RETAINING RING	2	R27050
51 *	O-RING	1	*
52 *	O-RING	1	*

## REPAIR KITS

	PACKING GLAND ASSEMBLY (Includes Items 3-7)	1	R27003A
	VALVE ASSEMBLY (Includes Items 45-52)	1	R27090
*	SEAL KIT (* Items Included In Kit)	1	R27100



# REL TMP 60 - RELIABLE 60" TAMPER WITH WHIPS

ITEM	DESCRIPTION	QTY	PART#
1	TAMPER BODY	1	R27001
2	RAM	1	R27002
3	PACKING NUT (w/o SEALS)	1	R27003
4*	U-CUP SEAL	1	*
5*	U-CUP SEAL	1	*
6*	O-RING	1	*
7*	RAM WIPER	1	*
8	DRIVER SHAFT	1	R27008
9	SHUTTLE SPOOL	1	R27009
10	VALVE BODY	1	R27010
11	PLUG	1	R27011
12	SPOOL STOP	1	R27012
13	COMPRESSION SPRING	1	R27013
14	PLUG	1	R27014
15*	O-RING	2	*
16*	O-RING	3	*
17*	O-RING	1	*
18	CAP SCREW	8	R27018
19	LOCK WASHER	8	R27019
21	FOOT, KIDNEY SHAPED	1	R27021
22	FLAT WASHER	1	R27022
23	CAP SCREW	1	R27023
24	ADAPTER	2	R27024
25	TUBE	1	R27025
29	HOSE ASSEMBLY, INSIDE	1	R27029
30	HOSE ADAPTER WITH O-RING	4	R27030
30A*	O-RING	4	*
60	CLAMP, HOSE HALF	2	R27060
62	NYLON TIE	2	R27062
63	SCREW	4	R27063
64	STRAIN RELIEF	1	R27064
80	MANIFOLD	1	R27080
81	HOSE ASSEMBLY, OUTSIDE (w/o COUPLER)	2	R27081

## REPAIR KITS

*	PACKING GLAND ASSEMBLY (Includes Items 3-7)	1	R27003A
	SEAL KIT (* Items Included In Kit)	1	R27100

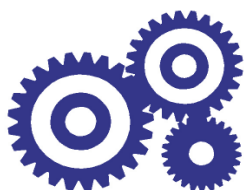

# RELIABLE EQUIPMENT & SERVICE CO., INC.

# REL TMP 60V - RELIABLE 60" TAMPER VALVE ON HOSE

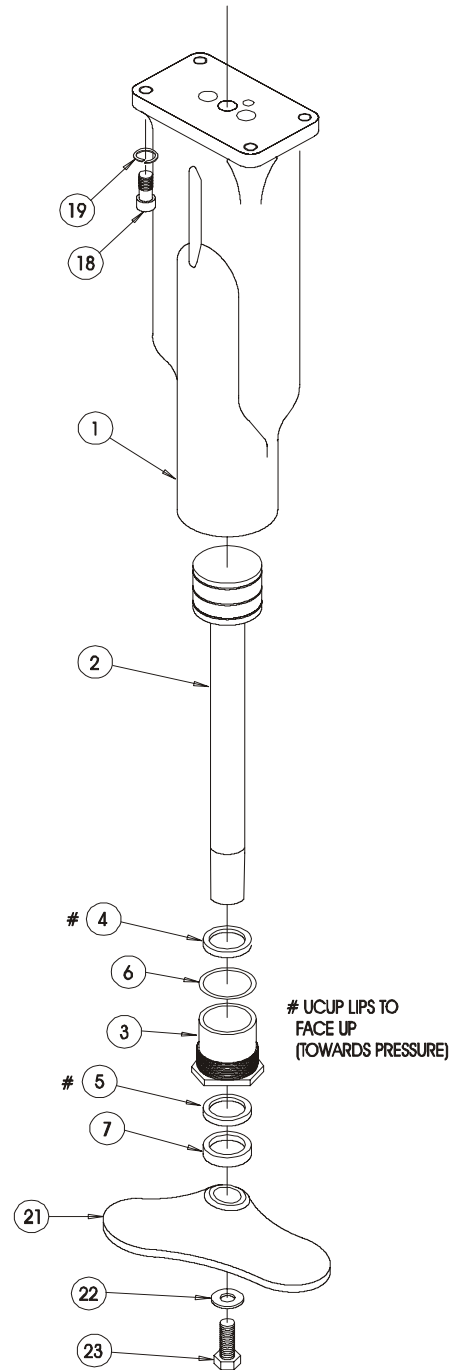
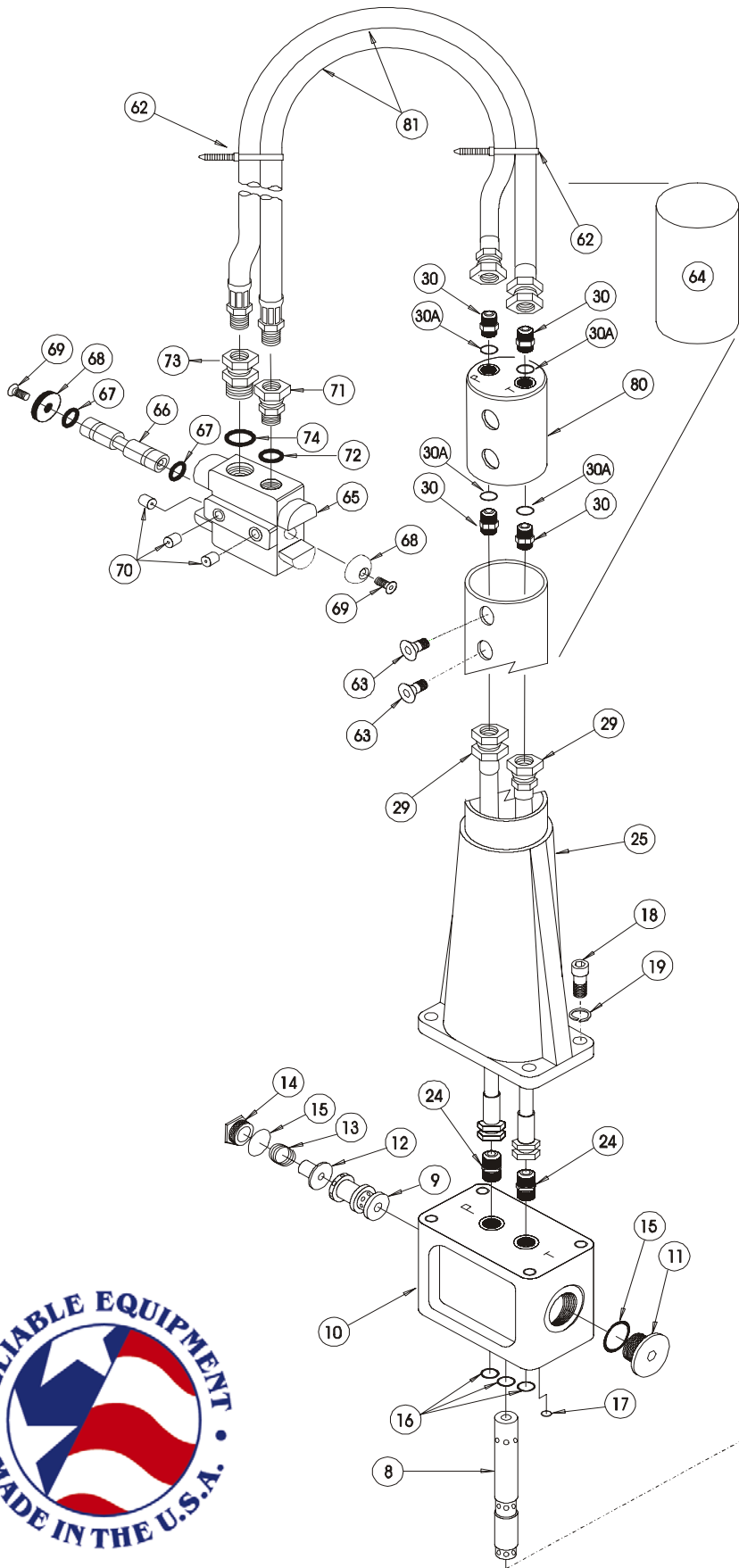

# REL TMP 60V - RELIABLE 60" TAMPER VALVE ON HOSE

ITEM	DESCRIPTION	QTY	PART#
1	TAMPER BODY	1	R27001
2	RAM	1	R27002
3	PACKING NUT (w/o SEALS)	1	R27003
4*	U-CUP SEAL	1	*
5*	U-CUP SEAL	1	*
6*	O-RING	1	*
7*	RAM WIPER	1	*
8	DRIVER SHAFT	1	R27008
9	SHUTTLE SPOOL	1	R27009
10	VALVE BODY	1	R27010
11	PLUG	1	R27011
12	SPOOL STOP	1	R27012
13	COMPRESSION SPRING	1	R27013
14	PLUG	1	R27014
15*	O-RING	2	*
16*	O-RING	3	*
17*	O-RING	1	*
18	CAP SCREW	8	R27018
19	LOCK WASHER	8	R27019
21	FOOT, KIDNEY SHAPED	1	R27021
22	FLAT WASHER	1	R27022
23	CAP SCREW	1	R27023
24	ADAPTER	2	R27024
25	TUBE	1	R27025
29	HOSE ASSEMBLY, INSIDE	1	R27029
30	HOSE ADAPTER WITH O-RING	4	R27030
30A*	O-RING	4	*
62	NYLON TIE	2	R27062
63	SCREW	4	R27063
64	STRAIN RELIEF	1	R27064
65	VALVE BODY	1	R27601
66	SPOOL	1	R27602
67	O-RING	2	R27052
68	BUTTON	2	13138
69	SCREW	2	13139
70	PIPE PLUG	3	12791
71	PRESSURE LINE ADAPTER	2	R27071
72	O-RING	1	R27030A
73	RETURN LINE ADAPTER (LARGE)	4	R27073
74	O-RING	1	R27074
80	MANIFOLD	1	R27080
81	HOSE ASSEMBLY, OUTSIDE (w/o COUPLER)	2	R27081

## REPAIR KITS

	PACKING GLAND ASSEMBLY (Includes Items 3-7)	1	R27003A
	CONTROL VALVE (Complete - Includes Items 65-70)	1	R27600
*	SEAL KIT (* Items Included In Kit)	1	R27100

# TROUBLE SHOOTING

**Determine the source** (i.e. tool or hydraulic system) **of the problem before trouble shooting.**

## Will not run

Ram is restricting hydraulic fluid .....	Tamp tool foot on ground to push flow of ram up
Improper power source .....	Verify power source meets specifications
Low hydraulic fluid .....	Check fluid level
Incorrect viscosity .....	Use recommended fluid
Tool damaged .....	Disassemble and replace damaged parts
Hoses incorrectly connected .....	Switch hoses ( <i>see hose connection in this manual</i> )
Dirt in tool .....	Disassemble, clean and repair

## Tool runs slow

Power supply not functioning correctly .....	Reset to operator manual specs.
Fluid not warmed to correct temp .....	Allow tool a warm-up period
Fluid viscosity too high .....	See recommended viscosity
Air in hydraulic system .....	Check hoses for breaks, leaks, or loose connections
Hydraulic fluid level low .....	Fill to level. Check for leaks
Tool components loose .....	Tighten component hardware
Worn or damaged components .....	Replace worn or damaged components

## Tool runs too fast

Power supply not functioning correctly .....	Reset to operator manual specs.
Excessive downward pressure .....	Do not apply downward pressure.

## Tool operation is erratic

Hydraulic fluid not warm .....	Allow oil to warm up
Dirt or contaminants in tool .....	Clean and reassemble
Air in system .....	Check hoses for breaks, leaks, or loose connections

## Tool runs continuously

Tool locked in "ON" position .....	Release trigger lever lock
------------------------------------	----------------------------

## Trigger operation is difficult

Tool valve spool dirty .....	Clean up spool so that spool slides freely
Check for misalignment .....	Align trigger linkage
Components worn or damaged .....	Replace damaged components

## Tool runs hot

Low fluid level .....	Fill pump reservoir to correct level
Fluid viscosity incorrect .....	Use recommended fluid
Fluid dirty .....	Drain tank, flush, and replace fluid
Power supply not functioning correctly .....	Reset to operator manual specs
Worn or damaged O-rings or gaskets .....	Replace worn or damaged components
Hydraulic fluid level low .....	Fill to level. Check for leaks

## Tool is erratic

Hydraulic fluid not warm .....	Allow oil to warm up
Dirt or contaminants in tool .....	Clean and reassemble
Air in system .....	Check hoses for breaks, leaks, or loose connections

## Tool leaks hydraulic fluid

Worn or damaged seals .....	Disassemble and replace worn or damaged seals
Components loose .....	Tighten component hardware

## Tool lacks power

Control valve leaking .....	Worn part or seal rings
-----------------------------	-------------------------

# READ BEFORE DISASSEMBLY



**WARNING**

## Safety

**DO NOT** attempt to make any changes to any of the component parts or accessories when connected to the power source.

**DO NOT** adjust, inspect, or clean tool while the tool is connected to the power source. The tool could accidentally start up and cause serious injury.



**WARNING**

Before disassembly, disconnect hoses as described in this manual. Any residual pressure within the unit can and will spray at high velocity, injuring the person doing the disassembly. Hot or pressurized hydraulic fluid will cause serious injury or death.

**Complete disassembly is not recommended.** Return the unit to an authorized dealer for total disassembly and/or repair.

All maintenance or disassembly should take place on a flat, clean work surface covered with towels or wipers so as to have a clean space for the disassembled parts.

Inspect each part during disassembly for wear, scratches, and cuts. Discard the worn or damaged parts and replace with new factory authorized parts.

O-rings are sensitive to sharp edges. Inspect closely for cuts or damage. A small cut will cause a leak. When assembling or disassembling O-rings, use hydraulic fluid as a lubricant to aid disassembly or installation.

## MAINTENANCE RECORD

Date	Parts or Service Required

If you have any questions regarding the information found in this manual please contact RELIABLE EQUIPMENT at the address, phone or fax numbers shown below.



92 Steamwhistle Drive • Ivyland, PA 18974  
Phone: 800-966-3530 • Fax: 215-357-9193  
Visit us on the web at [www.Reliable-Equip.com](http://www.Reliable-Equip.com)