

OPERATORS' GUIDE

REL-2000MC MANUAL HYDRAULIC 2" CUTTING TOOL



This guillotine-type cutter will make a straight, clean cut every time. These cutters can be used for cutting copper, aluminum, soft steel bolts, EHS, standard guy, ACSR, rebar, ground and anchor rod.

—WARNING—



All information found in this manual must be read and understood before use or testing of this tool.

Failure to read and understand these warnings and safe handling instructions could result in severe personal injury and or death.



RELIABLE EQUIPMENT & SERVICE CO., INC.

The information found in this manual is subject to change without notice. Please contact Reliable Equipment for the most current product information.

DISTRIBUTED BY

REGISTRATION

UPON RECEIPT OF THIS TOOL, COMPLETE THE REGISTRATION BELOW.

COMPANY _____

ADDRESS _____

PHONE _____ FAX _____

SERIAL NUMBER _____

DATE OF PURCHASE _____

DEALER NAME _____



CAUTION

The information in this manual is intended to guide the user in the use and application of this tool. It is not intended as a substitute for proper training and experience in safe work practices for this type of equipment.

Consult your supervisor or safety personnel if you have any questions regarding the safe operation of this tool.

TABLE OF CONTENTS

DISTRIBUTOR INFORMATION	2
REGISTRATION	3
TABLE OF CONTENTS	3
TOOL SPECIFICATIONS	
REL-2000MC	4
SAFETY INFORMATION AND WARNINGS	5-6
DAILY MAINTENANCE.....	7
OPERATING INSTRUCTIONS	7
MANUAL HYDRAULIC HANDLE PARTS LIST	8-9
FIXED HANDLE PART DRAWING #1	10
MOVABLE HANDLE PART DRAWING #2	11
 NOTE: FIXED HANDLE DWG #1 AND MOVABLE HANDLE DWG #2 PART #S WILL REMAIN CONSTANT FOR ALL MODELS, REFER TO HANDLE PARTS LIST ON PAGES 8 AND 9 FOR THESE ITEMS.	
 REL-2000MC	
REL-2000MC HEAD DRAWING #3	12
REL-2000MC HEAD PARTS LIST	13
LABELS.....	14
MAINTENANCE RECORDS.....	16
CONTACT INFORMATION	16



THIS SYMBOL INDICATES ITEMS OF EXTREME IMPORTANCE.
Safety of user and others may be in jeopardy if these instructions are not read and understood.

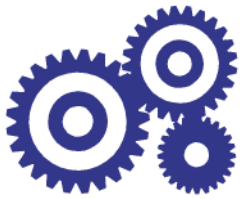

RELIABLE EQUIPMENT & SERVICE CO., INC.

REL-2000MC MANUAL HYDRAULIC CUTTING TOOL



Weight: 18 lbs.
Dimensions: 24" x 6" x 4"



REL-2000MC MANUAL HYDRAULIC CUTTING TOOL

This guillotine-type cutter will make a straight, clean cut every time. These cutters can be used for cutting a wide range of electrical conductors. The head opens easily for inserting cable at any location along the line.

Designed to cut copper, aluminum, ACSR, guy wire, soft steel bolts, rebar, ground and anchor rod.

Two-stage pumping piston for rapid advance, and twist handle release.

Magnetic oil reservoir plug traps metal contaminants.

The blades are manufactured from high strength special steel, heat treated to ensure a long service life.

The head can rotate by 360 degrees, enabling the operator to work in the most comfortable position, and can easily be opened to allow the cutting of running cables. REL-2000MC features an automatic safety valve to bypass oil when reaching maximum pressure; a pressure release device can also be operated at any stage of operation.

CAPACITY

CU & AL WIRE	2"
ACSR	2"
SOFT STEEL BOLTS	1-1/4"
WIRE ROPES	1"
REBAR	3/4"
GROUND & ANCHOR ROD	3/4"
STANDARD GUY WIRE*	3/4"
EHS GUY WIRE	5/8"



301 Ivyland Road • Warminster, PA 18974
Phone: 800-966-3530 • Fax: 215-357-9193
Visit us on the web at www.Reliable-Equip.com



WARNING

BEFORE USING THIS TOOL, READ THE WARNINGS and the recommended practices described in this manual. Failure by the operator to read and fully understand these warnings will leave this person unqualified to use and operate this tool. Property damage, severe personal injury, and/or death could result by not following these warnings.

These warnings will appear in appropriate locations when they are pertinent to the particular subject being shown. Read each one carefully and follow them strictly.



Eye Protection

WARNING

Always wear eye protection to avoid injury from flying debris or hydraulic oil leaks. Failure to do so can result in serious personal injury.



Dust Mask

WARNING

Always wear a dust mask. Failure to observe this warning may result in serious health issues and/or breathing difficulty.



Hard Hat

WARNING

Always wear a hard hat to avoid injury from falling debris. Failure to do so can result in serious personal injury.



Foot Protection

WARNING

Always wear foot protection. Failure to do so can result in serious personal injury.



Hearing Protection

WARNING

Always wear hearing protection, to avoid hearing loss due to long term exposure to high noise levels.



Protective Gloves

WARNING

Always wear protective gloves. Failure to do so can result in serious personal injury.



WARNING

Operation/Safety methods may vary in accordance with the working guidelines established by each utility or contractor.

For your own safety, ensure that you fully comply with all safe operation guidelines required by your employer.



WARNING

ELECTRICAL SHOCK HAZARD

Always wear and use the necessary clothing, equipment and safety practices to protect against electrical shock. Failure to follow these rules can result in serious personal injury or death.



GENERAL SAFETY



USE ALL APPROPRIATE AND APPLICABLE PERSONAL SAFETY EQUIPMENT as required by the operating company.

ALWAYS INSPECT TOOL for wear, damage, or deterioration every day.

Replace all parts that show signs of wear or damage.

INSPECT TOOL BEFORE USE. Replace any worn, damaged or missing parts. A damaged or improperly assembled tool may injure operator and/or nearby personnel.

KEEP ALL PARTS OF THE BODY AWAY from moving parts of the tool.

KEEP HANDS OUT FROM BETWEEN CUTTING BLADES AT THE TOOL HEAD.

ALL BODY PARTS SHOULD BE OUTSIDE DANGER ZONE PRIOR TO CUTTING.

MAKE SURE there is no person in close proximity to you or the tool who could be injured by any operation being performed, tool malfunction or flying debris.

DO NOT OVEREXTEND your position by overreaching or unbalancing the footing necessary to maintain physical control of your body and the tool.

ALWAYS MAINTAIN a firm grip on the tool to avoid loss of control during an operation, causing property damage, serious injury or death.

USE THIS TOOL FOR THE MANUFACTURERS' INTENDED PURPOSE ONLY.

OBSERVE CLOSELY ALL SAFETY RULES FOR A PARTICULAR JOB CLASS

**FAILURE TO HEED THESE WARNINGS COULD RESULT IN
PROPERTY DAMAGE, SERIOUS PERSONAL INJURY OR DEATH.**

DAILY MAINTENANCE

The life, reliability, and safety of the tool is dependent on proper maintenance. Clean and inspect all surfaces including head, latch mechanism, blade, ram, body and handles.

WARNING blade, head and handles may cut or pinch. Please use extreme caution.

Worn or damaged parts (i.e. chipped or cracked blade) may malfunction during operation, causing more extensive damage to the tool and/or severe injury to the operator or bystander..

All parts must be replaced with new parts if signs of wear or damage are evident.

OPERATION

Read entire manual prior to using this tool.

(Refer to all safety recommendations and warnings)

Observe all safety precautions and procedures required by the operating company. Also refer to SAFETY information found on pages 5 and 6)

1. Before cutting, ensure that subject is within the capacity listed for the tool. (see page 4)



WARNING

Do not cut live conductors.

Hardened metals may fly when severed.

Take necessary precautions. wear safety glasses.

Keep all body parts away from cutting blades and moving parts.

Failure to follow these rules can result in serious personal injury or death.

2. Retract blade completely . (Open pump handles completely and rotate handle 45° and hold while ram retracts completely.)

3. Open cutter by removing locking pin.

4. Place tool around connector or material to be cut.

5. Close and secure cutter head using locking pin.

NOTE: Failure to secure head may result in severe tool damage and/or personal injury.

6. Advance blade to subject with fast advance feature on handle.

The material **MUST** be cut at a 90° angle to ensure a proper cut with minimal distortion.

NOTE: Tool head rotates to aid in proper alignment.



WARNING: Failure to cut subject at the proper 90° angle may result in severe tool damage and/or personal injury.

8. Pump handle to advance cutting blade, *Check alignment*, continue until cut is complete.

9. To release blade open pump handles completely and rotate handle 45° and hold while ram retracts completely.

MANUAL HYDRAULIC HANDLE PARTS LIST

ITEM	QTY	PART NO	DESCRIPTION	DRAWING #
1	1	R51014	BODY, 2 IN CUTTER	2
7	1	R18007	RETURN SPRING	2
8	1	R18008	CAP, SPRING	2
9	1	R18009	SNAP RING, CAP STOP	2
10	1	R18010	REAR STOP	1
12	2	R18012	HARD BALL, 7/32 DIA.	1, 2
13	2	*R18013	O'RING	1, 2
14	2	*R18014	BU RING	1, 2
15	1	R18015	RELEASE PLUNGER	2
16	1	R18016	SPRING, RELEASE	1
17	1	R18017	BRASS NUT	2
18	1	R18018	SIDE PLUG	2
19	1	R18019	PINTLE, SIDE PLUG	2
20	1	R18020	CHECK CAP	1
21	1	R18021	BALL, 3/16, FEED CHK.	1
22	1	R18022	FILTER BODY	1
23	1	R18023	SCREEN, BRASS	1
24	1	R18024	FINGER CLIP	1
25	1	R18025	MOUNT, BODY HANDLE	1
26	1	R18026	RESERVOIR PLUG ASSY, R410-55	1
27	1	R18027	MAGNET, ASSY R410-55	1
28	1	R-510-30	HANDLE, FIBERGLASS BODY	1
29	1	R18029	PUMP ARM, FIBERGLASS, 410-30	2
30	1	R18030	SHOULDER HOUSING	2
31	1	R18031	POINTER	2
32	1	R18032	RELEASE FINGER	2
33	4	R18033	BRONZE BUSHINGS	2
34	1	R18034	KNUCKLE	2
35	1	R18035	FAST ADV. PLUG	1
36	1	R18046	SET SCREW, 8-32 X 1/8	2
37	1	R18037	3/32 BALL	2
38	1	R18038	LOWER CHK. SPRG.	1
39	2	R18039	UPPER CHK SPRG.	1
40	1	R28540	PISTON INJECTOR	2

MANUAL HYDRAULIC HANDLE PARTS LIST

ITEM	QTY	PART NO	DESCRIPTION	DWG #
41	1	*R28014	WIPER	2
42	1	*R28015	O'RING, LO PR PISTON	2
43	1	*R18043	O'RING, HI PRESS PISTON	2
48	1	R18048	BALL, 1/4	1
49	1	R18049	PIVOT PIN, SHOULDER	2
50	1	R18050	TORSION SPRING	2
51	2	R18051	9/32 BALL	1
54	1	R19054	GRIP, PUMP ARM, R410-31	2
55	1	R19055	GRIP, HANDLE, R510-31	1
56	2	R18056	SNAP RINGS, C31	2
57	2	R18057	3/16 X 1 3/8 ROLL PIN	2
60	1	R18200	PRESET PRES . RELIEF	2
61	1	R-2000-1	RESERVOIR	1
63	2	R18077	SPRING	1, 2
66	1	*R18078	O' RING	1, 2
68	1	R18080	SPRING	2
75	1	R410-57	COVER, HANDLE HEAD, R410-57	2
80	1	*R18013	O'RING, SIDE PLUG	2
82	1	R18059	10-32 X 3/8 SHCS	2
83	1	*R18058	O'RING	1, 2
84	1	*R18089	O'RING	2
89	1	R-510A-27	RUBBER COVER, BODY	1
90	1	R510-31	RUBBER MOUNT COVER	1
91	1	REL-HTB-2000	HYDRAULIC TOOL BAG FOR REL-2000MC	1

SEAL KIT INCLUDES PARTS MARKED *

Complete disassembly is not recommended. Return the unit to an authorized dealer for total disassembly and/or repair.

All maintenance or disassembly should take place on a flat, clean work surface covered with towels or wipers so as to have a clean space for the disassembled parts.

Inspect each part during disassembly for wear, scratches, and cuts. Discard the worn or damaged parts and replace with new factory authorized parts.

O-rings are sensitive to sharp edges. Inspect closely for cuts or damage. A small cut will cause a leak. When assembling or disassembling O-rings, use hydraulic fluid as a lubricant to help disassembly or installation.

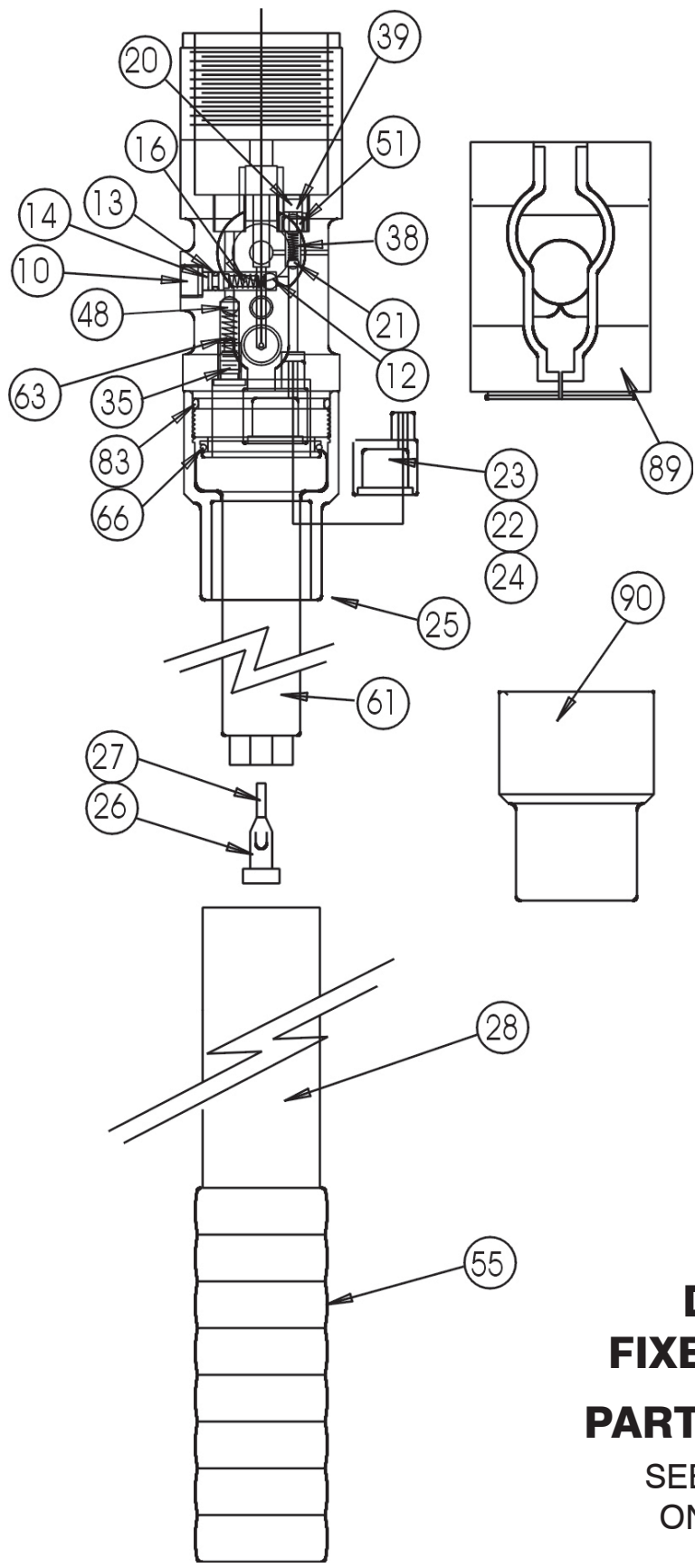

DWG #1
FIXED HANDLE
PARTS DRAWING
 SEE PARTS LIST
 ON PAGES 8-9

DWG #2 MOVABLE HANDLE PARTS DRAWING

SEE PARTS LIST
ON PAGES 8-9

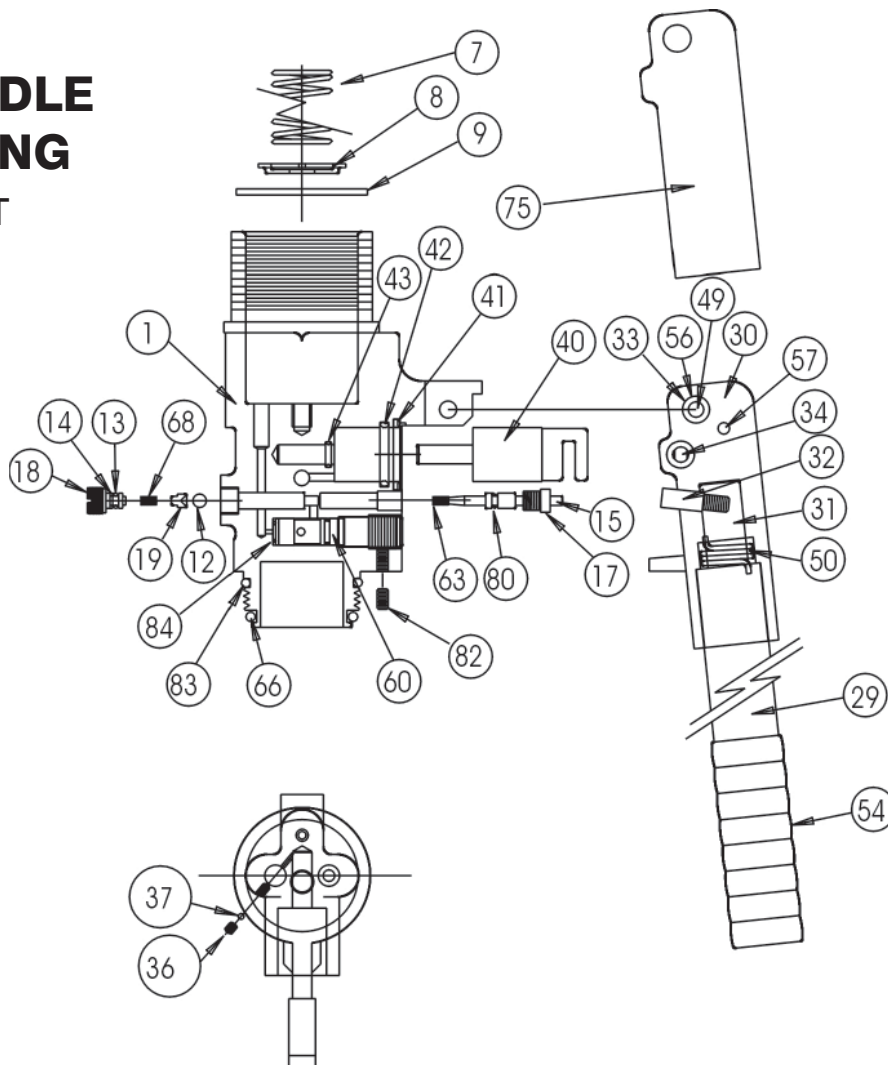

WARNING

BEFORE USING THIS PRODUCT READ THE SAFETY WARNINGS and recommended practices described in the manual. Failure by the operator to read and fully understand the warnings will leave this person unqualified to use and operate the tool.

Failure to observe all warnings and instructions could result in property damage, severe personal injury, and/or death.

RELIABLE EQUIPMENT & SERVICE CO., INC.

92 Steamwhistle Drive • Ivyland, PA 18974 • USA
Phone: 215-357-3500 • Fax: 215-357-9193

MODEL: _____

MAX. PRESSURE: _____

SERIAL NO.: _____

YEAR: _____



CAUTION

Operation and safety methods may vary in accordance with the guidelines established by each utility. For your safety, ensure that you fully comply with all safe operation guidelines established by your respective power utility.

REL-SM

DANGER

The user should be properly trained in the correct procedures required for work on or around electrical lines.



DANGER
RAM
CLOSES

NOTE: Keep Label Set clean and legible. Replace decals when necessary. Part #RL19400

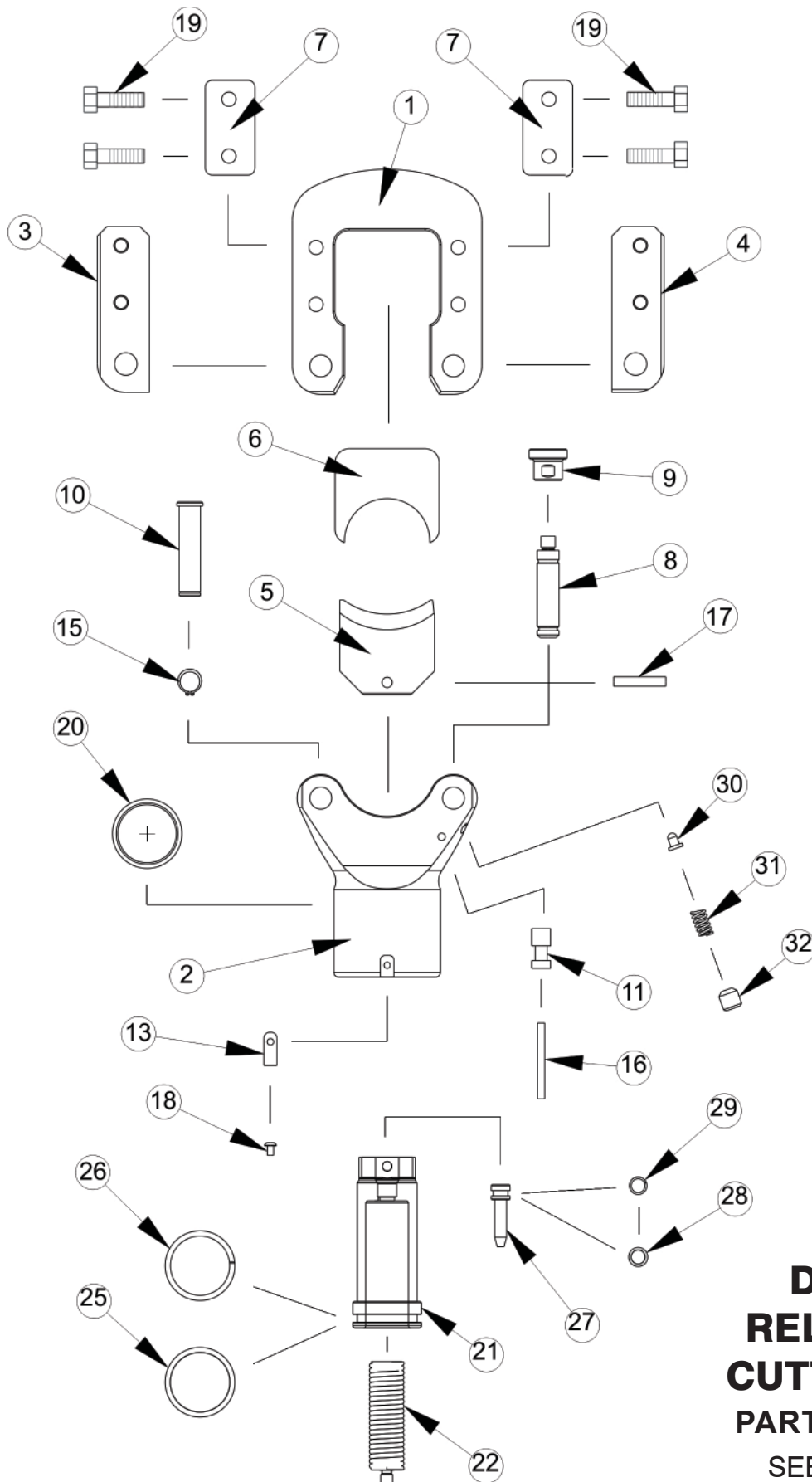

DWG #3
REL-2000MC
CUTTER HEAD
PARTS DRAWING
 SEE PAGE #15

REL-2000MC HEAD PARTS LIST

ITEM	PART NO	QTY	DESCRIPTION	DRAWING #
1	R51001	1	SUPPORT	3
2	R51002	1	YOKE	3
3	R51003	1	LEFT GUIDE	3
4	R51004	1	RIGHT GUIDE	3
5	R51005	1	LOWER BLADE	3
6	R51006	1	UPPER BLADE	3
7	R51007	2	BACK PLATE	3
8	R51008	1	KNOB PIN	3
9	R51009	1	KNOB	3
10	R51010	1	HINGE PIN	3
11	R51011	1	GUIDE PIN	3
13	R51013	1	STOP TAB	3
15	R51015	1	RETAINING RING, HINGE PIN	3
16	R51016	1	COIL PIN, GUIDE PIN	3
17	R51017	1	COIL PIN, LOWER BLADE	3
18	R51018	1	SCREW, STOP TAB	3
19	R51019	4	SCREW, LEFT & RIGHT GUIDES	3
20	R28004	1	WIPER, RAM	3
21	R51012A	1	RAM ASSEMBLY	3
22	R51022	1	RETURN SPRING ASSY	3
24	R51024	4	LOCKWASHER	3
25	R12813	1	* O-RING , RAM	3
26	R12812	1	* B/U RING, RAM	3
27	R28010	1	BOLT, SPRING SEAL	3
28	R28011	1	* O-RING, SEAL BOLT	3
29	R28012	1	* B/U RING, SEAL BOLT	3
30	R41008	1	DETENT	3
31	R41009	1	SPRING, DETENT	3
32	R32125	1	SET SCREW X 3/16 LONG, DETENT	3

SEAL KIT INCLUDES ALL PARTS MARKED *

Contact RELIABLE EQUIPMENT at 800-966-3530 if you have any questions related to the instructional information found in this manual.

Maintenance Records

Date	Parts or Service Required

If you have any questions regarding the information found in this manual please contact RELIABLE EQUIPMENT at the address, phone or fax numbers shown below.



**RELIABLE EQUIPMENT
& SERVICE CO., INC.**

301 Ivyland Road • Warminster, PA 18974
Phone: 800-966-3530 • Fax: 215-357-9193
Visit us on the web at www.Reliable-Equip.com