

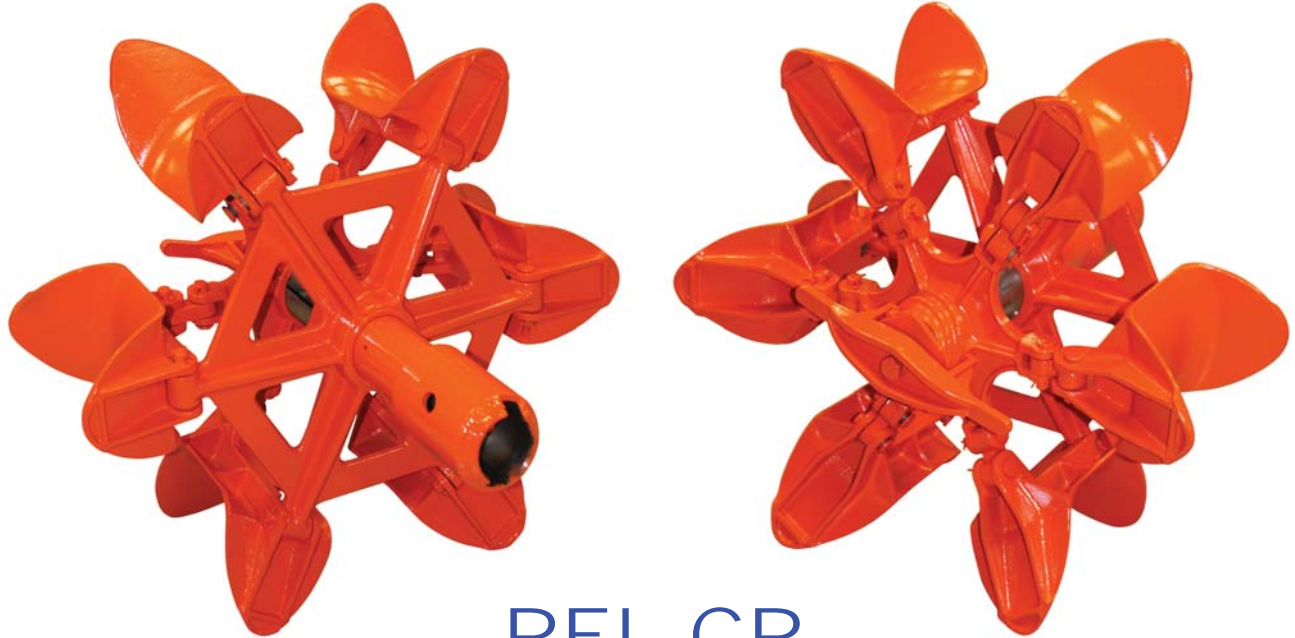

# RELIABLE EQUIPMENT & SERVICE CO., INC.



## REL-CR Collapsible Reel

### REL-CR - Collapsible Reel

The **REL-CR** reel may be used in take-up and stringing applications requiring up to 4,000 pounds of pulling force.

Up to 1,600 feet of 1/4" wire rope or cable may be coiled onto the reel. (Max. storage 200 lbs.)

A half turn of the handle collapses the outer rim. The six rim segments pivot inward when the sliding spider is released allowing quick removal of wire or cable spool.

Set the reel by lifting the rim segment while turning handle into the spindle.



The reel mounts onto any 2-7/16" bayonet or pin type winch drum shaft.

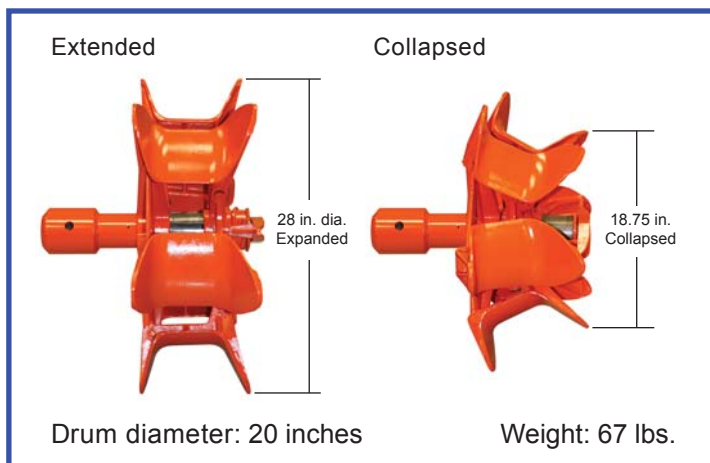

 **RELIABLE EQUIPMENT  
& SERVICE CO., INC.**

301 Ivyland Road • Warminster, PA 18974  
Phone: 800-966-3530 • Fax: 215-357-9193  
Visit us on the web at [www.Reliable-Equip.com](http://www.Reliable-Equip.com)

# REL-CR

## REPAIR PARTS & ASSEMBLIES

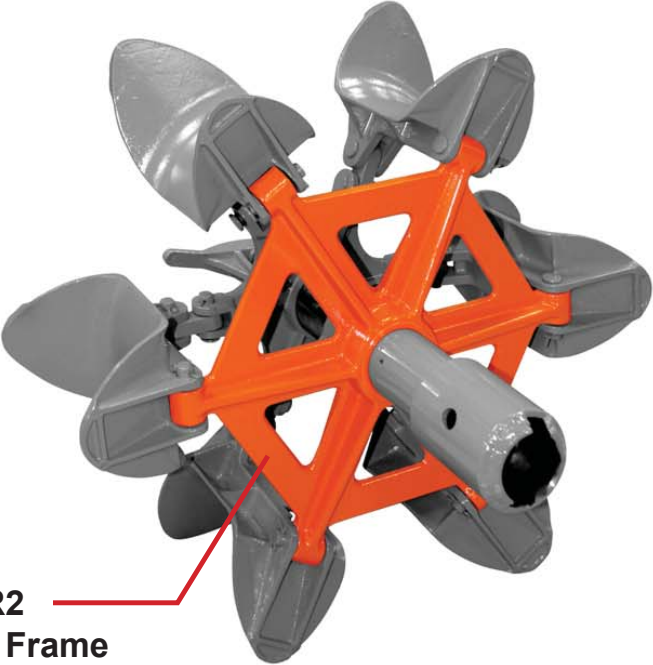

**R-CR2**  
Rear Frame

**R-CR1A**  
Cradle / Guide  
2" Pin  
2-7/8" Pin  
Cotter Pin (x2)



**R-CR6**  
Front Frame  
Moving Spider

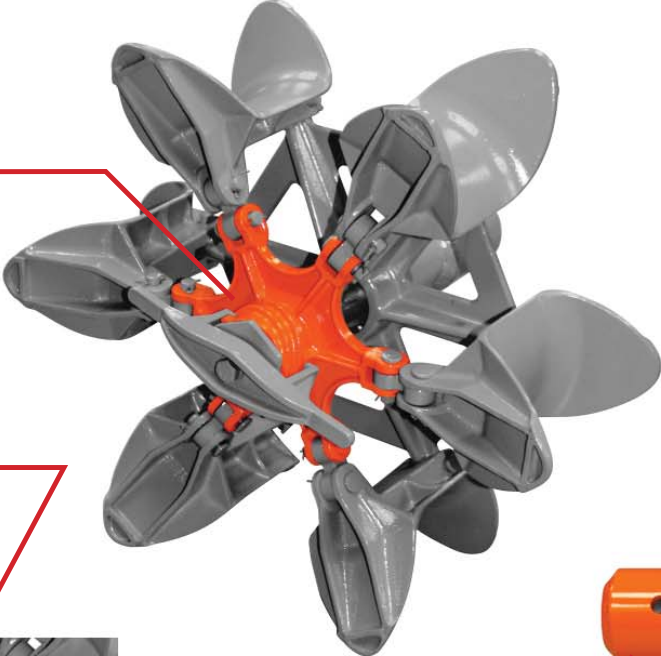

**R-CR4**  
Handle  
**R-CR4A**  
Handle  
& Plug Assy.

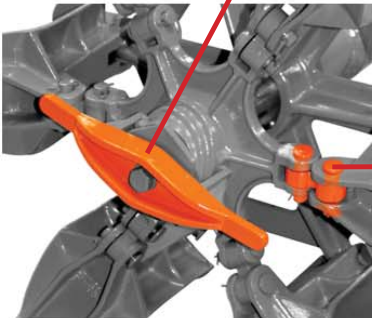

**R-CR3A**  
2" Pin  
Link  
Cotter Pin

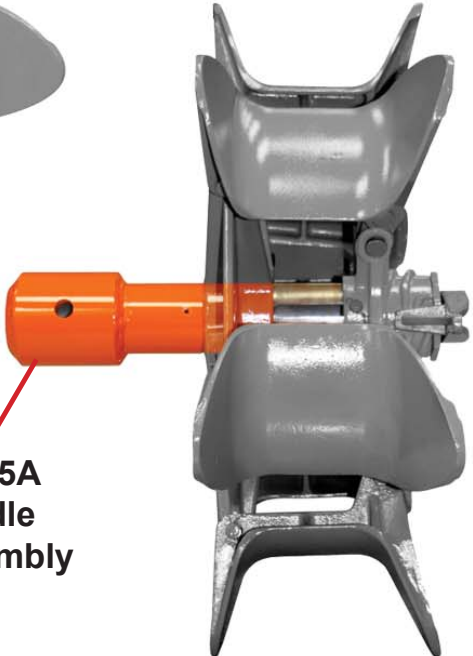

**R-CR5A**  
Spindle  
Assembly